

Operating instruction

FLUXUS WD

UMFLUXUS_WDV1-5EN

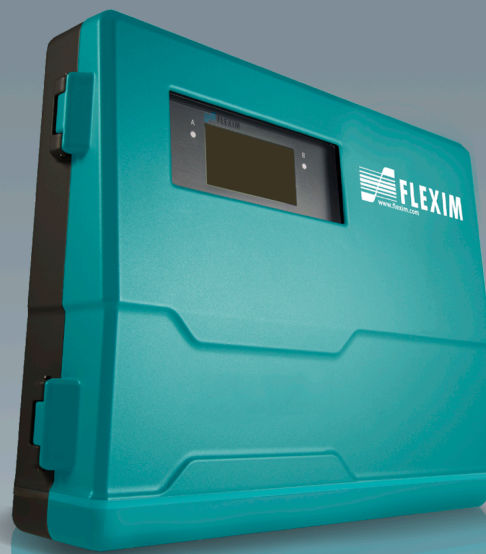

FLUXUS is a registered trademark of FLEXIM GmbH.

FLEXIM GmbH
Boxberger Straße 4
12681 Berlin
Germany

Tel.: +49 (30) 936 67 660
Fax: +49 (30) 936 67 680
E-mail: info@flexim.com
www.flexim.com

Operating instruction for
FLUXUS WD
UMFLUXUS_WDV1-5EN, 2020-03-31
Article number: 21449
Copyright (©) FLEXIM GmbH 2020
Subject to change without prior notice.

Table of contents

1	Introduction	7
2	Safety instructions	8
2.1	General safety instructions	8
2.2	Intended use	8
2.3	Not intended use	9
2.4	Safety instructions for the user	9
2.5	Safety instructions for the operator	9
2.6	Safety instructions for electrical work	9
2.7	Safety instructions for transport	10
2.8	Recommended procedure in hazardous situations	10
3	General principles	11
3.1	Measurement principle	11
3.2	Measurement arrangements	14
3.3	Acoustic penetration	16
3.4	Undisturbed flow profile	17
4	Product description	19
4.1	Measuring system	19
4.2	Handling concept	19
4.3	Display	21
4.4	Keyboard	22
5	Transport and storage	23
5.1	Transport	23
5.2	Storage	23
6	Mounting	24
6.1	Transmitter	24
6.2	Transducers	29
7	Connection	52
7.1	Transducers	53
7.2	Power supply	61
7.3	Outputs	63
7.4	Inputs	65
7.5	Service interfaces	67
8	Start-up	70
8.1	Start-up settings	71
8.2	Switching on	71
8.3	Status indications	72
8.4	Program branches	73
8.5	Language	73
8.6	Initialization	73
8.7	Date and time	74
8.8	Information regarding the transmitter	74

9	Measurement	75
9.1	Parameter input	75
9.2	Measurement settings	79
9.3	Start of the measurement	89
9.4	Display of measured values	92
9.5	Display of parameters	95
9.6	Repeated display of measured values	96
9.7	Execution of special functions	96
9.8	Stop of the measurement	97
10	Troubleshooting	98
10.1	Problems with the measurement	99
10.2	Measuring point selection	99
10.3	Maximum acoustic contact	99
10.4	Application-specific problems	100
10.5	Significant deviations of the measured values	100
10.6	Problems with the totalizers	100
11	Maintenance and cleaning	101
11.1	Maintenance	102
11.2	Cleaning	102
11.3	Calibration	102
11.4	Firmware update	102
12	Dismounting and disposal	103
12.1	Dismounting	103
12.2	Disposal	103
13	User modes	104
13.1	StandardUser mode	105
13.2	ExpertUser mode	110
13.3	SuperUser mode and SuperUser ext. mode	113
14	Outputs	117
14.1	Configuration of a binary output	117
14.2	Activation of a binary output as pulse output	120
15	Inputs (optional)	121
15.1	Configuration of an input	121
15.2	Assignment of an input	124
16	Data logger	125
16.1	Configuration of the data logger	125
16.2	Deletion of the data logger	129
16.3	Information regarding the data logger	129
16.4	Print of measured values	130
16.5	Transmission settings	130
17	Data transmission	131
17.1	Service interfaces	131
17.2	Process interface	132

18	Advanced functions	133
18.1	Totalizers	133
18.2	FastFood mode	135
18.3	Calculation channels	136
18.4	Diagnosis with the help of the snap function	141
18.5	Modification of the limit for the inner pipe diameter	142
18.6	Remote functions	143
18.7	Event trigger	145
18.8	Event protocol	150
19	Settings	151
19.1	Dialogs and menus	151
19.2	Measuring modes	153
19.3	Measurement settings	153
19.4	Units of measurement	154
19.5	Material scroll list	154
19.6	Working with parameter records	155
19.7	Contrast settings	156
19.8	HotCodes	156
19.9	Key lock	157

Annex

A	Menu structure	159
B	Units of measurement	174
C	Reference	177
D	Conformity declarations	180



1 Introduction

This operating instruction has been written for users operating the ultrasonic flowmeter FLUXUS. It contains important information about the measuring equipment, how to handle it correctly, and how to avoid damages. Read the safety instructions carefully. Make sure you have read and understood this operating instruction before using the measuring equipment.

Any work on the measuring equipment has to be carried out by authorized and qualified personnel in order to detect and avoid possible risks and dangers.

Presentation of warnings

This operating instruction contains warnings marked as follows:

Danger!	
	<p>Type and source of danger danger with high level of risk, which if not avoided, can lead to death or serious injuries → measures of prevention</p>
Warning!	
	<p>Type and source of danger danger with medium level of risk, which if not avoided, can lead to serious or moderate injuries → measures of prevention</p>
Caution!	
	<p>Type and source of danger danger with low level of risk, which if not avoided, can lead to moderate or minor injuries → measures of prevention</p>
Important!	
This text contains important information which should be observed to avoid material damage.	
Notice!	
This text contains important information about the handling of the measuring equipment.	

Storage of the operating instruction

The operating instruction must permanently be available at the place where the measuring equipment is used. It must always be available to the user.

User comments

All reasonable effort has been made to ensure the correctness of the content of this operating instruction. If you, however, find some erroneous information or miss information, please inform us.

We will be grateful for any suggestions and comments regarding the concept and your experience working with the measuring equipment. If you have any suggestions about improving the documentation and particularly this operating instruction, please let us know so that we can consider your comments for future reprints.

Copyright

The contents of this operating instruction are subject to changes without prior notice. All rights reserved. No part of this operating instruction may be reproduced in any form without FLEXIM's written permission.

2 Safety instructions







2.1 General safety instructions

Prior to any work, read the operating instruction carefully and in full.

Failure to comply with the instructions, in particular with the safety instructions, poses a risk to health and can lead to material damages. For further information, contact FLEXIM.

During installation and operation of the measuring equipment, observe the ambient and installation conditions specified in the documentation.

Explanation of symbols on the transmitter:

symbol	explanation
	direct current
	connection to ground
	ground conductor terminal
	warning of voltage
	observe the operating instruction
	Attention!

The measuring equipment has to be checked for proper condition and operational safety before each use. If troubles or damages have occurred during installation or operation of the measuring equipment, please inform FLEXIM.

It is not allowed to make unauthorized modifications or alterations to the measuring equipment.

If the measuring point is within an explosive atmosphere, the danger zone and present explosive atmosphere have to be determined. The transmitter, transducers and accessories have to be appropriate and approved for the conditions within the corresponding zone.

The personnel has to be suitably trained and experienced for the work.

Observe the "Safety instructions for the use in explosive atmospheres", see document SIFLUXUS. Observe the instructions for hazardous substances and the respective safety data sheets. Observe the regulations for the disposal of electrical equipment.

2.2 Intended use

The measuring equipment is intended for the measurement of fluid properties in closed pipes. By means of connected transducers, the transit times of the ultrasonic signals in the fluid and the pipe are measured and evaluated.

The transmitter uses these values to calculate the sought quantities, e.g., volumetric flow rate and mass flow rate.

Through comparison with the values stored in the transmitter further physical quantities can be determined. The physical quantities are provided via configurable outputs and the display.

- All instructions of this operating instruction have to be observed to ensure intended use.
- Any use beyond or other than the intended use is not covered by warranty and can present a danger. Any damage arising from not intended use shall be solely the liability of the operator or user.
- The measurement is carried out without direct contact to the fluid in the pipe. The flow profile is not influenced.
- The transducers are fixed to the pipe using the supplied transducer mounting fixture.
- If an extension cable is required to connect the transducers to the transmitter, a junction box can be used (optional). Observe the safety instructions in the operating instruction. For the technical data of the junction box, see technical specification.
- Observe the operating conditions, e.g., environment, voltage ranges. For the technical data of the transmitter, transducers and accessories, see technical specification.

2.3 Not intended use

Not intended use in terms of a misuse means:

- any work on the measuring equipment without observing all instructions in this operating instruction
- use of transmitter, transducer and accessory combinations not intended by FLEXIM
- installation of the transmitter, transducers and accessories in explosive atmospheres they are not approved for
- any work on the measuring equipment (e.g., installation, dismantling, connection, start-up, operation, service and maintenance) carried out by unauthorized and untrained personnel
- storage, installation and operation of the measuring equipment outside the specified ambient conditions (see technical specification)

2.4 Safety instructions for the user

Any work on the transmitter has to be carried out by authorized and qualified personnel. Observe the safety instructions in the operating instruction. For the technical data of the transmitter, transducers and accessories, see technical specification.

- Observe the safety and accident prevention regulations applicable on the site of operation.
- Only use the supplied mounting fixtures and transducers as well as the intended accessories.
- Always wear the required personal protective equipment.

2.5 Safety instructions for the operator

- The operator shall qualify the personnel to perform their assigned tasks. The operator shall provide the required personal protective equipment and oblige the personnel to wear it. It is recommended to risk assess the workplace.
- Besides the safety instructions in this operating instruction, the health, safety and environment regulations applicable for the range of application of the transmitter, transducers and accessories have to be observed.
- With the exceptions stated in chapter 11, the measuring equipment is maintenance-free. Any components and spare parts may only be replaced by FLEXIM. The operator shall carry out periodic checks for changes or damages that can present a danger. For further information, contact FLEXIM.
- Observe the specifications for the installation and connection of the transmitter, transducers and accessories.

2.6 Safety instructions for electrical work

- Prior to any work on the transmitter (e.g., installation, dismantling, connection, service and maintenance), the transmitter has to be disconnected from the power supply. It is not sufficient to remove the internal fuse of the instrument.
- Electrical work may only be carried out if there is enough space.
- Open the transmitter in safe ambient conditions only (e.g., air humidity < 90 %, no conductive pollution, no explosive atmosphere). Otherwise, additional protective measures have to be taken.
- The degree of protection of the transmitter is only ensured if all cables are tightly fitted using cable glands and the housing is firmly screwed.
- The condition and tight fit of the electrical connections have to be checked at regular intervals.
- When connecting the transmitter to the power supply, an appropriate equipment switch according to IEC 60947-1 and IEC 60947-3 has to be installed as disconnecting device. The equipment switch has to disconnect all live wires. The ground conductor connection must not be interrupted. The equipment switch has to be easily accessible and clearly marked as a disconnecting device for the transmitter. It should be located near the transmitter. If the transmitter is used in an explosive atmosphere, the equipment switch has to be installed outside the explosive atmosphere. If this is not possible, it has to be installed in the least hazardous area.
- The connection may only be made to networks up to overvoltage category II. When connecting the inputs and outputs as well as the power supply, observe the installation instructions, in particular the terminal assignment (see chapter 7).
- The front plate must not be removed. The transmitter does not contain any components to be maintained by the user. For repair and service work, please contact FLEXIM.
- Observe the safety and accident prevention regulations for electrical systems and equipment.

Fig. 2.1: Transmitter

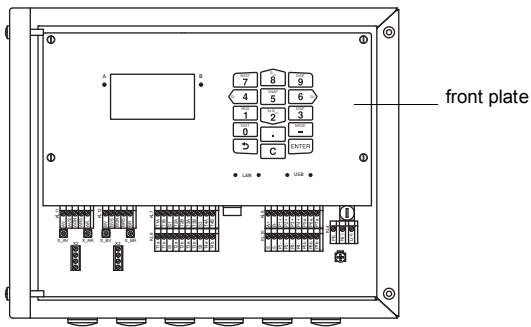

2.7 Safety instructions for transport

Caution!



Warning of injuries due to falling objects

- Unsecured and falling objects can lead to severe injuries.
- Secure all components against falling during transport.
 - Wear the required personal protective equipment.
 - Observe the applicable rules.

- If you detect a transport damage when unpacking the delivery, please contact the supplier or FLEXIM immediately.
- The transmitter is a sensitive electronic measuring instrument. Avoid shocks or impacts.
- Handle the transducer cable with care. Avoid excessive bending or buckling. Observe the ambient conditions.
- Select a solid surface to put the transmitter, transducers and accessories on.
- The transmitter, transducers and accessories have to be properly packed for transport:
 - Use, if possible, the original packaging by FLEXIM or an equivalent cardboard box.
 - Position the transmitter, transducers and accessories in the middle of the cardboard box.
 - Fill any voids with appropriate packaging material (e.g., paper, foam, bubble wrap).
 - Protect the cardboard box against humidity.

2.8 Recommended procedure in hazardous situations

Fire fighting measures

- If possible, disconnect the transmitter from the power supply.
- Prior to extinguishing, protect any electrical parts that are not affected by the fire (e.g., using a cover).
- Select a suitable extinguishing agent. Avoid, if possible, conductive extinguishing agents.
- Observe the applicable minimum distances. The minimum distances differ depending on the used extinguishing agent.

3 General principles

In the ultrasonic flow measurement, the flow velocity of the fluid in a pipe is determined. Further physical quantities are derived from the flow velocity and from additional physical quantities, if necessary.

3.1 Measurement principle

The flow velocity of the fluid is measured in the TransitTime mode using the ultrasonic-transit time difference correlation principle. When measuring with a high proportion of gas or solid particles, the transmitter can toggle into the NoiseTrek mode.

3.1.1 Terms

Flow profile

Distribution of flow velocities over the cross-sectional pipe area. For an optimal measurement, the flow profile has to be fully developed and axisymmetrical. The shape of the flow profile depends on whether the flow is laminar or turbulent and is influenced by the conditions at the inlet of the measuring point.

Reynolds number Re

Coefficient describing the turbulence behavior of a fluid in the pipe. The Reynolds number Re is calculated from the flow velocity, the kinematic viscosity of the fluid and the inner pipe diameter.

If the Reynolds number exceeds a critical value (usually approx. 2300, if the fluid flows in a pipe), a transition from a laminar flow to a turbulent flow takes place.

Laminar flow

A flow without any turbulence. There is no mixing between the parallel flowing layers of the fluid.

Turbulent flow

A flow with turbulences (swirling of the fluid). In technical applications, the flow in the pipe is mostly turbulent.

Transition range

The flow is partly laminar and partly turbulent.

Sound speed c

Speed of the propagating sound. The sound speed depends on the mechanical properties of the fluid or the pipe material. In pipe materials and other solid materials, a distinction is made between the longitudinal and transversal sound speed.

Flow velocity v

Average value of all flow velocities of the fluid over the cross-sectional pipe area.

Acoustic calibration factor k_a

$$k_a = \frac{c_\alpha}{\sin \alpha}$$

The acoustic calibration factor k_a is a transducer parameter which results from the sound speed c within the transducer and the angle of incidence. According to Snell's law of refraction, the angle of propagation in the adjoining fluid or pipe material is:

$$k_a = \frac{c_\alpha}{\sin \alpha} = \frac{c_\beta}{\sin \beta} = \frac{c_\gamma}{\sin \gamma}$$

Fluid mechanics calibration factor k_{Re}

With the fluid mechanics calibration factor k_{Re} , the measured value of the flow velocity in the area of the sound beam is converted into the value of the flow velocity across the whole cross-sectional pipe area. In case of a fully developed flow profile, the fluid mechanics calibration factor only depends on the Reynolds number and the roughness of the inner pipe wall. The fluid mechanics calibration factor is recalculated by the transmitter for each new measurement.

Volumetric flow rate \dot{V}

$$\dot{V} = v \cdot A$$

The volume of the fluid that passes through the pipe per unit time. The volumetric flow rate is calculated from the product of the flow velocity v and the cross-sectional pipe area A .

Mass flow rate \dot{m}

$$\dot{m} = \dot{V} \cdot \rho$$

3.1.2 Measurement of the flow velocity in the TransitTime mode

The mass of the fluid that passes through the pipe per unit time. The mass flow rate is calculated from the product of the volumetric flow rate \dot{V} and the density ρ .

The signals are emitted and received by two transducers alternatively in and against the flow direction. If the fluid is flowing, the signals propagating in the fluid are displaced with the flow.

Caused by this displacement, the sound path of the signal is reduced in flow direction and increased in the opposite direction.

This causes a change in the transit times. The transit time of the signal in flow direction is shorter than the transit time against the flow direction. The transit time difference is proportional to the average flow velocity.

The average flow velocity of the fluid is calculated as follows:

$$v = k_{Re} \cdot k_a \cdot \frac{\Delta t}{2 \cdot t_y}$$

where

- v – average flow velocity of the fluid
- k_{Re} – fluid mechanics calibration factor
- k_a – acoustic calibration factor
- Δt – transit time difference
- t_y – transit time in the fluid

Fig. 3.1: Sound path of the signal in the flow direction

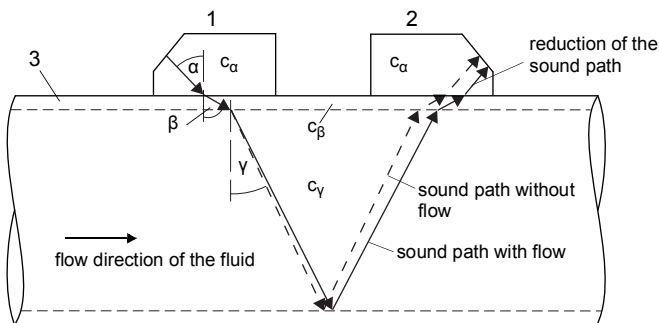

- c – sound speed
- 1 – transducer (emitter)
- 2 – transducer (receiver)
- 3 – pipe wall

Fig. 3.2: Sound path of the signal against the flow direction

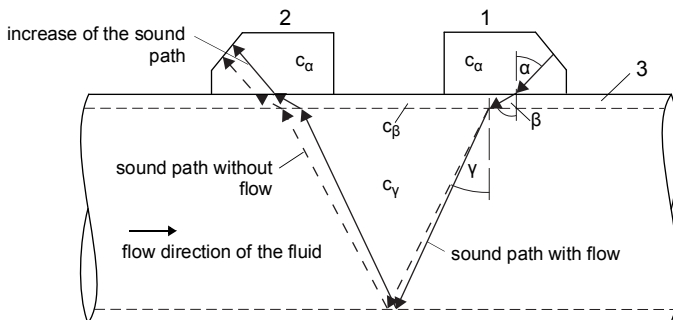

- c – sound speed
- 1 – transducer (emitter)
- 2 – transducer (receiver)
- 3 – pipe wall

Fig. 3.3: Transit time difference Δt

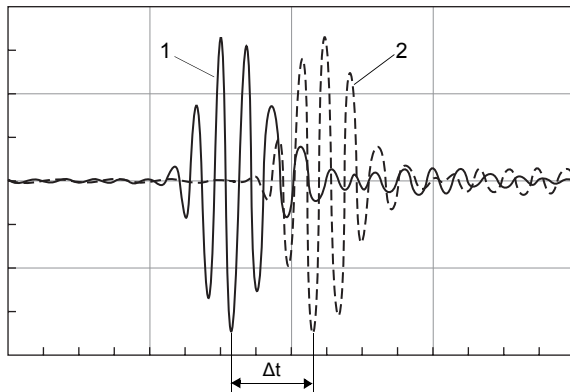

- 1 – signal in the flow direction
- 2 – signal against the flow direction

3.1.3 Measurement of the flow velocity in the NoiseTrek mode

If the proportion of gas and/or solid particles in the fluid is high, the damping of the ultrasonic signal can be so high that the complete propagation of the fluid and therefore a measurement in TransitTime mode is not possible anymore. In this case the NoiseTrek mode has to be used.

The NoiseTrek mode uses the presence of gas bubbles and/or solid particles in the fluid.

Ultrasonic signals are sent from a transducer into the fluid at short intervals, reflected by the gas bubbles and/or the solids particles and again received by the same transducer.

The measurement arrangement used in the TransitTime mode does not need to be changed.

The transit time difference Δt of 2 consecutive ultrasonic signals is determined. It behaves proportionately to the distance the gas bubble/solid particle is covering between 2 consecutive pulses and thus, to the average flow velocity of the fluid.

Fig. 3.4: Measurement of the flow velocity in the NoiseTrek mode

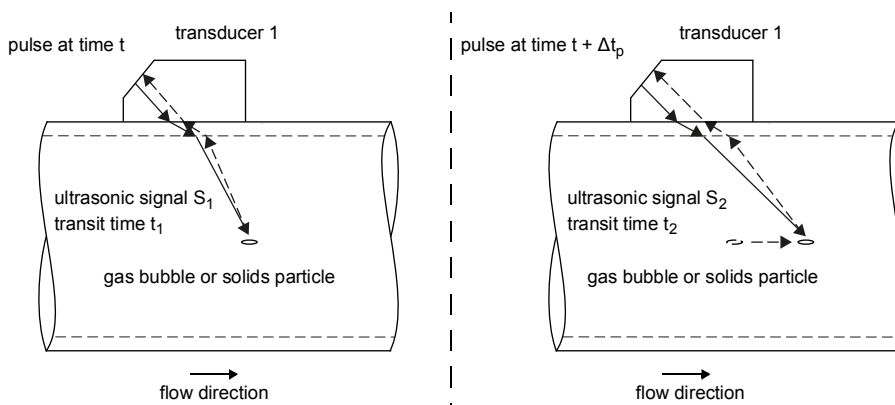

The average flow velocity of the fluid is calculated as follows:

$$v = k_{Re} \cdot k_a \cdot \frac{\Delta t}{2 \cdot \Delta t_p}$$

where

- v – average flow velocity of the fluid
- k_{Re} – fluid mechanics calibration factor
- k_a – acoustic calibration factor
- Δt_p – time difference between 2 consecutive pulses
- Δt – transit time difference of ultrasonic signals S_1 and S_2 ($\Delta t = t_2 - t_1$)

Depending on the attenuation of the ultrasonic signal, the error of measurement in the NoiseTrek mode can be greater than in the TransitTime mode.

3.1.4 Measurement of the flow velocity in the HybridTrek mode

The HybridTrek mode combines the TransitTime and the NoiseTrek mode. During a measurement in the HybridTrek mode, the transmitter automatically toggles between the TransitTime and the NoiseTrek mode depending on the gaseous or solid content.

The measurement arrangement is identical to the one in the TransitTime mode.

3.2 Measurement arrangements

3.2.1 Terms

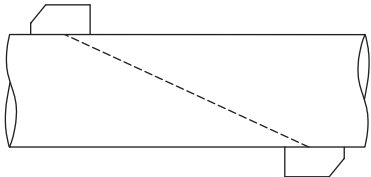
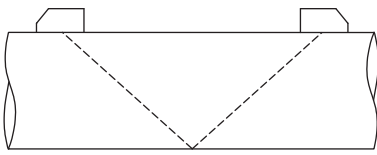
diagonal arrangement	reflection arrangement
The transducers are mounted on opposite sides of the pipe.	The transducers are mounted on the same side of the pipe.
	

Sound path

The distance covered by the ultrasonic signal after crossing the pipe once. The number of the sound paths is:

- odd if the measurement is carried out in diagonal arrangement
- even if the measurement is carried out in reflection arrangement

Beam

The path covered by the ultrasonic signal between the transducers, i.e., the transducer emitting the ultrasonic signal and the transducer receiving it. One beam consists of 1 or several sound paths.

Fig. 3.5: Diagonal arrangement with 2 beams and 3 sound paths

Fig. 3.6: Reflection arrangement with 1 beam and 4 sound paths

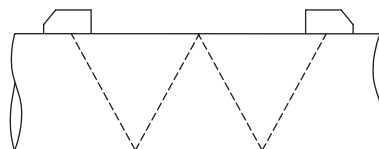
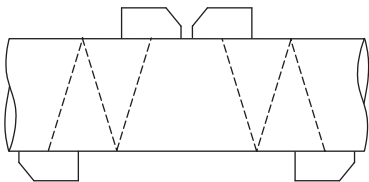

Transducer distance

The transducer distance is measured between the inner edges of the transducers.

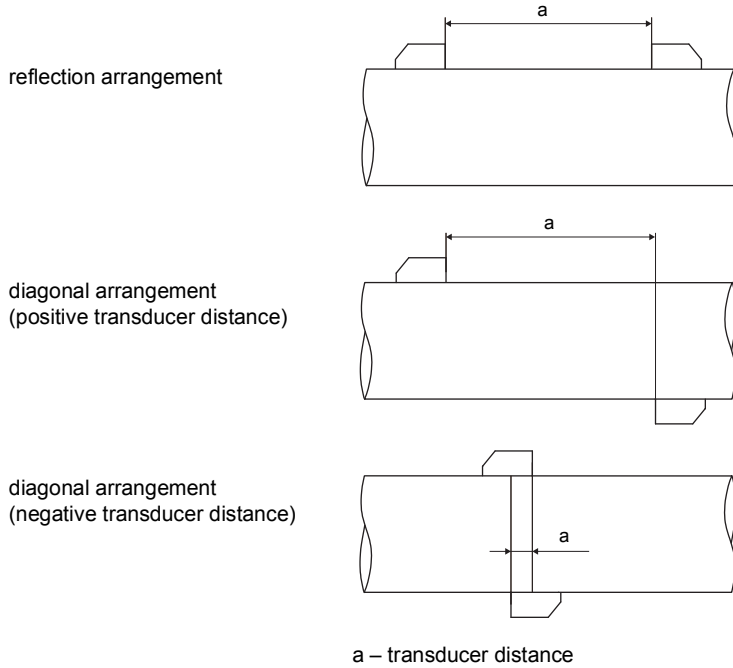

Sound beam plane

Plane containing 1 or several sound paths or beams

Fig. 3.7: 2 beams in 1 plane

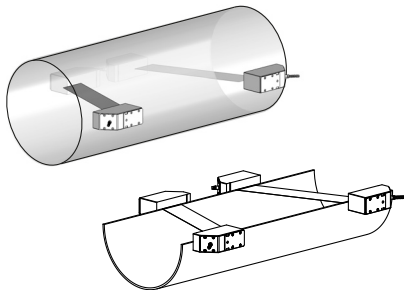
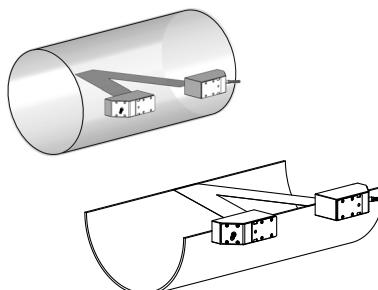
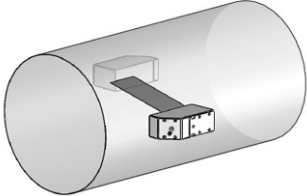
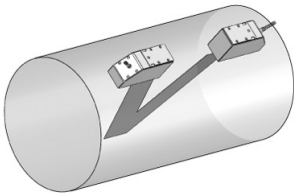
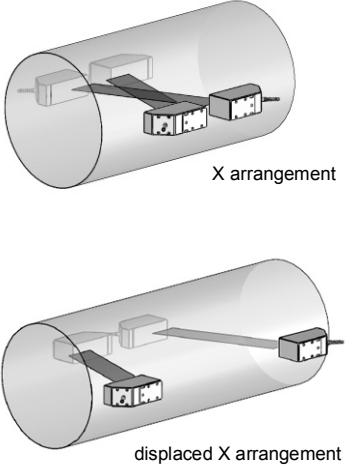
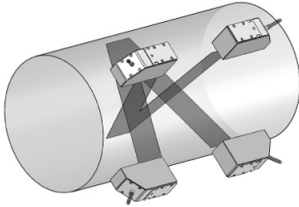

Fig. 3.8: 2 sound paths in 1 plane



3.2.2 Examples

diagonal arrangement with 1 beam	reflection arrangement with 1 beam
<p>1 transducer pair 1 sound path 1 beam 1 plane</p> 	<p>1 transducer pair 2 sound paths 1 beam 1 plane</p> 

diagonal arrangement with 2 beams	reflection arrangement with 2 beams and 2 planes
<p>2 transducer pairs 2 sound paths 2 beams 1 plane</p>  <p>X arrangement</p> <p>displaced X arrangement</p>	<p>2 transducer pairs 4 sound paths 2 beams 2 plane</p> 

3.3 Acoustic penetration

The pipe has to be acoustically penetrable at the measuring point. The acoustic penetration is given when pipe and fluid do not attenuate the sound signal so strongly that it is completely absorbed before reaching the second transducer.

The attenuation caused by the pipe and the fluid depends on:

- kinematic viscosity of the fluid
- proportion of gas bubbles and solid particles in the fluid
- deposits on the inner pipe wall
- pipe material

The following requirements have to be met at the measuring point:

- pipe always completely filled
- no deposits of solid particles in the pipe
- no formation of gas bubbles

Notice!

Even bubble-free fluids can form gas bubbles when the fluid expands, e.g., before pumps and after great cross-section extensions.

Observe the following notes on the selection of the measuring point:

Horizontal pipe

Select a measuring point where the transducers can be mounted laterally on the pipe, allowing the sound waves to propagate horizontally in the pipe. Thus, solid particles on the bottom of the pipe or gas bubbles in the pipe's upper part are prevented from influencing the propagation of the signal.

Fig. 3.9: Recommended transducer mounting position

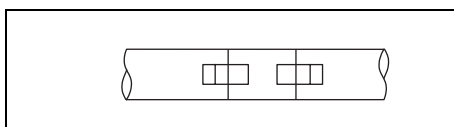
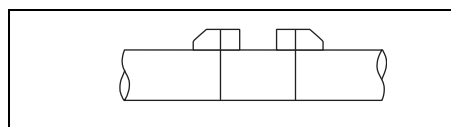

Fig. 3.10: Disadvantageous transducer mounting position



Vertical pipe

Select the measuring point at a pipe section where the fluid flows upward. The pipe has to be completely filled.

Fig. 3.11: Recommended transducer mounting position

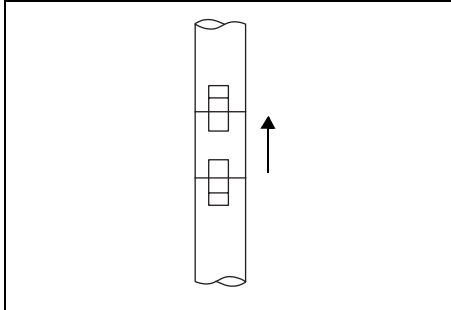
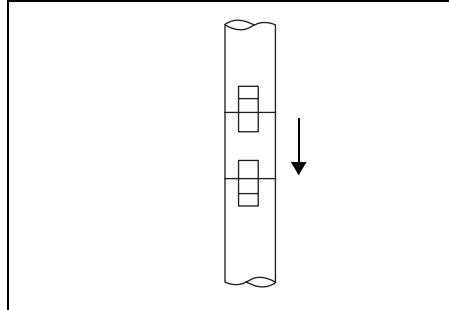

Fig. 3.12: Disadvantageous transducer mounting position



Free inlet or outlet pipe section

Select the measuring point at a pipe section where the pipe cannot run empty.

Fig. 3.13: Recommended transducer mounting position

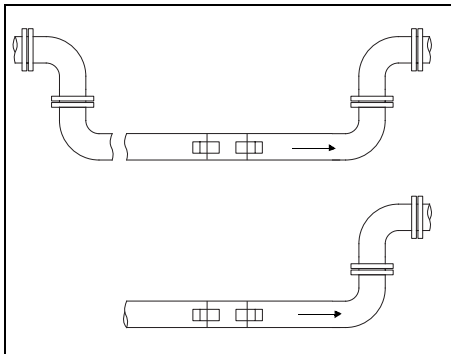
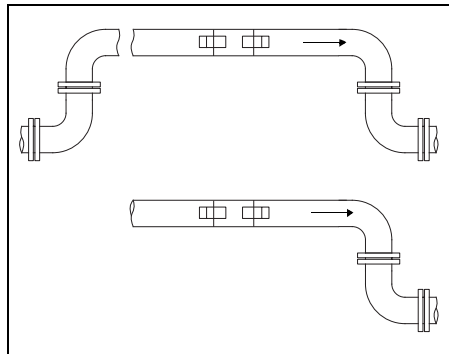

Fig. 3.14: Disadvantageous transducer mounting position



3.4 Undisturbed flow profile

Some flow elements (e.g., elbows, valves, pumps, reducers) distort the flow profile in their vicinity. The axisymmetrical flow profile in the pipe needed for correct measurement is no longer given. A careful selection of the measuring point helps to reduce the impact of disturbances.

It is most important that the measuring point is chosen at a sufficient distance from any disturbances. Only then it can be assumed that the flow profile in the pipe is fully developed. However, measuring results can be obtained even if the recommended distance to disturbances cannot be met for practical reasons (no ideal inflow, see section 13.2.4).

The recommended straight inlet and outlet pipe lengths for different types of flow disturbances are shown in the following table.

Tab. 3.1: Recommended distance from disturbance
D – nominal pipe diameter at the measuring point
l – recommended distance between disturbance and transducer position

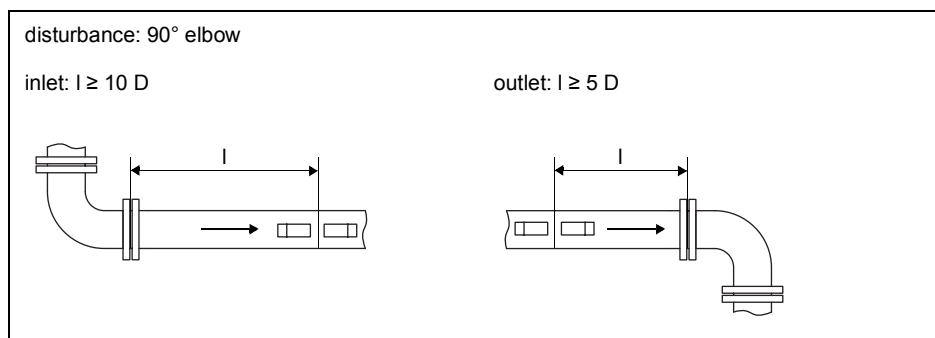

Tab. 3.1: Recommended distance from disturbance
 D – nominal pipe diameter at the measuring point
 l – recommended distance between disturbance and transducer position

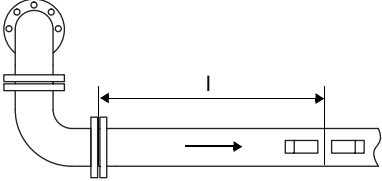
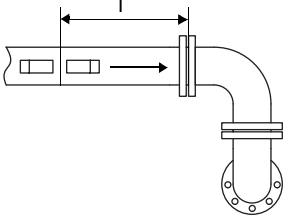
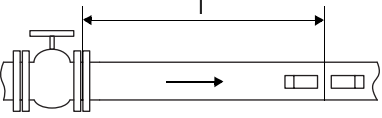
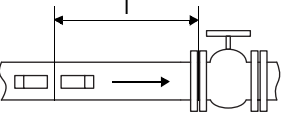
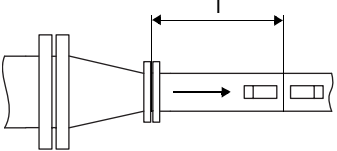
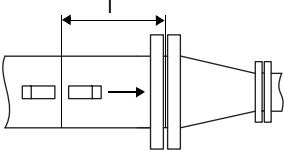
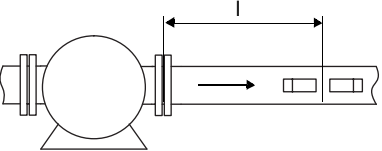
disturbance: 2 × 90° elbow on different planes inlet: $l \geq 40 D$		outlet: $l \geq 5 D$	
			
disturbance: valve inlet: $l \geq 40 D$		outlet: $l \geq 5 D$	
			
disturbance: reducer inlet: $l \geq 10 D$		outlet: $l \geq 5 D$	
			
disturbance: pump inlet: $l \geq 20 D$			
			

4 Product description

4.1 Measuring system

The measurement system consists of a transmitter, the ultrasonic transducers and the pipe on which the measurement is carried out.

Fig. 4.1: Example of a measurement arrangement

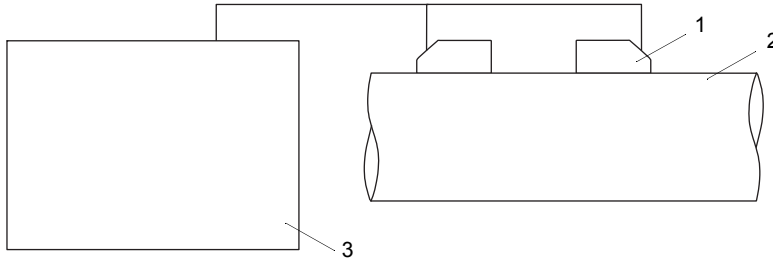

- 1 – transducer
- 2 – pipe
- 3 – transmitter

The transducers are mounted on the outside of the pipe. They send and receive ultrasonic signals through the fluid.

The transmitter controls the measuring cycle, eliminates noise signals and analyzes useful signals. The measured values can be displayed, used for calculations and transmitted.

4.2 Handling concept

The transmitter is operated via the keyboard.

By pressing **4** or **6** the following program branches are displayed consecutively:

- Parameters
- Measurement
- Options
- Special functions

The program branch is displayed between 2 arrows **◀▶**.

Fig. 4.2: Display of the program branch Parameters

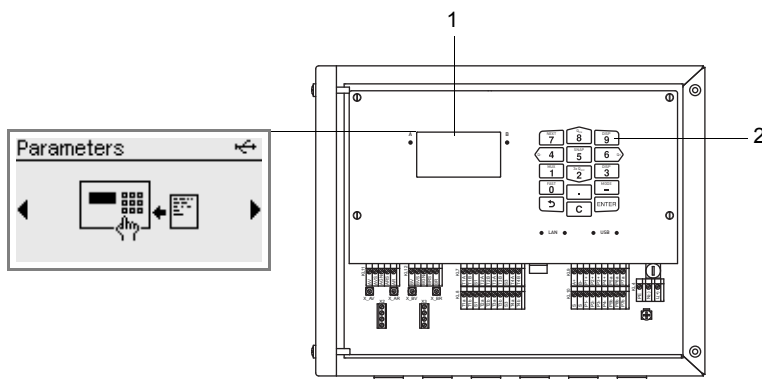

- 1 – display
- 2 – keyboard

Tab. 4.1: Description of the program branches

program branch	description
Parameters	Before starting a measurement, the transducer, pipe and fluid parameters have to be entered in the program branch <code>Parameters</code> .
Measurement	After activating the measuring channels and the input of the transducer distance, the measurement is started in the program branch <code>Measurement</code> .
Options	Channel-related settings are carried out in the program branch <code>Options</code> as e.g., selection of the physical quantity, selection of the unit of measurement, input of the damping factor, assignation of the inputs.
Special functions	Global settings, relating the transmitter and all measuring channels, are carried out in the program branch <code>Special functions</code> , as e.g. system settings (language, key lock), measuring settings, communication, data logger, snaps, configuration of inputs.

After starting up the transmitter for the first time, settings according to language, time, date and units of measurement have to be made. The program branch `Parameters` will be displayed.

Any further start-up will display the measured value in case the measurement was not stopped before the transmitter has been disconnected from the power supply. If the measurement is stopped, the program branch `Parameters` will be displayed.

After starting the measurement, the parameter settings or configuration of the transmitter outputs can be displayed without interrupting the measurement. A change is not possible. For this, the measurement has to be stopped.

4.3 Display

Structure

Fig. 4.3: Menu item of the program branch Parameters

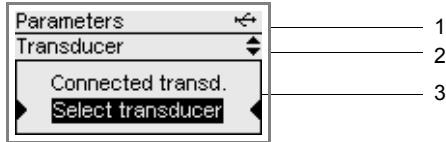

- 1 – program branch
- 2 – menu item currently edited
- 3 – area for scroll lists, selection fields or input fields

Tab. 4.2: Navigation

horizontal scroll list	vertical scroll list	selection fields	input fields
<ul style="list-style-type: none"> • scroll horizontally with key 4 or 6 	<ul style="list-style-type: none"> • scroll vertically with key 8 or 2 	<ul style="list-style-type: none"> • scroll horizontally with key 4 or 6 • activate/deactivate with key 2 or 8 	<ul style="list-style-type: none"> • input via the 10 numerical keys of the keyboard • delete with key C

Status indications

Several symbols are used for the status indications.

Fig. 4.4: Status indications (line 1)

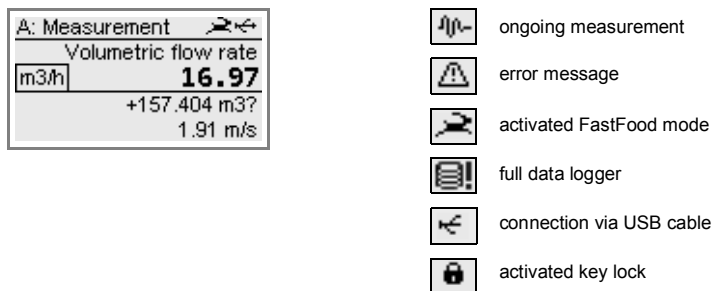



4.4 Keyboard





The keyboard has 15 keys, including the 3 function keys: ENTER,  and C.

Some key have multiple functions. They can be used to enter data, to navigate through scroll lists as well as to execute special functions (e.g., reset of totalizers).





Tab. 4.3: General functions

ENTER	confirmation of selection or input
 + C + ENTER	Reset: press these 3 keys simultaneously to correct a malfunction. The reset has the same effect as a restart of the transmitter. Stored data are not affected.
 + C	INIT: When initializing the transmitter, all settings are reset to the factory settings.









Tab. 4.4: Navigation

	During the parameter input: short press: return to the previous menu item long press (several seconds): return to the beginning of the program branch During the measurement: display of scroll list: Stop measurement, Show parameters, Show measurement
 	scroll to the left/right through a scroll list
 	scroll upwards/downwards through a scroll list
ENTER	confirmation of a menu

Tab. 4.5: Input of numbers

 ... 	input of the number pictured on the key
	sign for the input of negative values
	decimal marker
C	deletion of values After the value has been deleted, the previous value will be displayed.
ENTER	confirmation of the input

Tab. 4.6: Input of text

 	positioning of the cursor
	"A" is displayed and capitalization is activated
	"Z" is displayed and capitalization is activated
	toggling between upper and lower case
 	selection of the previous/next character
	deletion of a character and insertion of a blank
ENTER	confirmation of the input

5 Transport and storage

Caution!

**When packaging, the transmitter can fall down.**

There is a danger of crushing body parts or damaging the measuring equipment.

- Secure the transmitter against falling during packaging.
- Wear the required personal protective equipment.
- Observe the applicable rules.

Caution!

**When lifting, the center of gravity of the transmitter can be displaced within the cardboard box. The transmitter can fall down.**

There is a danger of crushing body parts or damaging the measuring equipment.

- Secure the transmitter against falling during transport.
- Wear the required personal protective equipment.
- Observe the applicable rules.

5.1 Transport

The measuring equipment must be packaged properly for transport. For weight indications, see technical specification.

- Use, if possible, the original packaging by FLEXIM or an equivalent cardboard box.
- Position the transmitter, transducers and accessories in the middle of the cardboard box.
- Fill any voids with appropriate packaging material (e.g., paper, foam, bubble wrap).
- Protect the cardboard box against humidity.

5.2 Storage

Store the measuring equipment in a dry place.

6 Mounting

Warning!



Installation, connection and start-up by unauthorized and unqualified personnel

This may result in personal or material damage or dangerous situations.

→ Any work on the transmitter has to be carried out by authorized and qualified personnel.

Danger!



Working in mines or cramped confines

Risk of intoxication and/or asphyxiation because of emerging gases, risk of injuries because of cramped conditions.

→ Wear the required personal protective equipment.

→ Observe the applicable rules.

Caution!



Safety and accident prevention regulations for electrical systems and equipment

Failure to observe these regulations may lead to severe injuries.

→ Observe the safety and accident prevention regulations for electrical systems and equipment.

Caution!



Touching hot or cold surfaces

This may result in injuries (e.g., thermal damages).

→ Observe the ambient conditions at the measuring point during installation.

→ Wear the required personal protective equipment.

→ Observe the applicable rules.

6.1 Transmitter

6.1.1 Opening and closing the housing

6.1.1.1 Opening

Caution!



Possible danger by opening the equipment at improper ambient conditions

Open the transmitter in safe ambient conditions only (e.g., air humidity < 90 %, no conductive pollution, no explosive atmosphere). Otherwise, additional protective measures have to be taken.

Important!

Do not use objects which may damage the housing gasket to open the housing cover.

- Loosen the screws of the transmitter housing.
- Open the housing cover of the transmitter.

6.1.1.2 Closing

Transmitter with stainless steel housing

- Close the housing cover.
- Tighten the screws of the transmitter housing with a max. torque of 1 Nm.

Fig. 6.1: Transmitter

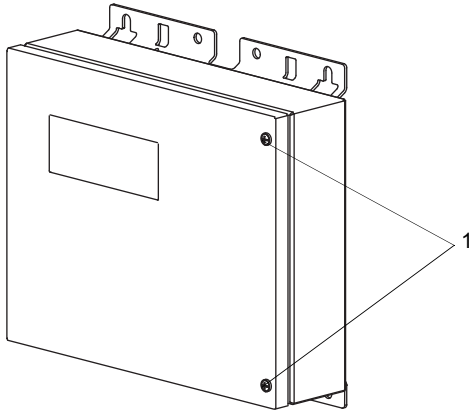

1 – screws

Transmitter with aluminum housing

- Close the housing cover and press it slightly upward.
- Hand-tight all screws of the transmitter housing.

Fig. 6.2: Transmitter

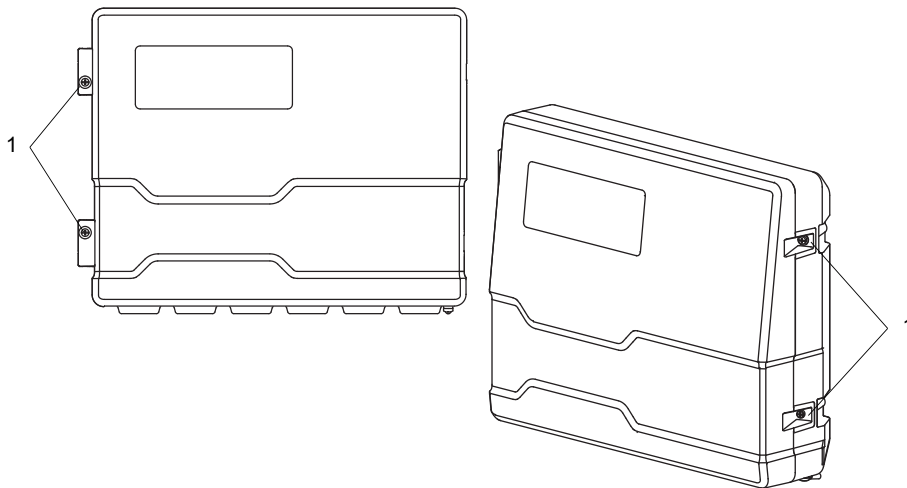

1 – screws

6.1.2 Installation of the transmitter

Notice!

Install the equipment in a shady place and cable glands facing downward. Observe the temperature and weight indications according to the technical specification when choosing the place of installation and fixation elements.

6.1.2.1 Wall mounting

Transmitter with stainless steel housing

- Fix the transmitter to the wall using 4 screws.

Fig. 6.3: Transmitter (dimensions in mm)

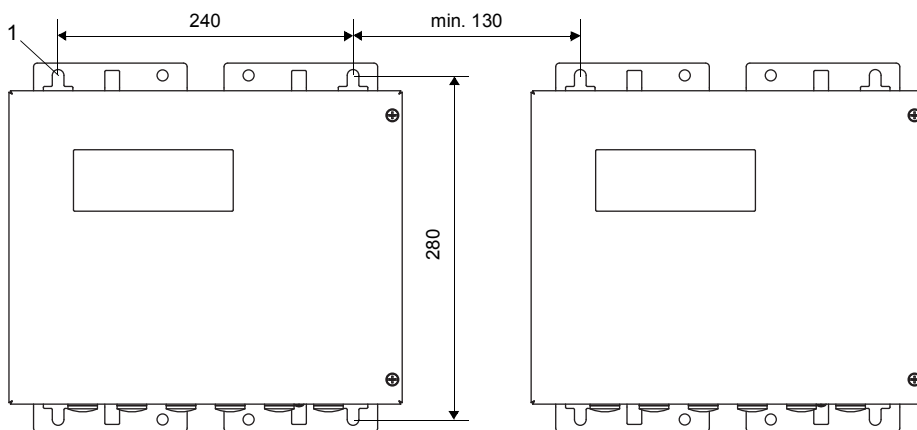

1 – fixing hole for wall mounting \varnothing 9.5

Transmitter with aluminum housing

- Fix the wall mount (2) with 3 countersunk-head screws (3) firmly to the wall.
- Attach the transmitter (1) to the lower hooks (7) of the wall mount.
- Fix the transmitter to the wall mount by locking the stop bolt (4) into the destined hole and by firmly tightening the screw (5).

Fig. 6.4: Transmitter (dimensions in mm)

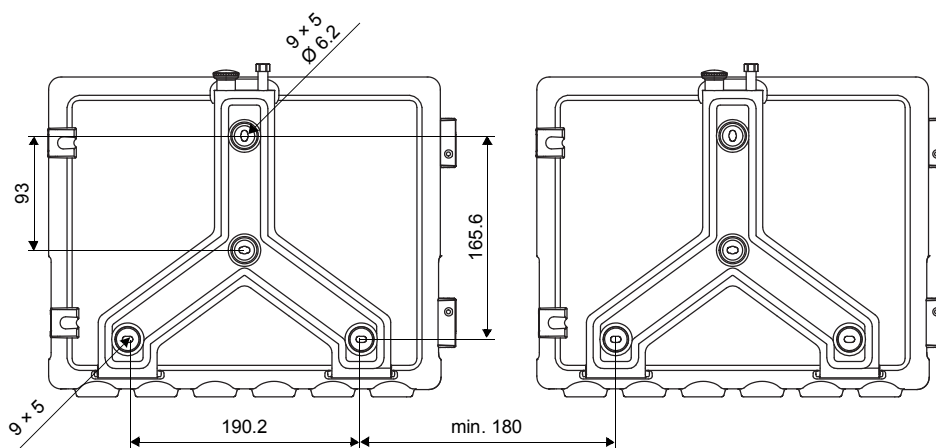
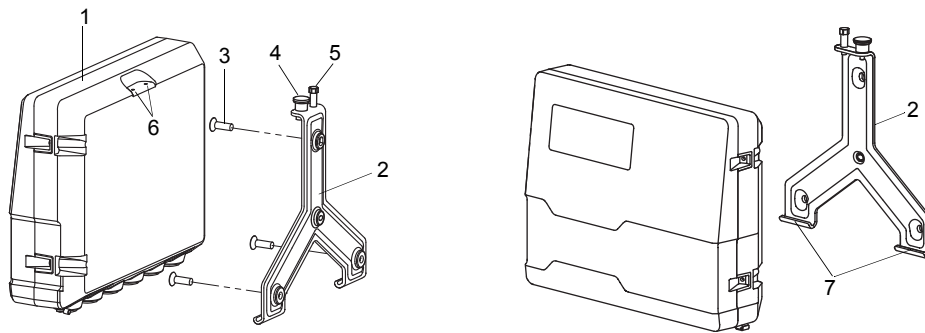

Fig. 6.5: Installation view



- 1 – transmitter
- 2 – wall mount
- 3 – countersunk-head screw
- 4 – stop bolt
- 5 – screw
- 6 – hole
- 7 – hooks

6.1.2.2 Pipe mounting

Notice!

The pipe has to be sufficiently stable to withstand the pressure exerted by the transmitter and the shackles.

Transmitter with stainless steel housing

Installation on a 2" pipe

- Position the transmitter and the shackle (1) on the pipe.
- Fix the transmitter with the shackle to the pipe by tightening the nuts (2).

Mounting on a pipe > 2"

The pipe mounting kit is fixed to the pipe by using tension straps.

Caution!



The edge of the tension strap is very sharp.

Risk of injury!

- Debur sharp edges.
- Wear the required personal protective equipment.
- Observe the applicable rules.

- Fix the transmitter to the pipe by using tension straps instead of shackles.

Fig. 6.6: Installation view

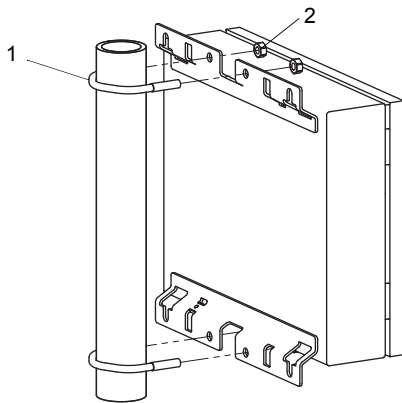

- 1 – shackle
- 2 – nut

Transmitter with aluminum housing

Notice!

For the mounting on pipes the pipe mounting kit, consisting of 2 band clamps, 2 countersunk-head screws and 2 washers, is needed. The distance of the band clamps has to be identical to the holes on the wall mount.

- Fix the band clamps (6) with 2 countersunk-head screws (4) firmly to the wall mount (1). Take care to place the washers (7) between the wall mount and the band clamp.
- Fix the wall mount with the band clamps to the pipe.
- Attach the transmitter to the lower hooks (8) of the wall mount.
- Fix the transmitter to the wall mount by locking the stop bolt (2) into the destined hole and by firmly tightening the screw (3).

Fig. 6.7: Installation view

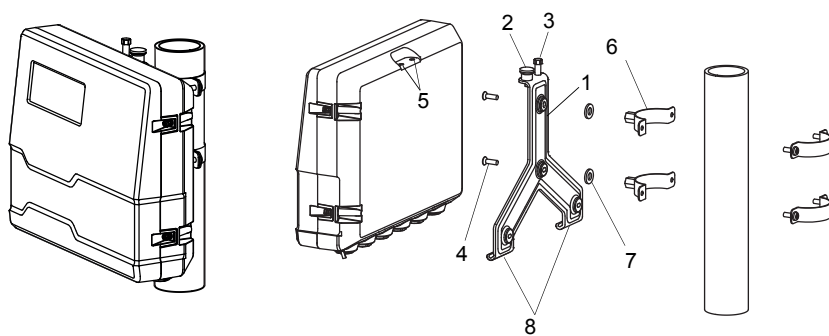

- 1 – wall mount
- 2 – stop bolt
- 3 – screw
- 4 – countersunk-head screw
- 5 – holes
- 6 – band clamp
- 7 – washer
- 8 – hooks

6.2 Transducers

Caution!



Warning of severe injuries from hot or cold components

Touching hot or cold components can lead to severe injuries (e.g., thermal damage).

- Any mounting, installation or connection work has to be concluded.
- Any work on the measuring point during the measurement is prohibited.
- Observe the ambient conditions at the measuring point during installation.
- Wear the required personal protective equipment.
- Observe the applicable rules.

6.2.1 Preparation

6.2.1.1 Measuring point selection

The correct selection of the measuring point is crucial for achieving reliable measurement results and a high measurement accuracy.

A measurement on a pipe is possible if:

- the ultrasound propagates with a sufficiently high amplitude
- the flow profile is fully developed

The correct selection of the measuring point and the correct transducer positioning guarantee that the sound signal will be received under optimum conditions and evaluated correctly.

Because of the variety of applications and the different factors that influence the measurement, there is no standard solution for the transducer positioning.

The measurement is influenced by the following factors:

- diameter, material, lining, wall thickness and shape of the pipe
- fluid
- gas bubbles in the fluid
- Avoid measuring points in the vicinity of distorted or defective areas of the pipe or in the vicinity of welds.
- Avoid measuring points with deposit formation in the pipe.
- Make sure the pipe surface at the selected measuring point is even.
- Select the location of the transmitter within the transducer cable range.
- The ambient temperature at the measuring point has to be within the operating temperature range of the transmitter and the transducers (see technical specification).

If the measuring point is within an explosive atmosphere, possibly present danger zones and gases have to be determined. The transducers and the transmitter have to be appropriate for these conditions.

6.2.1.2 Pipe preparation

Caution!



Contact with grinding dust

This may result in injuries (e.g., breathing difficulties, skin reactions, eye irritations).

- Wear the required personal protective equipment.
- Observe the applicable rules.

Important!

The pipe has to be sufficiently stable to withstand the pressure exerted by the transducers and the tension straps.

Notice!

Observe the selection criteria of pipe and measuring point.

Rust, paint or deposits on the pipe absorb the sound signal. A good acoustic contact between the pipe and the transducers is obtained as follows:

- Clean the pipe at the selected measuring point.
 - If present, the paint layer has to be smoothed by grinding. The paint does not need to be removed completely.
 - Remove rust or loose paint.
- Use coupling foil or apply a bead of coupling compound along the center line of the contact surface of the transducers.
- Observe that there must be no air pockets between the transducer contact surface and the pipe wall.

6.2.1.3 Selection of the measurement arrangement

diagonal arrangement with 1 beam

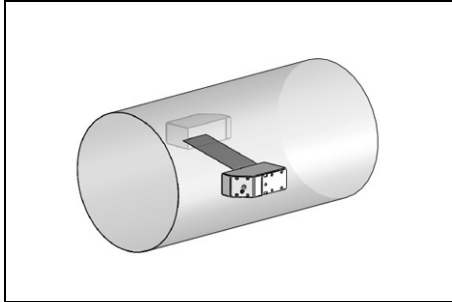

- wider flow velocity and sound speed range compared to the reflection arrangement
- use in the presence of deposits on the inner pipe wall or with strongly attenuating gases or liquids (only 1 sound path)

reflection arrangement with 1 beam

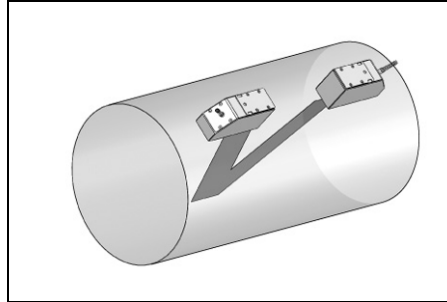

- smaller flow velocity and sound speed range compared to the diagonal arrangement
- transverse flow effects are compensated because the beam crosses the pipe in 2 directions
- higher accuracy of measurement because the accuracy increases with the number of sound paths

diagonal arrangement with 2 beams

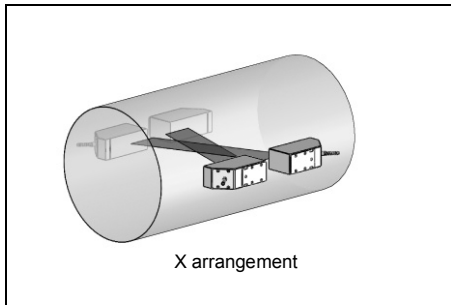

reflection arrangement with 2 beams and 2 planes

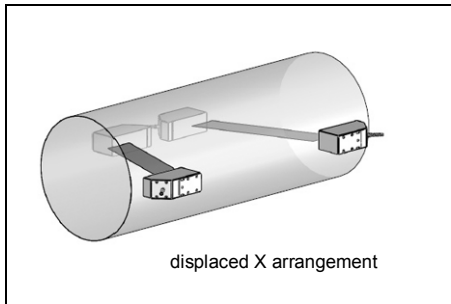
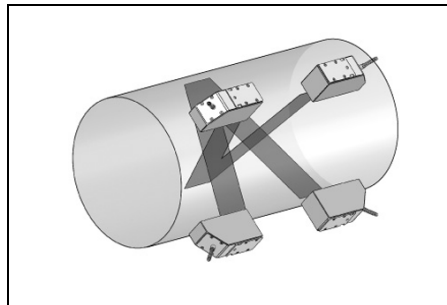

- same characteristics as reflection arrangement with 1 beams
- additional characteristic: influences of the flow profile are compensated because the measurement takes place in 2 planes

- same characteristics as diagonal arrangement with 1 beam
- additional characteristic: transverse flow effects are compensated because the measurement is conducted with 2 beams

If the measuring point is situated near an elbow, the following measurement arrangements are recommended for the selection of the sound beam plane.

vertical pipes

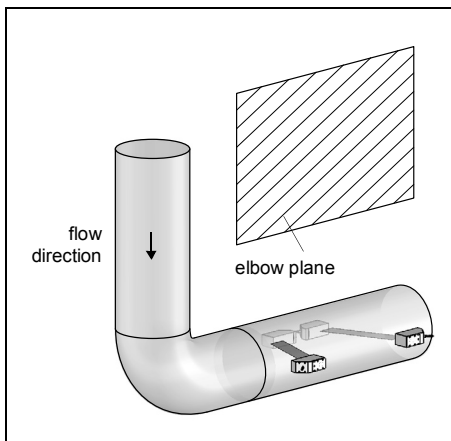

horizontal pipes

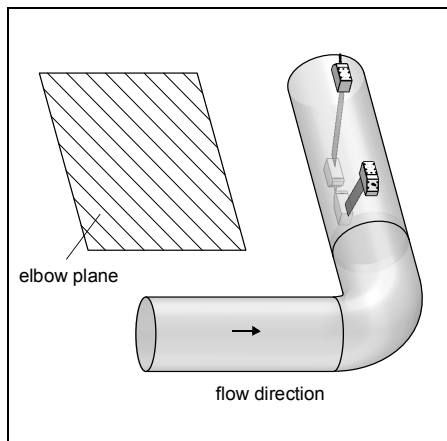

- The sound beam plan is selected at an angle of 90° to the elbow plane. The elbow is upstream of the measuring point.

- The sound beam plane is selected at an angle of $90^\circ \pm 45^\circ$ to the elbow plane. The elbow is upstream of the measuring point.

bidirectional measurements

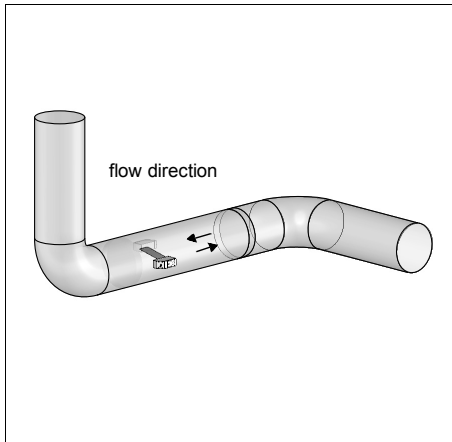

- The sound beam plane is selected according to the nearest elbow (horizontal or vertical, depending on the pipe orientation, see above).

measurement in reflection arrangement with 2 beams and 2 planes

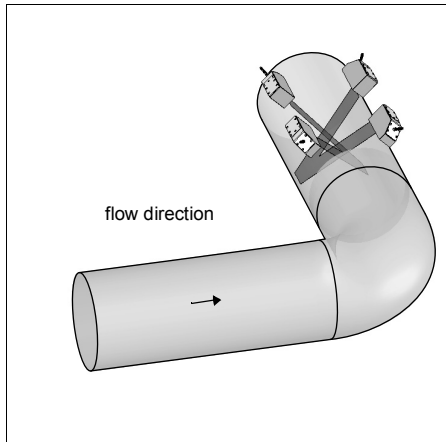

- The 2 sound beam planes are selected at an angle of 45° to the elbow plane. The elbow is upstream of the measuring point.
- On horizontal pipes, the transducers are mounted on the upper half of the pipe.

6.2.2 Installation of the transducers

6.2.2.1 Orientation of the transducers and determination of the transducer distance

Observe the orientation of the transducers. If the transducers have been mounted properly, the engravings on them form an arrow. The transducer cables show in opposite directions.

The transducer distance is measured between the inner edges of the transducers.

Fig. 6.8: Orientation of the transducers and transducer distance

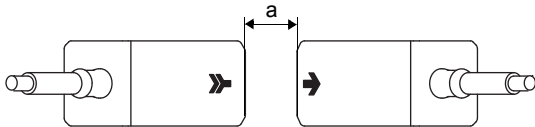

a – transducer distance

- Select the installation instructions that correspond to the supplied transducer mounting fixture.

6.2.2.2 Transducer arrangement

The transducers can be arranged in the mounting rails in different ways:

Fig. 6.9: Transducer arrangement in mounting rails

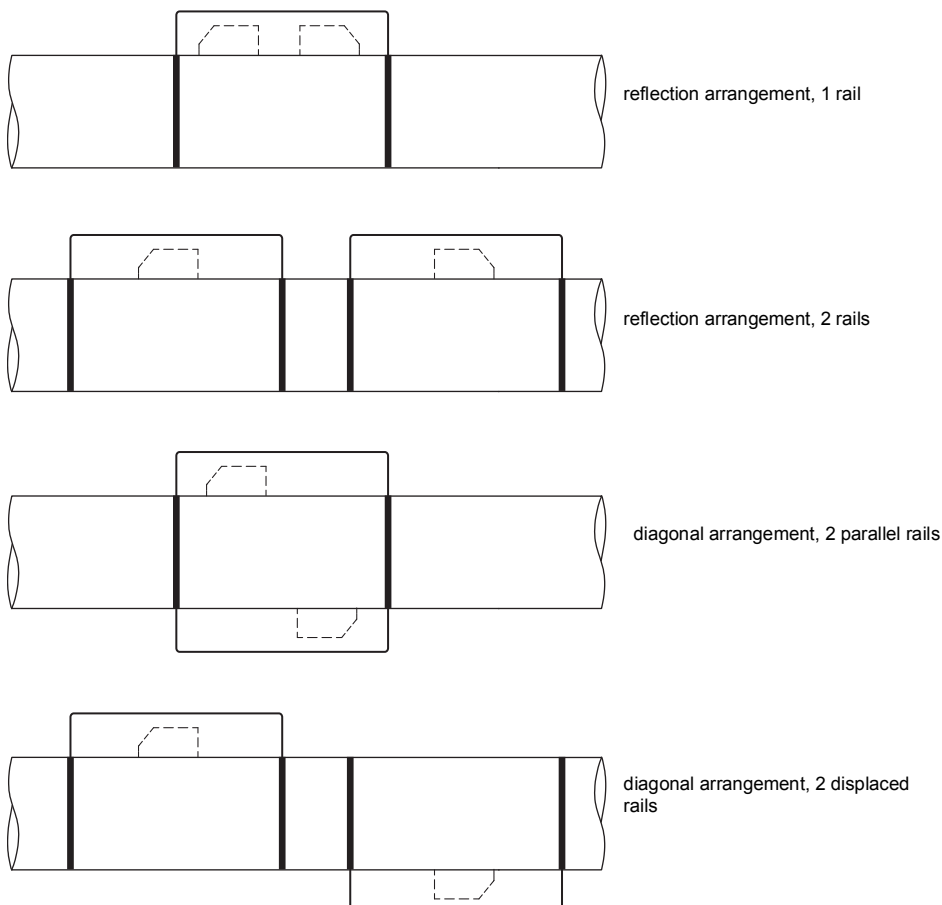

6.2.2.3 Mounting the transducer types ****LI**

If the nameplate of the transducers ****LI** is removed from the transducer cable during installation, it has afterwards to be remounted and fixed to the transducer cable using the provided cable tie. The heat shrink tubing must not be reused.

Fig. 6.10: Nameplate on the transducer cable

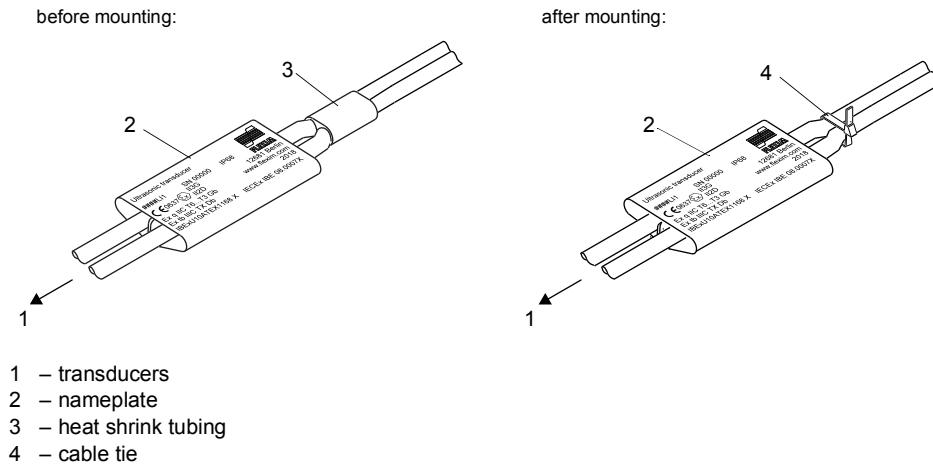

6.2.2.4 Mounting with Variofix L, PermaRail

Scope of delivery

2 × Variofix L

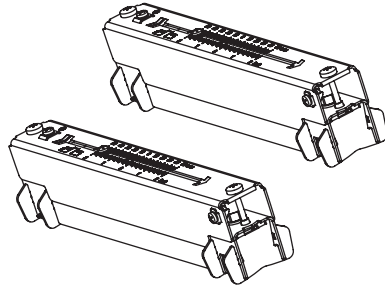

1 × transducer pair

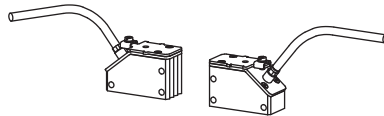

4 × quick release clasp with tension strap

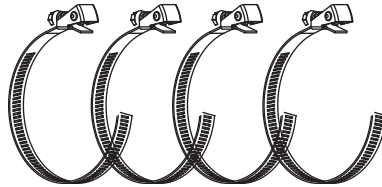

or

4 × band clamp clasp with tension strap

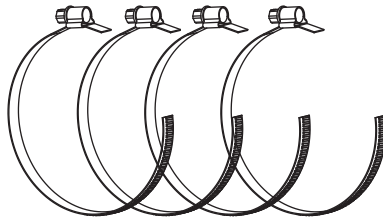

or

4 × ratchet clasp and tension strap coil

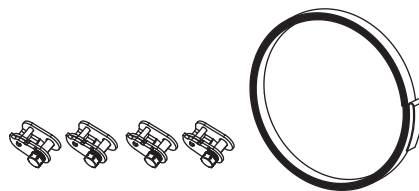

Mounting

When measuring in diagonal arrangement, the transducer mounting fixtures are mounted on opposite sides of the pipe. When measuring in reflection arrangement, the transducer mounting fixtures are mounted on the same side of the pipe. When measuring in diagonal arrangement with 2 beams in displaced X arrangement, 4 transducer mounting fixtures have to be mounted. When measuring in reflection arrangement with a small transducer distance, only 1 transducer mounting fixture has to be mounted.

Tab. 6.1: Approximate values for the mounting of both transducers in a Variofix L

transducer frequency (3rd character of the technical type)	length of the rail [mm]	transducer distance [mm]
F	368	< 94
G, H, K (****LI*)	368	< 94
G, H, K (except ****LI*)	348	< 89
M, P (Lamb wave transducers)	234	< 84
M, P (shear wave transducers)		< 100
Q	176	< 69

In the following, the mounting of 2 transducer mounting fixtures in reflection arrangement is described (1 transducer mounting fixture for each transducer).

Fig. 6.11: Transducer mounting fixture Variofix L (diagonal arrangement)

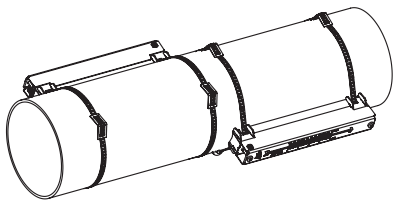
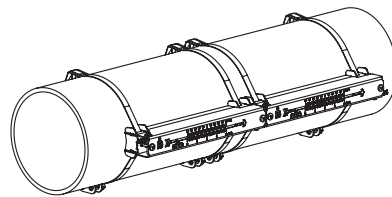

Fig. 6.12: Transducer mounting fixture Variofix L (reflection arrangement)



Overview of the mounting steps

- **step 1**
disassembly of the transducer mounting fixture Variofix L
- **step 2**
fixation of the clasps to the tension straps
- **step 3**
fixation of the tension strap to the pipe
- **step 4**
fixation of the rail to the pipe
- **step 5**
installation of the transducers in the mounting fixture Variofix L

Step 1: Disassembly of the transducer mounting fixture Variofix L

- Disassemble the transducer mounting fixture Variofix L.

Fig. 6.13: Dismounting of the transducer mounting fixture Variofix L

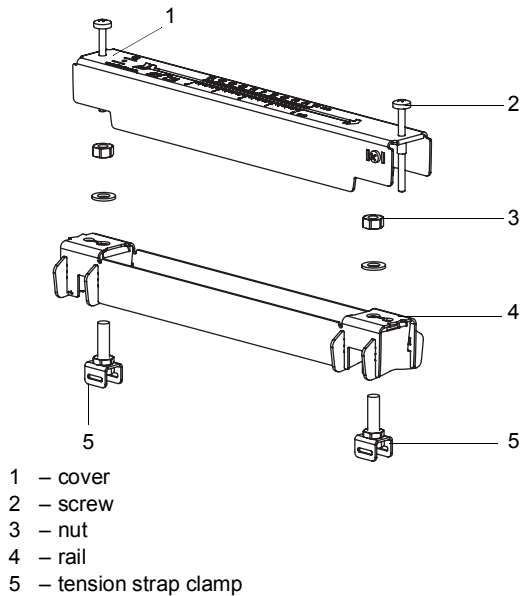
**Step 2: Fixing the clasps to the tension straps**

- Select the installation instruction of the supplied clasp:

Band clamp clasp

The clasp is fixed to the tension strap, see Fig. 6.14.

Quick release clasp

The clasp is fixed to the tension strap, see Fig. 6.15.

- Cut the tension strap to length (pipe circumference + at least 120 mm).

Fig. 6.14: Band clamp clasp with tension strap

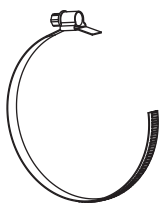
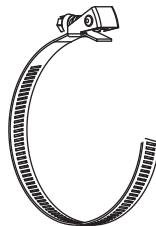

Fig. 6.15: Quick release clasp with tension strap

**Ratchet clasp**

- Cut the tension strap to length (pipe circumference + at least 120 mm).

Caution!

The edge of the tension strap is very sharp.

Risk of injury!

- Debur sharp edges.
- Wear the required personal protective equipment.
- Observe the applicable rules.

- Insert approx. 100 mm of the tension strap into part (1) and (2) of the ratchet clasp, see Fig. 6.16 a.
- Bend the tension strap.
- Insert the tension strap into part (1) of the ratchet clasp, see Fig. 6.16 b.
- Tighten the tension strap.
- Repeat the steps for the second tension strap.

Fig. 6.16: Ratchet clasp with tension strap

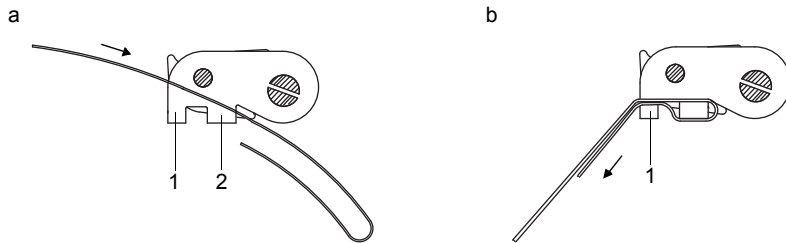

Step 3: Fixation of the tension strap to the pipe

One tension strap is fixed to the pipe. The second tension strap is mounted later.

Fig. 6.17: Tension strap with clamp and metal spring on the pipe

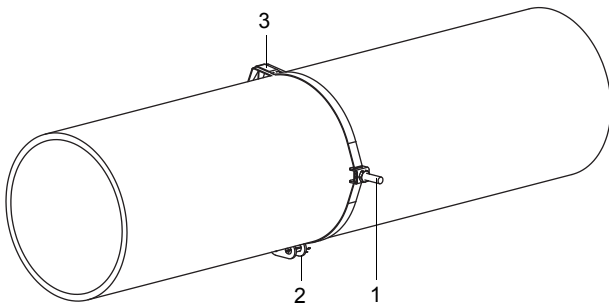

- 1 – tension strap clamp
- 2 – tension strap
- 3 – metal spring

Select the installation instruction of the supplied clasp:

Band clamp clasp

- Insert the tension strap into the tension strap clamp, see Fig. 6.18.
- Position the clasp and the tension strap clamp on the pipe, see Fig. 6.17. On a horizontal pipe, mount the tension strap clamp laterally to the pipe, if possible.
- Place the tension strap around the pipe and insert it into the clasp, see Fig. 6.20.
- Tighten the tension strap.
- Tighten the clasp screw.

Quick release clasp

- Insert the tension strap into the tension strap clamp and the metal spring, see Fig. 6.18 and Fig. 6.19.
- Position the clasp, the tension strap clamp and the metal spring on the pipe, see Fig. 6.17:
 - on a horizontal pipe, mount the tension strap clamp laterally to the pipe, if possible
 - mount the metal spring opposite to the tension strap clamp

Fig. 6.18: Tension strap with clamp

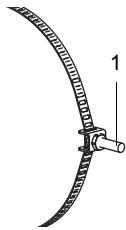

1 – tension strap clamp

Fig. 6.19: Tension strap with quick release clasp and metal spring

1 – clasp screw
2 – metal spring

Fig. 6.20: Tension strap with band clamp clasp



1 – clasp screw

- Place the tension strap around the pipe and insert it into the clasp, see Fig. 6.19.
- Tighten the tension strap.
- Tighten the clasp screw.

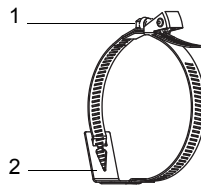
Ratchet clasp

- Insert the tension strap into the tension strap clamp and the metal spring (see Fig. 6.21). The metal spring does not have to be mounted on:
 - steel pipes
 - pipes with an outer pipe diameter < 80 mm
 - pipes that are not subjected to significant temperature fluctuations
- Position the ratchet clasp, tension strap clamp and metal spring (if necessary) on the pipe, see Fig. 6.17:
 - on a horizontal pipe, mount the tension strap clamp laterally to the pipe, if possible
 - mount the metal spring (if necessary) opposite to the tension strap clamp
- Place the tension strap around the pipe and pass it through the slot of the clasp screw, see Fig. 6.22.
- Tighten the tension strap.
- Cut off the protruding tension strap, see Fig. 6.22.

Caution!**The edge of the tension strap is very sharp.**

Risk of injury!

- Debur sharp edges.
- Wear the required personal protective equipment.
- Observe the applicable rules.

- Tighten the clasp screw.

Notice!

In order to release the screw and the tension strap, press the lever down, see Fig. 6.22.

Fig. 6.21: Tension strap with metal spring and clamp



- 1 – metal spring
- 2 – tension strap clamp

Fig. 6.22: Ratchet clasp with tension strap

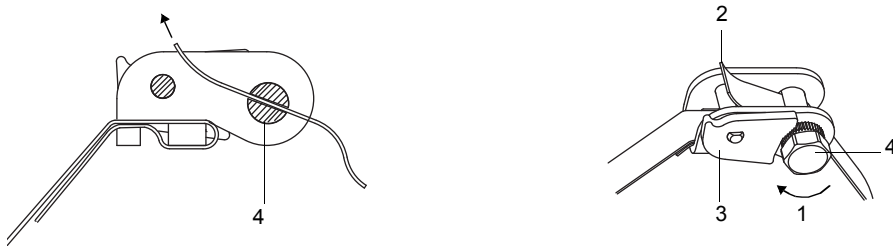

- 1 – sense of rotation
- 2 – edge
- 3 – lever
- 4 – clasp screw with slot

Step 4: Fixation of the rail to the pipe

- Place the tension strap clamp (2) in the rail, see Fig. 6.23. Observe the orientation of the tension strap clamp.
- Tighten the nut of the tension strap clamp (2) slightly.
- Screw the rail to tension strap clamp (1), see Fig. 6.24.
- Tighten the nut of tension strap clamp (1), but not too firmly in order not to damage the tension strap.

Fig. 6.23: Rail with tension strap clamp

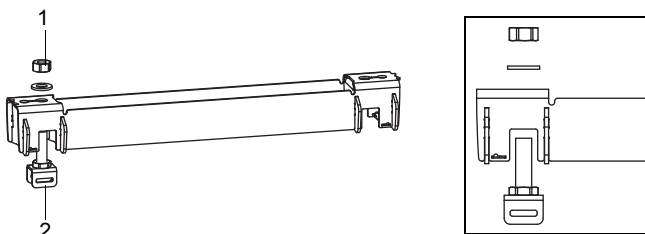

- 1 – nut
- 2 – tension strap clamp

Fig. 6.24: Rail, mounted on one side of the pipe

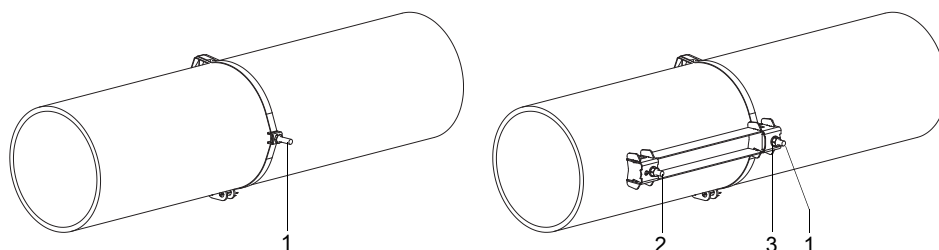

- 1 – tension strap clamp
- 2 – tension strap clamp
- 3 – nut

- Select the installation instruction of the supplied clasp:

Band clamp clasp

- Insert the tension strap into the tension strap clamp (2), see Fig. 6.25.
- Place the tension strap around the pipe and insert it into the clasp, see Fig. 6.26.
- Tighten the tension strap.
- Tighten the clasp screw.
- Tighten the nut of the tension strap clamp (2), but not too firmly in order not to damage the tension strap, see Fig. 6.25.

Fig. 6.25: Rail on the pipe

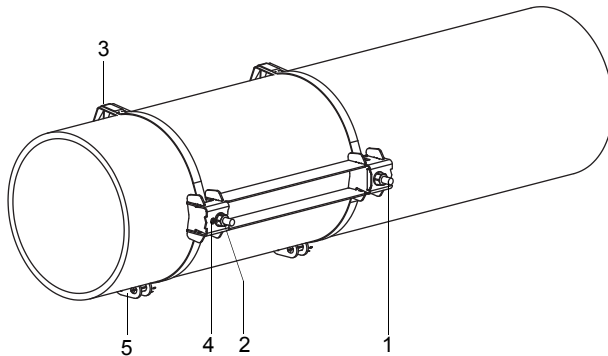

- 1 – tension strap clamp
- 2 – tension strap clamp
- 3 – metal spring
- 4 – nut
- 5 – tension strap

Quick release clasp

- Insert the tension strap into the tension strap clamp (2) and the metal spring, see Fig. 6.27 and Fig. 6.25.
- Place the tension strap around the pipe and insert it into the clasp.
- Position the metal spring opposite to the tension strap clamp (2).
- Tighten the tension strap.
- Tighten the clasp screw.
- Tighten the nut of the tension strap clamp (2), but not too firmly in order not to damage the tension strap, see Fig. 6.25.

Fig. 6.26: Tension strap with band clamp clasp



- 1 – clasp screw

Fig. 6.27: Tension strap with quick release clasp and metal spring

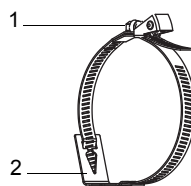

- 1 – clasp screw
- 2 – metal spring

Ratchet clasp

- Insert the tension strap into the tension strap clamp (2) and the metal spring, see Fig. 6.25 and Fig. 6.28. The metal spring does not have to be mounted on:
 - steel pipes
 - pipes with an outer pipe diameter < 80 mm
 - pipes that are not subjected to significant temperature fluctuations
- Position the ratchet clasp, tension strap clamp (2) and metal spring (if necessary) on the pipe:
- Position the metal spring opposite to the tension strap clamp.
- Place the tension strap around the pipe and pass it through the slot of the clasp screw, see Fig. 6.29.
- Tighten the tension strap.
- Cut off the protruding tension strap, see Fig. 6.29.

Caution!



The edge of the tension strap is very sharp.

Risk of injury!

- Debur sharp edges.
- Wear the required personal protective equipment.
- Observe the applicable rules.

- Tighten the clasp screw.
- Tighten the nut of the tension strap clamp (2), but not too firmly in order not to damage the tension strap, see Fig. 6.25.

Notice!

In order to release the screw and the tension strap, press the lever down, see Fig. 6.22.

Fig. 6.28: Tension strap with metal spring and clamp



- 1 – metal spring
- 2 – tension strap clamp

Fig. 6.29: Ratchet clasp with tension strap

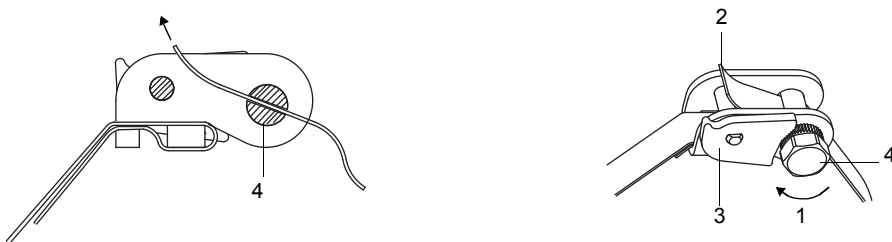

- 1 – sense of rotation
- 2 – edge
- 3 – lever
- 4 – clasp screw with slot

- Repeat the steps to fix the second rail, see Fig. 6.30.

Fig. 6.30: Pipe with 2 rails

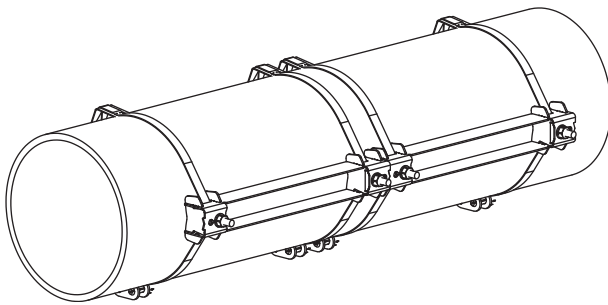

Step 5: Installation of the transducers in the mounting fixture Variofix L

- Press the transducers firmly into their clamping fixtures in the covers until they are tightly fixed. The transducer cables show in opposite directions, see Fig. 6.31.

Notice!

The arrows on the transducers and the covers have to point in the same direction.

Fig. 6.31: Installation of the transducers in the covers

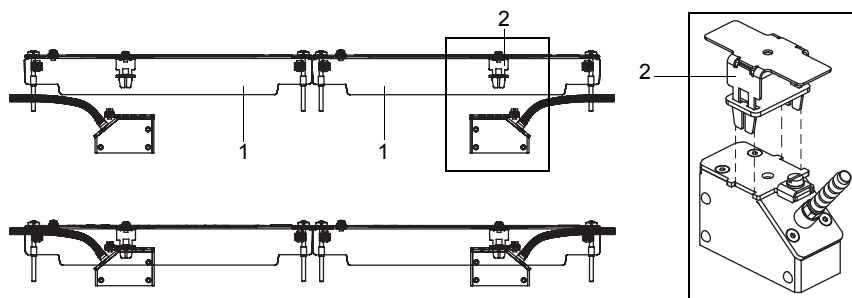

- 1 – cover
2 – transducer clamping fixture

- Adjust the transducer distance displayed by the transmitter, see Fig. 6.32.
- Fix the transducer cables with the strain relief clamp to protect them from mechanical strain, see Fig. 6.32
- Stick coupling foil (or apply some coupling compound for a short-term installation) on the contact surface of the transducers. The coupling foil can be fixed to the contact surface with some coupling compound.
- Put the covers with the transducers on the rails.
- Correct the transducer distance, if necessary.

Fig. 6.32: Adjustment of the transducer distance

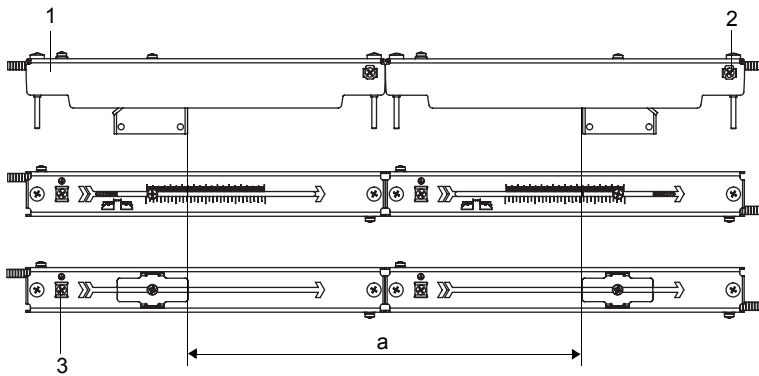

- 1 – cover
- 2 – strain relief clamp
- 3 – equipotential bonding terminal
- a – transducer distance

Notice!

Make sure that the coupling foil remains on the contact surface of the transducers. For information concerning the coupling foil, see the safety data sheet. In case a safety data sheet is required, contact FLEXIM.

- Tighten the cover screws, see Fig. 6.33.

Fig. 6.33: Variofix L with transducers on the pipe

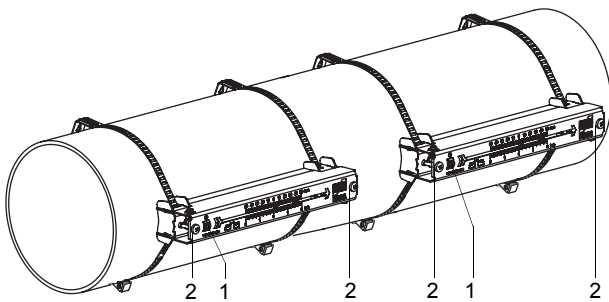

- 1 – equipotential bonding terminal
- 2 – cover screws

6.2.2.5 Mounting with Variofix C

Scope of delivery

1 × Variofix C

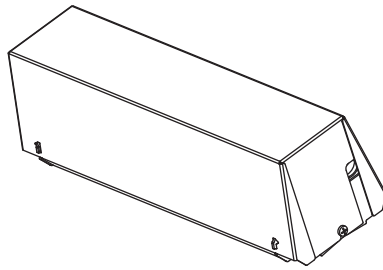

1 × transducer pair

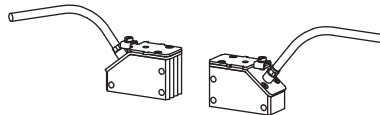

1 × tension strap coil

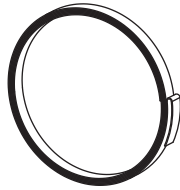

2 × ratchet clasp



Mounting

When measuring in reflection arrangement, 1 transducer mounting fixture is mounted laterally on the pipe. When measuring in diagonal arrangement, 2 transducer mounting fixtures are mounted on opposite sides of the pipe. In the following, the installation of 1 transducer mounting fixture in reflection arrangement is described.

Fig. 6.34: Transducer mounting fixture Variofix C (reflection arrangement)

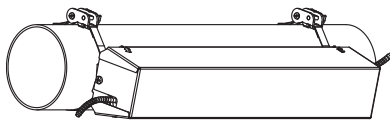
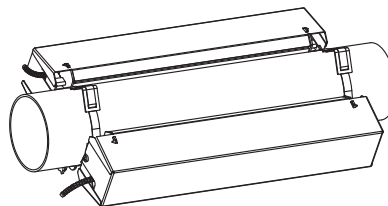

Fig. 6.35: Transducer mounting fixture Variofix C (diagonal arrangement)



Overview of the mounting steps

- **step 1**
disassembly of the transducer mounting fixture Variofix C
- **step 2**
mounting the rail
- **step 3**
installation of the transducers in the transducer mounting fixture Variofix C

Step 1: Disassembly of the transducer mounting fixture Variofix C

- Disassemble the transducer mounting fixture Variofix C.

In order to remove the cover from the rail, bend the outer sides of the cover outwards.

In order to remove the spring clip from the rail, slide it over the indentation on the rail and lift it off.

Fig. 6.36: Removal of the cover

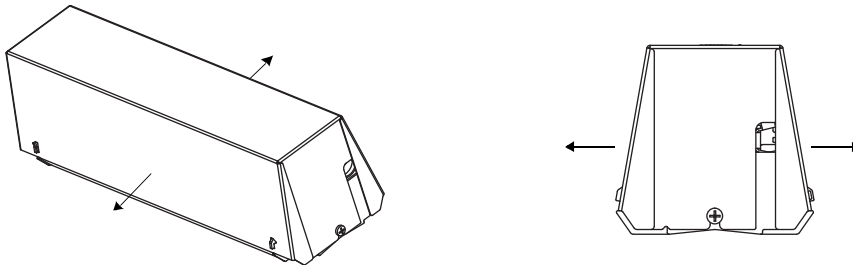
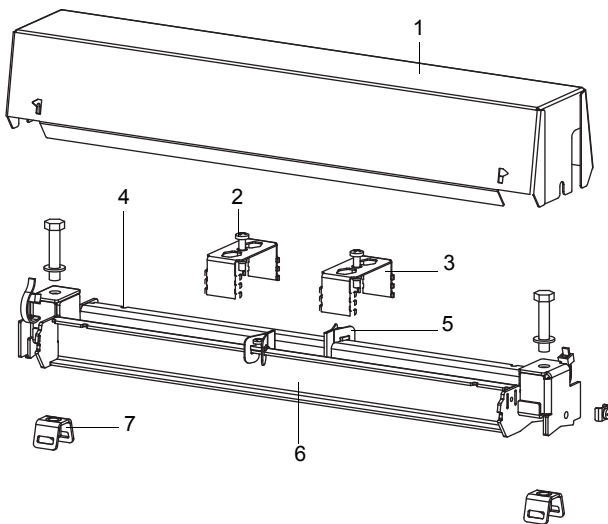

Fig. 6.37: Dismounting of the transducer mounting fixture Variofix C



- 1 – cover
- 2 – tensioning screw
- 3 – spring clip
- 4 – indentation
- 5 – spacing element
- 6 – rail
- 7 – tension strap clamp

Step 2: Mounting the rail

- Select the installation instruction of the supplied clasp:

Mounting of the rail without a clasp

- Cut the tension strap to length (pipe circumference + at least 120 mm).

Caution!



The edge of the tension strap is very sharp.

Risk of injury!

- Debur sharp edges.
- Wear the required personal protective equipment.
- Observe the applicable rules.

- Insert approx. 100 mm of the tension strap into one of the slots of the tension strap clamp and bend it, see Fig. 6.38.
- If necessary, insert the long end of the tension strap into the metal spring (see Fig. 6.39). The metal spring does not have to be mounted on:
 - steel pipes
 - pipes with an outer pipe diameter < 80 mm
 - pipes that are not subjected to significant temperature fluctuations
- Place the tension strap around the pipe, see Fig. 6.40.

Fig. 6.38: Tension strap with clamp

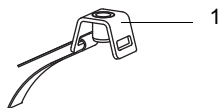

1 – tension strap clamp

Fig. 6.39: Tension strap with metal spring and clamp

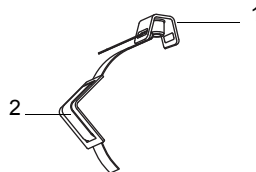

1 – tension strap clamp
2 – metal spring

- Position the tension strap clamp and metal spring (if necessary) on the pipe:
 - on a horizontal pipe, mount the tension strap clamp laterally to the pipe, if possible
 - mount the metal spring (if necessary) opposite to the tension strap clamp

Fig. 6.40: Tension strap with metal spring and tension strap clamp on the pipe

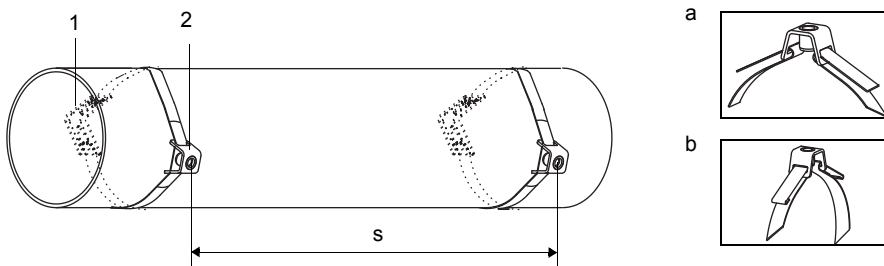

1 – metal spring
2 – tension strap clamp
s = length of the rail - 33 mm

- Insert the long end of the tension strap into the second slot of the tension strap clamp, see Fig. 6.40 a.
- Tighten the tension strap and bend it.
- Bend both ends of the tension strap (see Fig. 6.40 b).
- Repeat the steps for the second tension strap.
- Position the tension strap at the distance s (see Fig. 6.40).
- Put the rail on the tension strap clamps.
- Use the screws to fix the rail to the tension strap clamps (see Fig. 6.41).
- Tighten the screws.

Fig. 6.41: Rail on the pipe

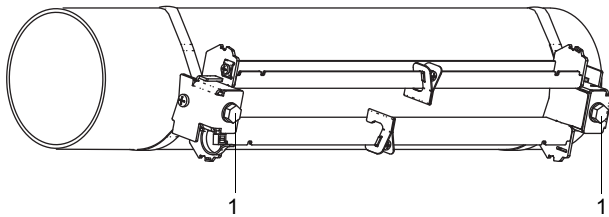

1 – screws

Mounting the rail with ratchet clasp

- Cut the tension strap to length (pipe circumference + at least 120 mm).

Caution!



The edge of the tension strap is very sharp.

Risk of injury!

- Debur sharp edges.
- Wear the required personal protective equipment.
- Observe the applicable rules.

- Insert approx. 100 mm of the tension strap into part (1) and (2) of the ratchet clasp, see Fig. 6.42 a.

Fig. 6.42: Ratchet clasp with tension strap

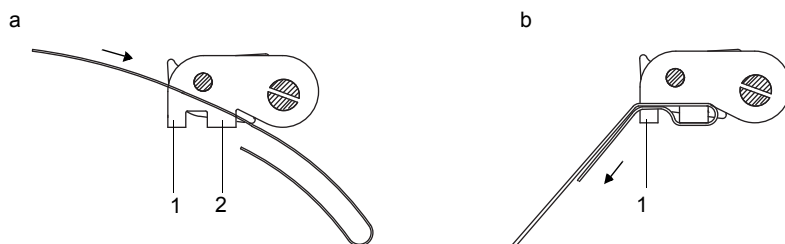

- Bend the tension strap.
- Insert the tension strap into part (1) of the ratchet clasp, see Fig. 6.42 b.
- Tighten the tension strap.
- Insert the long end of the tension strap into the tension strap clamp and the metal spring (see Fig. 6.43). The metal spring does not have to be mounted on:
 - steel pipes
 - pipes with an outer pipe diameter < 80 mm
 - pipes that are not subjected to significant temperature fluctuations
- Place the tension strap around the pipe, see Fig. 6.44.

Fig. 6.43: Tension strap with metal spring and clamp



1 – metal spring
2 – tension strap clamp

- Position the ratchet clasp, tension strap clamp and metal spring (if necessary) on the pipe:
 - on a horizontal pipe, mount the tension strap clamp laterally to the pipe, if possible
 - mount the metal spring (if necessary) opposite to the tension strap clamp
- Insert the long end of the tension strap into the second slot of the tension strap screw, see Fig. 6.45.
- Tighten the tension strap.
- Cut off the protruding tension strap, see Fig. 6.45.
- Tighten the screw of the ratchet clasp.
- Repeat the steps for the second tension strap.

Notice!
In order to release the screw and the tension strap, press the lever down, see Fig. 6.45.

Fig. 6.44: Ratchet clasp with tension strap, tension strap clamp and metal spring

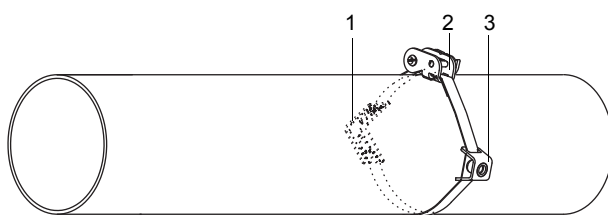

- 1 – metal spring
- 2 – Ratchet clasp
- 3 – tension strap clamp

Fig. 6.45: Ratchet clasp with tension strap



- 1 – sense of rotation
- 2 – edge
- 3 – lever
- 4 – clasp screw with slot

- Put the rail on the tension strap clamps (see Fig. 6.46).
- Fix the rail to the tension strap clamps with the screws.
- Tighten the screws.

Fig. 6.46: Rail on the pipe

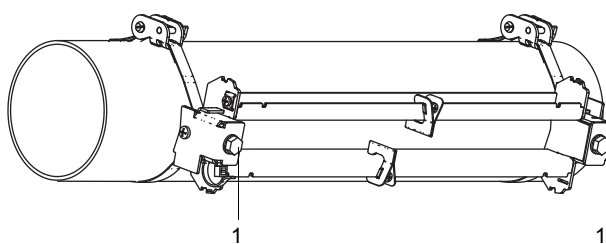

- 1 – screws

Step 3: Installation of the transducers in the transducer mounting fixture Variofix C

- Stick coupling foil (or apply some coupling compound for a short-term installation) on the contact surface of the transducers. The coupling foil can be fixed to the contact surface with a small amount of coupling compound.

Notice!

If the signal is not sufficient for the measurement, use coupling compound instead of coupling foil. For information concerning the coupling foil or coupling compound, see the safety data sheet. In case a safety data sheet is required, contact FLEXIM.

- Position the transducers on the rail in such way that the engravings on them form an arrow. The transducer cables show in opposite directions, see Fig. 6.47.
- Adjust the transducer distance displayed by the transmitter, see Fig. 6.47.
- Slide the spring clips on the transducers, see Fig. 6.48.
- Fix the transducers by tightening the tensioning screws slightly. The end of the tensioning screw has to be placed above the hole in the transducer, see Fig. 6.47 and Fig. 6.48.
- Correct the transducer distance, if necessary.
- Tighten the tensioning screws.
- Fix the spacing element on the rail to mark the transducer position, see Fig. 6.47.
- Use a cable tie to fix the transducer cables in order to protect them from mechanical strain, see Fig. 6.48.
- Put the cover on the rail, see Fig. 6.49.
- Tighten the screws on both sides of the cover.

Fig. 6.47: Transducers in the rail (spring clip not shown)

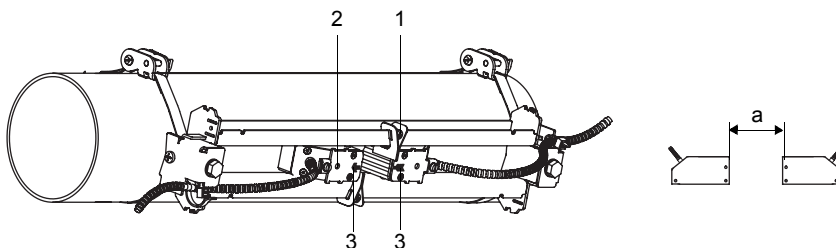

- 1 – spacing element
- 2 – hole
- 3 – engravings on the transducers
- a – transducer distance

Fig. 6.48: Transducers in the rail

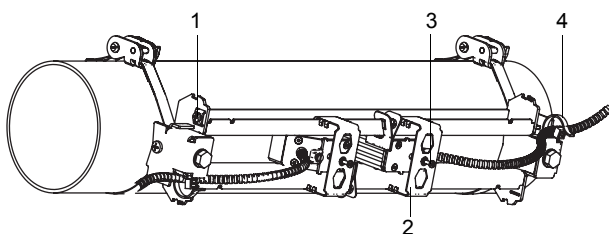

- 1 – equipotential bonding terminal
- 2 – spring clip
- 3 – tensioning screw
- 4 – cable tie

Fig. 6.49: Variofix C with transducers on the pipe

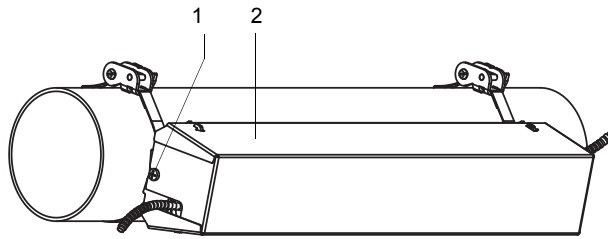

- 1 – screw
- 2 – cover

Remove the cover from the mounted transducer mounting fixture Variofix C as follows:

- Use a lever tool to remove the cover.
- Insert the lever tool in one of the 4 openings of the cover, see Fig. 6.50.
- Press the lever tool against the fixture.
- Bend the cover outwards and release it from the anchoring.
- Repeat the steps for the other 3 openings.
- Remove the cover from the rail.

Fig. 6.50: Removal of the cover

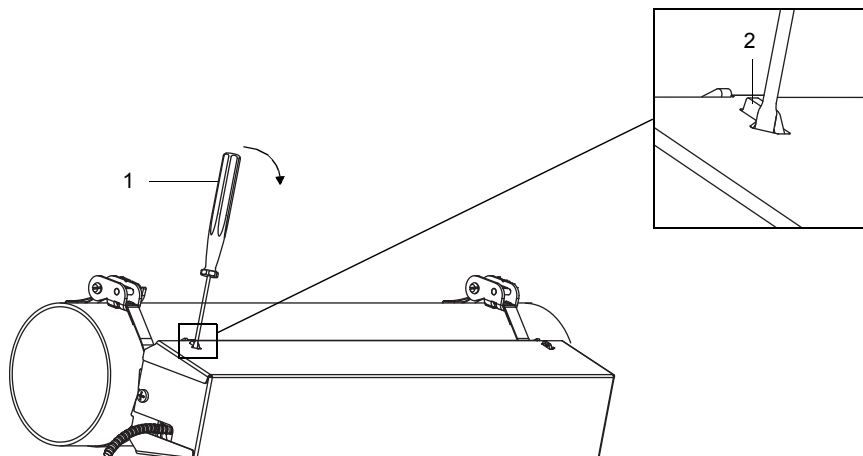

- 1 – lever tool
- 2 – fixture

7 Connection

Warning!

**Installation, connection and start-up by unauthorized and unqualified personnel**

This may result in personal or material damage or dangerous situations.

→ Any work on the transmitter has to be carried out by authorized and qualified personnel.

Danger!

**Working in mines or cramped confines**

Risk of intoxication and/or asphyxiation because of emerging gases, risk of injuries because of cramped conditions.

→ Wear the required personal protective equipment.

→ Observe the applicable rules.

Warning!

**Touching live parts**

Electric shock or arc faults can lead to severe injuries. The measuring equipment can be damaged.

→ Prior to any work on the transmitter (e.g., installation, dismantling, connection, start-up), the transmitter has to be disconnected from the power supply. It is not sufficient to remove the internal fuse of the instrument.

Caution!

**Safety and accident prevention regulations for electrical systems and equipment**

Failure to observe these regulations may lead to severe injuries.

→ Observe the safety and accident prevention regulations for electrical systems and equipment.

7.1 Transducers

It is recommended to run the cables from the measuring point to the transmitter before connecting the transducers to avoid load on the connectors.

Notice!

If transducers are replaced or added, the transducer module must also be replaced or added.

Fig. 7.1: Connection of the transducers to the transmitter

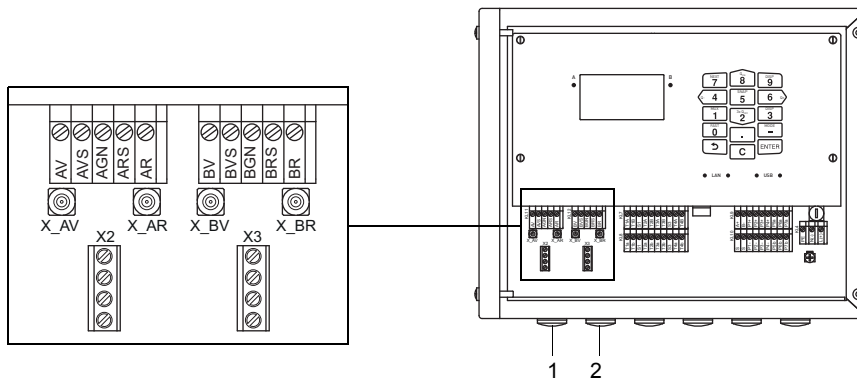

- 1 – transducers (measuring channel A)
- 2 – transducers (measuring channel B)

7.1.1 Connection of the transducer cable to the transmitter

Important!

The degree of protection of the transmitter is only ensured if all cables are tightly fitted using cable glands and the housing is firmly screwed.

- Remove the blind plug for the connection of the transducer cable.
- Open the cable gland of the transducer cable. The compression part remains in the cap nut.
- Push the transducer cable through the cap nut and the compression part.
- Prepare the transducer cable.
- Shorten the external shield and brush it back over the compression part.
- Screw the sealing ring side of the basic part into the transmitter housing.
- Insert the transducer cable into the housing.

Notice!

For good electromagnetic compatibility (EMC), it is important to ensure good electrical contact between the external shield and the cap nut (and thus the housing).

- Fix the cable gland by screwing the cap nut onto the basic part.
- Connect the transducer cable to the terminals of the transmitter.

Tab. 7.1: Terminal assignment





terminal	connection
AV	transducer  (core)
AVS	transducer  (internal shield)
ARS	transducer  (inner shield)
AR	transducer  (core)

Fig. 7.2: Connection of the transducer cable with plastic jacket and stripped ends to the transmitter



- 1 – cap nut
- 2 – compression part
- 3 – basic part
- 4 – external shield, brushed back

7.1.2 Connection of the extension cable to the transmitter

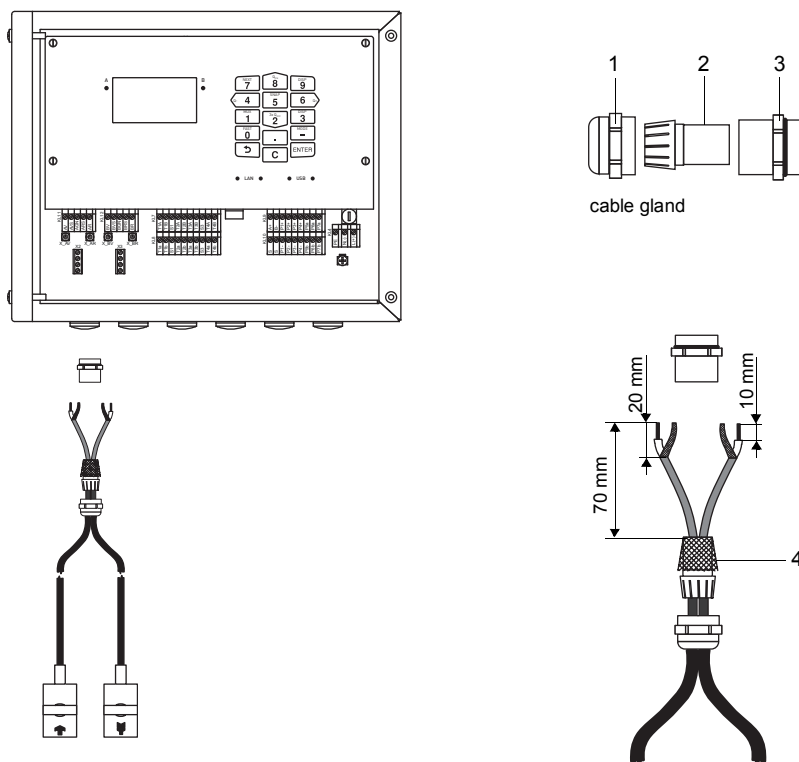
- The extension cable is connected to the transmitter via the transducer connection.
- Remove the blind plug for the connection of the transducer cable.
- Open the cable gland of the extension cable. The compression part remains in the cap nut.
- Push the extension cable through the cap nut and the compression part.
- Prepare the extension cable.
- Shorten the external shield and brush it back over the compression part.
- Screw the sealing ring side of the basic part into the transmitter housing.
- Insert the extension cable into the housing.

Notice!

For good electromagnetic compatibility (EMC), it is important to ensure good electrical contact between the external shield and the cap nut (and thus the housing).

- Fix the cable gland by screwing the cap nut onto the basic part.
- Connect the extension cable to the terminals of the transmitter.

Tab. 7.2: Terminal assignment

terminal	connection
AV	white or marked cable (core)
AVS	white or marked cable (internal shield)
ARS	brown cable (internal shield)
AR	brown cable (core)

Fig. 7.3: Connection of the extension cable to the transmitter

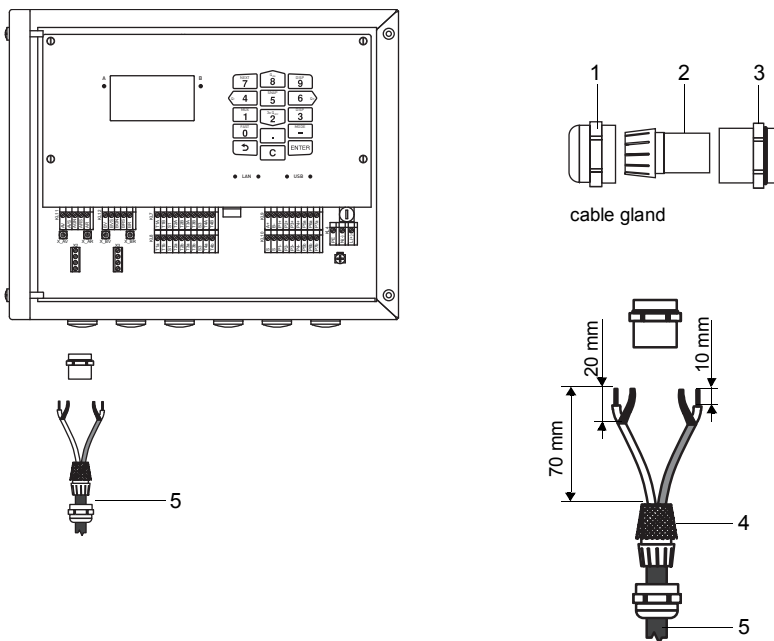

- 1 – cap nut
- 2 – compression part
- 3 – basic part
- 4 – external shield, brushed back
- 5 – extension cable

7.1.3 Connection of the transducer cable to the junction box

- Remove the blind plug for the connection of the transducer cable.
- Open the cable gland of the transducer cable. The compression part remains in the cap nut.
- Push the transducer cable through the cap nut and the compression part.
- Prepare the transducer cable.
- Shorten the external shield and brush it back over the compression part.
- Screw the gasket ring side of the basic part into the junction box.
- Insert the transducer cable into the junction box.

Notice!

For good electromagnetic compatibility (EMC), it is important to ensure good electrical contact between the external shield and the cap nut (and thus the housing).

- Fix the cable gland by screwing the cap nut onto the basic part.
- Connect the transducer cable to the terminals of the junction box.

Tab. 7.3: Terminal assignment

terminal	connection
V	transducer ↗ (core)
VS	transducer ↗ (internal shield)
RS	transducer ↘ (inner shield)
R	transducer ↘ (core)

Fig. 7.4: Connection of the transducer cable with plastic jacket and stripped ends

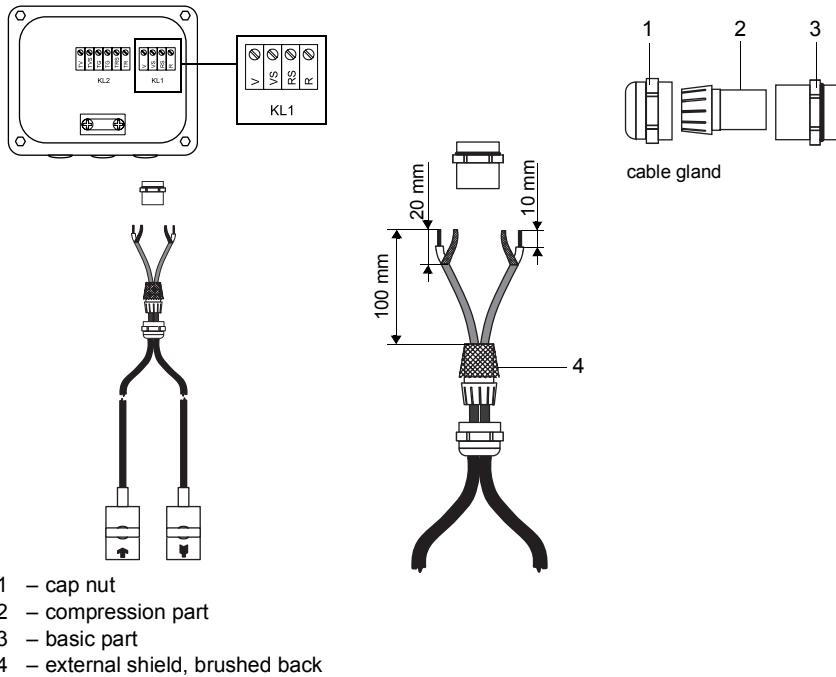

7.1.4 Connection of the extension cable to the junction box

7.1.4.1 Connection without potential separation (standard)

The connection of the extension cable to the junction box without potential separation ensures that the transducer, junction box and transmitter are on the same potential. The extension cable should always be connected in this manner, especially if power current cables are nearby. If earthing on the same potential cannot be ensured, see section 7.1.4.2.

- Remove the blind plug for the connection of the extension cable.
- Open the cable gland of the extension cable. The compression part remains in the cap nut.
- Push the extension cable through the cap nut and the compression part.
- Prepare the extension cable.
- Shorten the external shield and brush it back over the compression part.
- Screw the gasket ring side of the basic part into the junction box.
- Insert the extension cable into the junction box.

Notice!

For good electromagnetic compatibility (EMC), it is important to ensure good electrical contact between the external shield and the cap nut (and thus the housing).

- Fix the cable gland by screwing the cap nut onto the basic part.
- Connect the extension cable to the terminals of the junction box.

Tab. 7.4: Terminal assignment

terminal	connection (extension cable)
TV	white or marked cable (core)
TVS	white or marked cable (internal shield)
TRS	brown cable (internal shield)
TR	brown cable (core)
cable gland	external shield

Fig. 7.5: Connection of the extension and transducer cable to the junction box

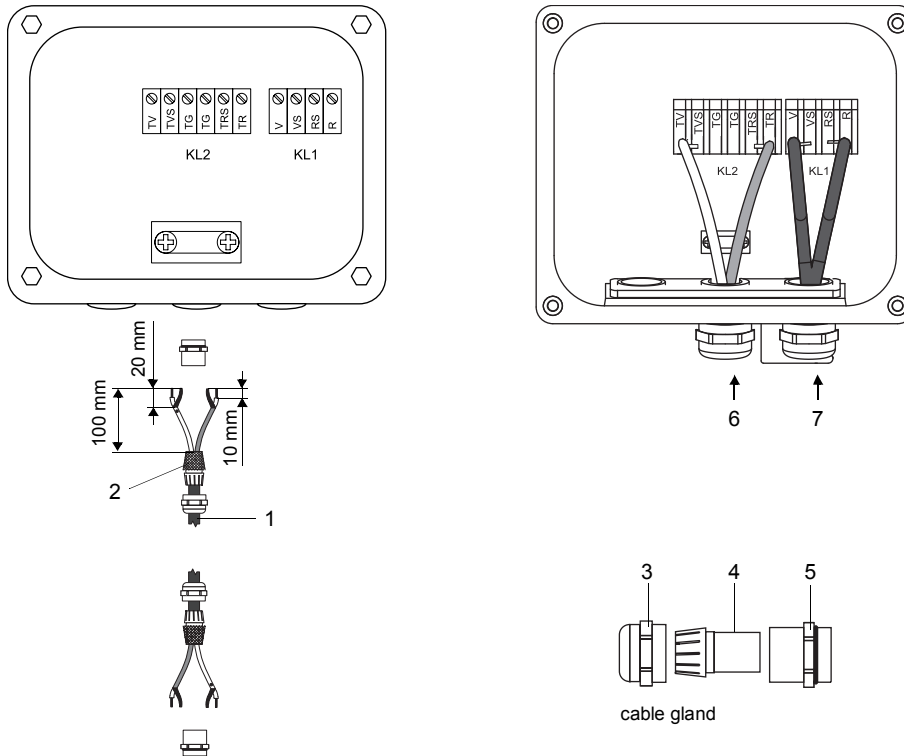

- 1 – extension cable
- 2 – external shield, brushed back
- 3 – cap nut
- 4 – compression part
- 5 – basic part
- 6 – connection of the extension cable
- 7 – connection of the transducer cable

7.1.4.2 Connection with potential separation

If earthing on the same potential cannot be ensured, e.g., in measurement arrangements with long extension cables, the extension cable and the junction box have to be electrically insulated from each other. The junction box and the transducers have to be on the same potential. Thus, no compensation currents can flow to the transmitter via the extension cable.

For measurement arrangements where the junction box and the transducers have to be electrically insulated from each other see the document TIFLUXUS_GalvSep.

- Remove the blind plug for the connection of the extension cable.
- Open the cable gland of the extension cable. The compression part remains in the cap nut.
- Push the extension cable through the cap nut, the compression part and the basic part.
- Insert the extension cable into the junction box.
- Prepare the extension cable.
- Cut the external shield and brush it back.
- Pull the extension cable back until the brushed-back external shield is below the shield terminal. The extension cable has to remain completely insulated up to the shield terminal.
- Screw the gasket ring side of the basic part into the junction box.
- Fix the cable gland by screwing the cap nut onto the basic part.

Important!
Observe the max. permissible voltage of 60 V DC between the earth potentials.

Important!
The external shield of the extension cable must not have electrical contact to the junction box. Therefore, the extension cable has to remain completely insulated up to the shield terminal.

- Fix the extension cable and the external shield to the shield terminal.
- Connect the extension cable to the terminals of the junction box.

Tab. 7.5: Terminal assignment

terminal	connection (extension cable)
TV	white or marked cable (core)
TVS	white or marked cable (internal shield)
TRS	brown cable (internal shield)
TR	brown cable (core)
shield terminal	external shield

Fig. 7.6: Connection of the extension and transducer cable to the junction box

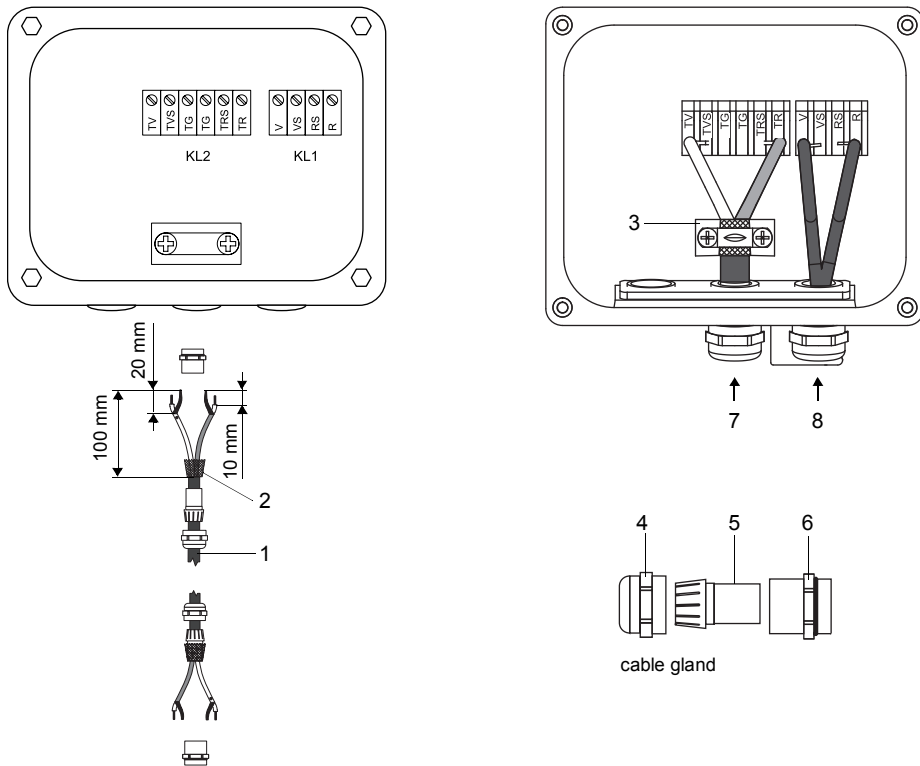

- 1 – extension cable
- 2 – external shield
- 3 – shield terminal
- 4 – cap nut
- 5 – compression part
- 6 – basic part
- 7 – connection of the extension cable
- 8 – connection of the transducer cable

7.1.5 Transducer module (SENSPROM)

The transducer module contains important transducer data for the operation of the transmitter with transducers. If transducers are replaced or added, the transducer module must also be replaced or added.

Notice!

The serial numbers of the transducer module and the transducer have to be identical. A wrong or incorrectly connected transducer module will lead to incorrect measured values or to a measurement failure.

The transducer module is connected to the terminals of the transmitter.

- Disconnect the transmitter from the power supply.
- Connect the transducer module to the corresponding terminal. Terminal X2 is assigned to the transducers of measuring channel A, terminal X3 to the transducers of measuring channel B.
- Connect the transmitter to the power supply.
- Enter all parameters of the program branch *Parameters*.
- Start the measurement.

Fig. 7.7: Transducer module

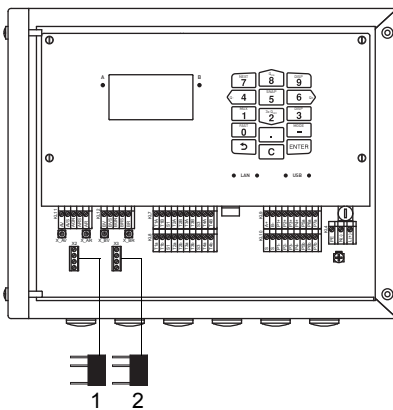

- 1 – transducer module (measuring channel A)
- 2 – transducer module (measuring channel B)

7.2 Power supply

The installation of the power supply is carried out by the operator. The operator has to provide an overcurrent protector (fuse or similar device) disconnecting all energizing wires in case of an inadmissible high current consumption. The impedance of the protective earth has to be low ohmic in order not to allow touch voltage pass the permissible limit. The equipotential bonding terminal serves as functional earth of the transmitter.

Important!

The degree of protection of the transmitter will only be guaranteed if the power cable fits firmly and tightly in the cable gland.

Fig. 7.8: Equipotential bonding terminal on the transmitter

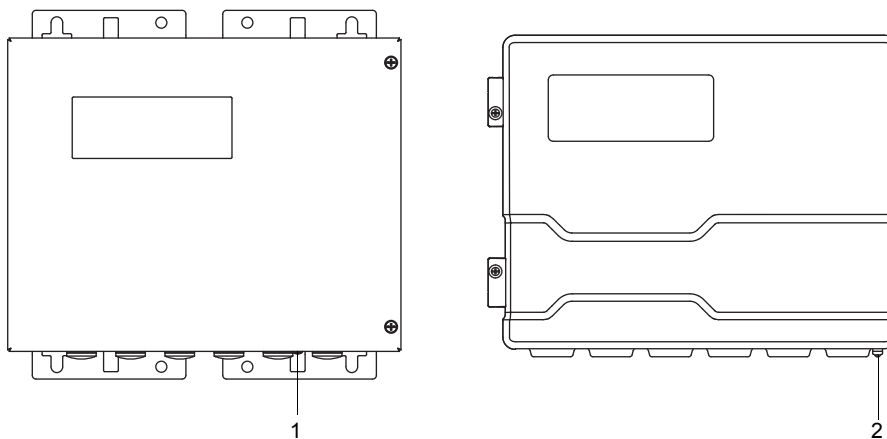

- 1 – equipotential bonding terminal on stainless steel housing
- 2 – equipotential bonding terminal on aluminum housing

• Connect the power cable to the transmitter, see section 7.2.1, Fig. 7.9 and Tab. 7.6.

Fig. 7.9: Connection of the power supply to the transmitter

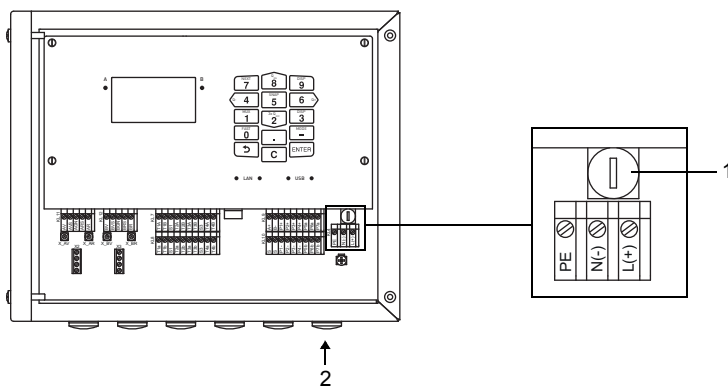

- 1 – fuse
- 2 – connection of the power supply

Tab. 7.6: Terminal assignment

terminal	connection AC	connection DC
PE	earth	earth
N(-)	neutral	-
L(+)	phase 100...230 V AC, 50...60 Hz	+
fuse	1 A, time-lag	1.6 A, time-lag

7.2.1 Cable connection

Transmitter with stainless steel housing

- Remove the blind plug to connect the cable to the transmitter.
- Prepare the cable with a cable gland. The used cable has to have a wire cross-section of 0.25...2.5 mm². The outer diameter of the cable where the ferrite nut is placed may not exceed 7.6 mm.
- Push the cable through cap nut, compression part, basic part and sealing ring (sealing ring: only for cable gland M20, not for cable gland 1/2 NPS).
- Insert the cable into the housing of the transmitter.
- Fix the cable gland by screwing the cap nut onto the basic part.
- Fix the transducer cable by tightening the cable gland with the ferrite nut.
- Connect the cable to the terminals of the transmitter.

Fig. 7.10: Cable gland for stainless steel housing

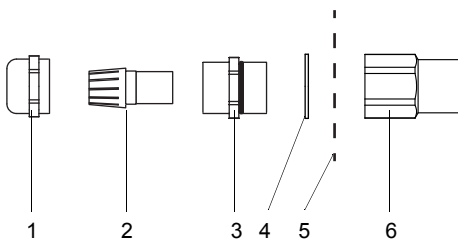

- 1 – cap nut
- 2 – compression part
- 3 – basic part
- 4 – sealing ring (only for cable gland M20, not for cable gland 1/2 NPS)
- 5 – housing wall
- 6 – ferrite nut

Transmitter with aluminum housing

- Remove the blind plug to connect the cable to the transmitter.
- Prepare the cable with a cable gland.
The used cable has to have a wire cross-section of 0.25...2.5 mm².
- Push the cable through the cap nut, compression part and basic part of the cable gland.
- Insert the cable into the housing of the transmitter.
- Screw the sealing ring side of the basic part into the transmitter housing.
- Fix the cable gland by screwing the cap nut onto the basic part.
- Connect the cable to the terminals of the transmitter.

Fig. 7.11: Cable gland for aluminum housing

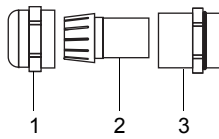

- 1 – cap nut
- 2 – compression part
- 3 – basic part

7.3 Outputs

Important!
The max. permissible voltage between the outputs and against PE is 60 V DC (permanent).

- Connect the output cable to the transmitter, see 7.2.1, Fig. 7.12 and Tab. 7.7.

Fig. 7.12: Connection of the outputs on the transmitter

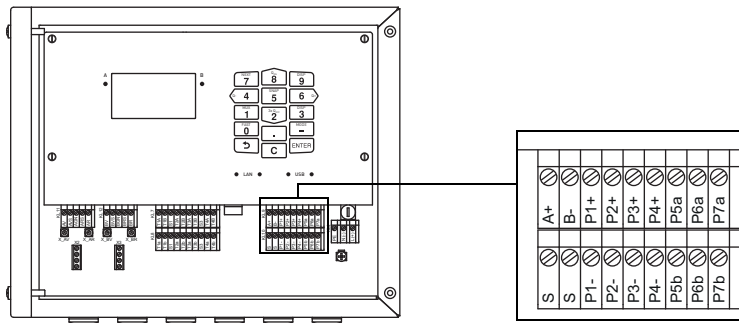







Tab. 7.7: Output circuits

output	transmitter		external circuit	remark
	internal circuit	connection		
active current output/HART	current output			
		Px+ Px-		$R_{ext} < 500 \Omega$
active current output/HART	HART			
		Px+ Px-		$U_{int} = 24 V$

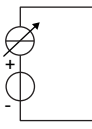
The number, type and the connections of the outputs depend on the order.

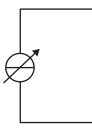
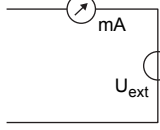
R_{ext} is the sum of all ohmic resistances in the circuit (e.g., resistance of the conductors, resistance of the ammeter/voltmeter).

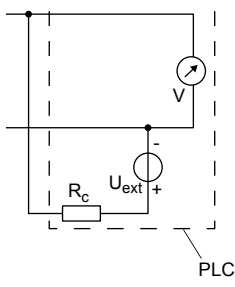
Tab. 7.7: Output circuits

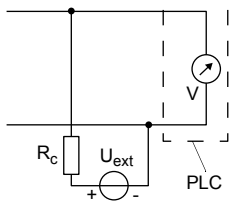
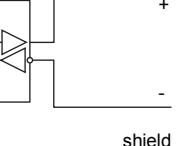
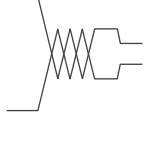
output	transmitter		external circuit	remark	
	internal circuit	connection			
switchable current output The switchable current output is switched to active or passive in the menu item <i>Special functions\Outputs</i> .	active current output			$R_{ext} < 350 \Omega$	
		Px+ Px-			
		passive current output			$U_{ext} = 8...30 V$ $U_{ext} > 0.021 A \cdot R_{ext} [\Omega] + 8 V$ example: $U_{ext} = 12 V$ $R_{ext} \leq 190 \Omega$
	Px+ Px-				
binary output (optorelay)	circuit 1			$U_{ext} \leq 26 V$ $I_c \leq 100 mA$ $R_c [k\Omega] = U_{ext} / I_c [mA]$	
		Pxa Pxb			
		circuit 2			
	Pxa Pxb				
RS485		A+ B- S		120 Ω termination resistor	

The number, type and the connections of the outputs depend on the order.

R_{ext} is the sum of all ohmic resistances in the circuit (e.g., resistance of the conductors, resistance of the ammeter/voltmeter).

7.4 Inputs

Important!
The max. permissible voltage between the inputs and against PE is 60 V DC (permanent).

Fig. 7.13: Connection of the transmitter inputs

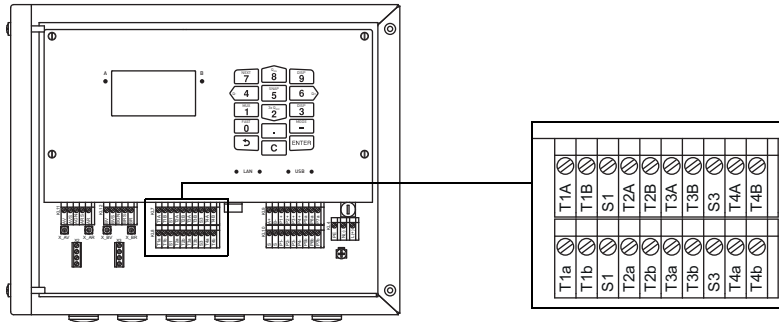

7.4.1 Current input

An active (self-powered) or a passive (external powered) current source can be connected to the current inputs of the transmitter.

Connection of an active current source

Important!
The terminals Txa and Txb must not be connected.

For the connection of the input cable to the transmitter see section 7.2.1, Fig. 7.13 and Tab. 7.8.

Tab. 7.8: Connection of an active current source

input	transmitter		external circuit	remark
	internal circuit	connection		
current input		TxA TxB TxB (not connected)		max. permanent overcurrent: 100 mA

If the polarity of the current source is inverted, only the sign of the measured current will change.

Connection of a passive current source

Important!
The terminals Txa and TxB must not be connected.

Important!
Observe the correct polarity in order to avoid damaging the current source. A permanent short circuit can lead to the destruction of the current input.

For the connection of the input cable to the transmitter see section 7.2.1, Fig. 7.13 and Tab. 7.9.

Tab. 7.9: Connection of a passive current source

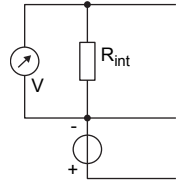
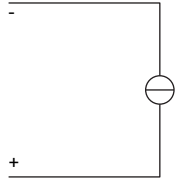
input	transmitter		external circuit	remark
	internal circuit	connection		
current input		TxA Txb (not connected) Txb		max. permanent overcurrent: 100 mA

At full load (20 mA), a voltage of 22.9 V DC is available for the supply of the passive current source.

7.5 Service interfaces

7.5.1 USB interface

The transmitter can be connected directly to the PC via USB interface.

- Connect the USB cable to the USB interface of the transmitter and the PC.

Fig. 7.14: Connection of the USB cable

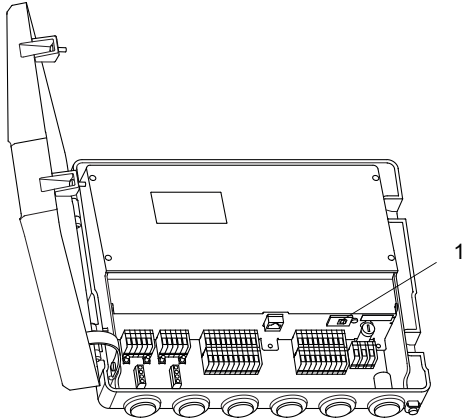

1 – USB interface

7.5.2 LAN interface

The transmitter can be connected to the PC or LAN via an LAN cable.

Transmitter with stainless steel housing

Fig. 7.15: Connection of the LAN cable

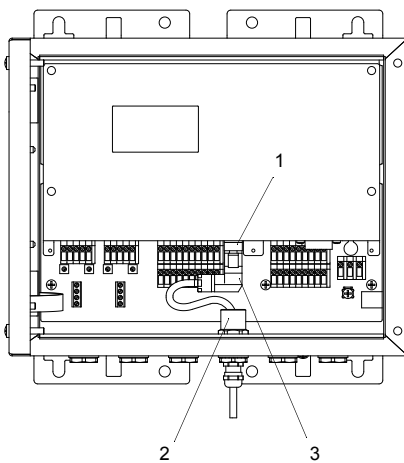

1 – LAN interface
2 – ferrite nut
3 – LAN connector

- Remove the blind plug to connect the cable to the transmitter.
- Open the cable gland of the LAN cable. The compression part remains in the cap nut.

Fig. 7.16: Cable gland

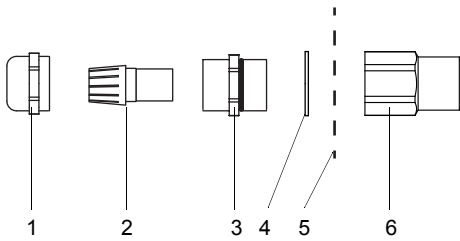

- 1 – cap nut
- 2 – compression part
- 3 – basic part
- 4 – sealing ring (only for cable gland M20, not for cable gland 1/2 NPS)
- 5 – housing wall
- 6 – ferrite nut

- Push the cable through cap nut, compression part, basic part and sealing ring (sealing ring: only for cable gland M20, not for cable gland 1/2 NPS).
- Insert the cable into the housing of the transmitter.
- Push the cable through the ferrite nut.
- Prepare the cable (see the documentation provided by the manufacturer).
- Install the connector (see the documentation provided by the manufacturer).
- Insert the connector into the LAN interface.
- Position the cable in the housing as shown in Fig. 7.15.
- Fix the cable gland by screwing the cap nut onto the basic part.
- Fix the transducer cable by tightening the cable gland with the ferrite nut.

Transmitter with aluminum housing

Fig. 7.17: Connection of the LAN cable

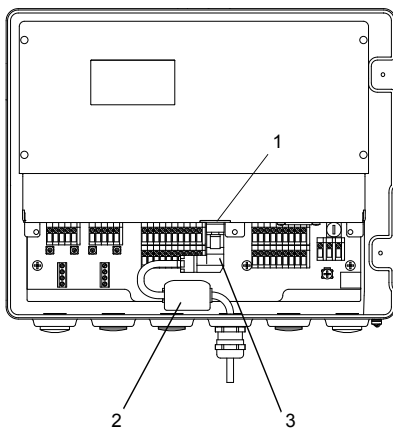

- 1 – LAN interface
- 2 – foldable ferrite core
- 3 – LAN connector

- Remove the blind plug to connect the cable to the transmitter.
- Open the cable gland of the LAN cable. The compression part remains in the cap nut.

Fig. 7.18: Cable gland

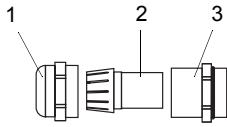

- 1 – cap nut
- 2 – compression part
- 3 – basic part

- Push the cable through the cap nut, compression part and basic part of the cable gland.
- Insert the cable into the housing of the transmitter.
- Prepare the cable (see the documentation provided by the manufacturer).
- Install the connector (see the documentation provided by the manufacturer).
- Insert the connector into the LAN interface.
- Fix the foldable ferrite core to the cable.
- Position the cable in the housing as shown in Fig. 7.17.
- Screw the sealing ring side of the basic part into the transmitter housing.
- Fix the cable gland by screwing the cap nut onto the basic part.

8 Start-up

Warning!



Installation, connection and start-up by unauthorized and unqualified personnel

This may result in personal or material damage or dangerous situations.

→ Any work on the transmitter has to be carried out by authorized and qualified personnel.

Danger!



Working in mines or cramped confines

Risk of intoxication and/or asphyxiation because of emerging gases, risk of injuries because of cramped conditions.

→ Wear the required personal protective equipment.

→ Observe the applicable rules.

Caution!



Safety and accident prevention regulations for electrical systems and equipment

Failure to observe these regulations may lead to severe injuries.

→ Observe the safety and accident prevention regulations for electrical systems and equipment.

Caution!



Warning of severe injuries from hot or cold components

Touching hot or cold components can lead to severe injuries (e.g., thermal damage).

→ Any mounting, installation or connection work has to be concluded.

→ Any work on the measuring point during the measurement is prohibited.

→ Observe the ambient conditions at the measuring point during installation.

→ Wear the required personal protective equipment.

→ Observe the applicable rules.

Notice!

The transmitter and transducers have to be checked to ensure proper condition and operational safety before each use. The transmitter housing must always be closed during operation. Observe that maintenance work must be concluded.

8.1 Start-up settings

When starting up the transmitter for the first time, the following settings are required:

- language
- time/date
- unit of measurement

These displays will only be indicated when the transmitter is switched on for the first time or after an initialization.

Language

The available transmitter languages are displayed.

- Select a language.
- Press ENTER.

The menus are displayed in the selected language.

Set time

The current time is displayed.

- Press ENTER to confirm the time or set the current time via the numeric field.
- Press ENTER.

Set date

The current date is displayed.

- Press ENTER to confirm the date or set the current date via the numeric field.
- Press ENTER.

Units of measurement

- Select `Metric` or `Imperial`.
- Press ENTER.

Region of Canada

- Select `Yes` if the transmitter is to be used in the region of Canada.
- Press ENTER.

This display will only be indicated if `Imperial` is selected.

8.2 Switching on

As soon as the transmitter is connected to the power supply, the menu is displayed in the adjusted language. The language can be changed.

Notice!

The parameters cannot be changed during the measurement. The measurement has to be stopped in order to change the parameters.

If the transmitter was switched off during the measurement, the message `Measurement started` will be displayed after connecting the transmitter to the power supply. The measurement is carried out with the parameters last set.

By pressing key  in the program branch `Measurement` it is possible either to stop the measurement or to display the current parameter settings.

8.3 Status indications

The operation state is indicated by LEDs.

Fig. 8.1: Command panel of the transmitter

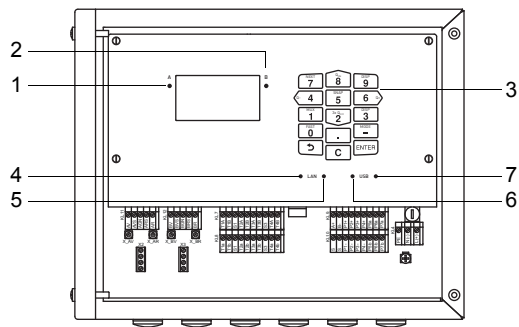

- 1 – LED (channel A)
- 2 – LED (channel B)
- 3 – keyboard
- 4 – LED LAN activity
- 5 – LED LAN mode
- 6 – LED USB device
- 7 – LED USB host (not used)

Tab. 8.1

LED (channel A)	Lights if the transmitter is in measuring mode and channel A is activated. red – invalid measurement green – valid measurement
LED (channel B)	Lights if the transmitter is in measuring mode and channel B is activated. red – invalid measurement green – valid measurement
LED LAN activity	Lights if the transmitter is connected to a network via USB cable. Flashes in case of data exchange on the network connection.
LED LAN mode	Lights if the data rate is 100 MBit/s otherwise it is 10 MBit/s.
LED USB device	Lights if the transmitter is connected to a PC via USB cable. Flashes in case of data exchange between PC and transmitter.

8.4 Program branches

The following schema shows the program branches. For a detailed overview of the menu structure see annex A.

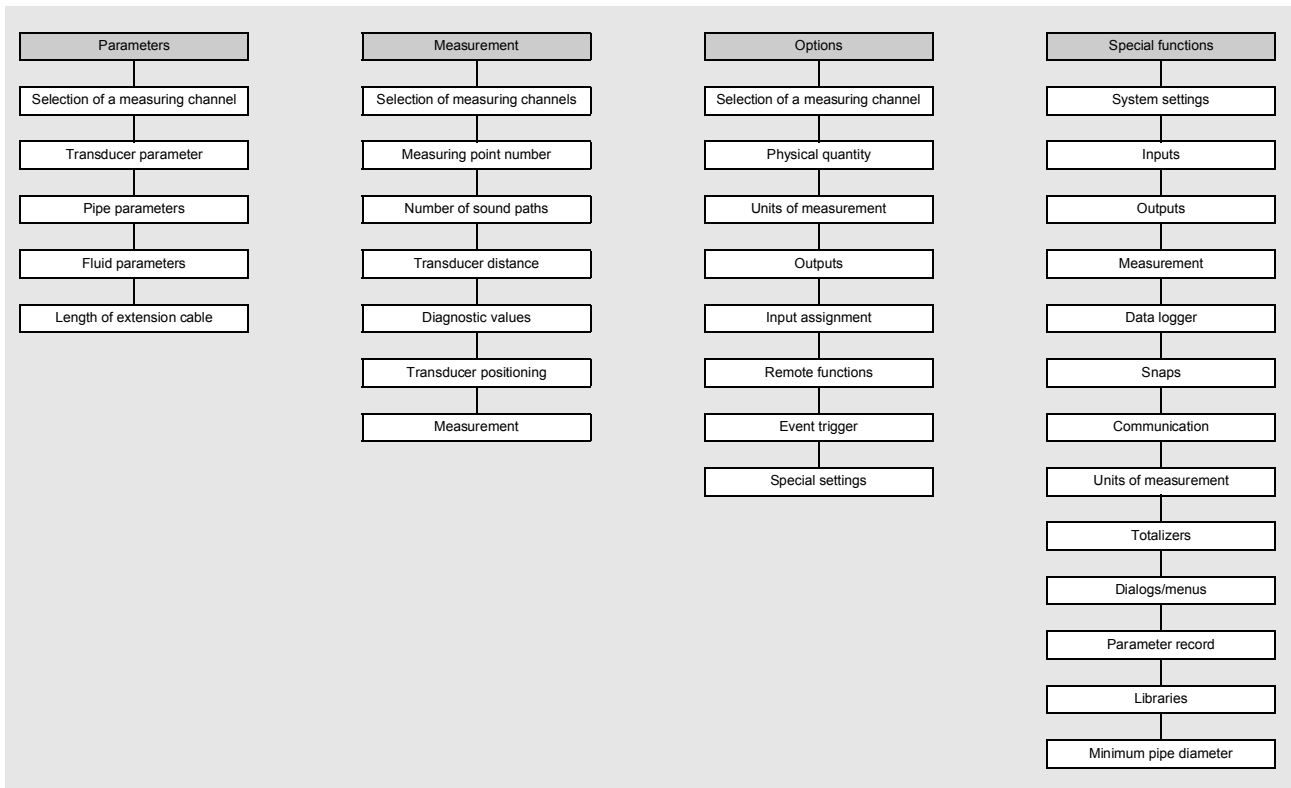

8.5 Language

Special functions\System settings\Language

The language of the transmitter can be selected:

- Select the menu item `Language`.
- Press ENTER.
- Select the desired language from the scroll list.
- Press ENTER.



Afterwards the menu will be displayed in the selected language. The selected language remains activated when the transmitter is switched off and on again.

The language can also be changed by entering a HotCode.

8.6 Initialization

During an initialization (INIT) of the transmitter, all settings are reset to the factory settings.

Proceed as follows to execute an initialization:

- When switching on a transmitter: keep  and C pressed.
- During the operation of the transmitter: press , C and ENTER simultaneously. Release only ENTER. Keep  and C pressed.

During an initialization it is tested whether the key lock is activated. If so, it has to be deactivated.

- Enter a 6-digit key lock code.
- Press ENTER.

If a measurement is currently running, it will be stopped.

It will be requested whether the initial settings are to be carried out.

Initial settings

If **Yes** is selected, the following setting dialogs will be displayed.

- Language
- Date/time
- Units of measurement
- Delete meas. values
- Delete snaps
- Delete user subst. (all customized materials and fluids which were stored after delivery will be deleted)
- Reset totalizers

The initialization can also be started with the HotCode **909000**.

8.7 Date and time

Special functions\System settings\Date/time

The transmitter has a battery-powered clock. Measured values are automatically stored with date and time.

- Select the menu item `Date/time`.

The adjusted time is displayed.

- Enter the current time via the numeric field.
- Press ENTER.

The adjusted date is displayed.

- Enter the current date via the numeric field.
- Press ENTER.

8.8 Information regarding the transmitter

Special functions\System settings\Transmitter info

- Select the menu item `Transmitter info`.
- Press ENTER.
- Press `2` or `8` to scroll through the list.
- Press `5` to return to the menu item `System settings`.

The following information regarding the transmitter is displayed:

display	description
Serial number	type and serial number of the transmitter
Firmware version	version number of the installed firmware
Firmware date	creation date of the installed firmware
Production date	manufacturing date of the transmitter
MAC address	MAC address of the transmitter
Service TCP port	TCP port of the transmitter

9 Measurement

Caution!



Warning of severe injuries from hot or cold components

Touching hot or cold components can lead to severe injuries (e.g., thermal damage).

- Any mounting, installation or connection work has to be concluded.
- Any work on the measuring point during the measurement is prohibited.
- Observe the ambient conditions at the measuring point during installation.
- Wear the required personal protective equipment.
- Observe the applicable rules.

9.1 Parameter input

Notice!

All settings changed in this program branch will be stored at the beginning of the measurement.

Notice!

Avoid a simultaneous parameter entry via the keyboard and the USB, LAN or process interface. The parameter records received via these interfaces will overwrite the current transmitter parameterization.

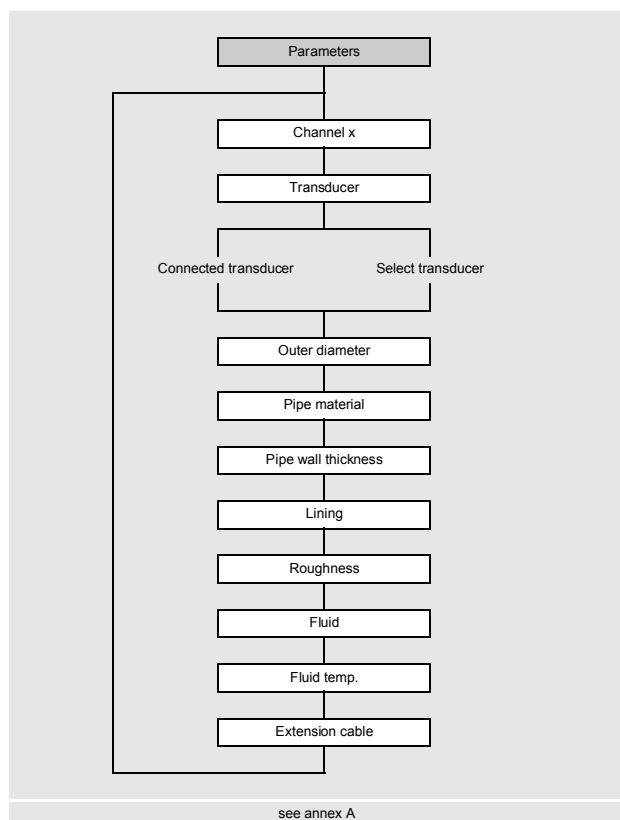

The pipe and fluid parameters are entered for the selected measuring point. The parameter ranges are limited by the technical characteristics of the transducers and the transmitter.

- Select the program branch `Parameters`.
- Press ENTER.

`Parameters\Channel A`

- Select the channel for which the parameters are to be entered (here: `Channel A`).
- Press ENTER.

The display will not be indicated if the transmitter has only one measuring channel.

9.1.1 Transducer selection

Notice!

The transducer is selected in dependence of the inner pipe diameter (= outer pipe diameter - 2 × pipe wall thickness), see technical specification.

```
Parameters\Clamp-on transducer CDP2E52
```

- The transducer (here: CDP2E52) connected to the transmitter is displayed.
- Press ENTER.

This display will only be indicated if transducers and transducer module are connected to the transmitter.

```
Parameters\Connected transd.
```

The parameters can also be entered without connected transducers or transducer module.

- Select Connected transd.
- Press ENTER.

The display Transducer not found will be indicated if neither transducers nor transducer module are connected.

- Press ENTER.

```
Parameters>Select transducer
```

- Select Select transducer to use the standard transducer stored in the transmitter.
- Select the transducer.
- Press ENTER.

This display will only be indicated if the transducers and the transducer module are connected to the transmitter.

Notice!

If a standard transducer is selected, no transducer-specific calibration values are considered. A higher uncertainty has to be expected.

9.1.2 Input of pipe parameters

Outer pipe diameter

```
Parameters\Outer diameter
```

- Enter the outer pipe diameter.
- Press ENTER.

It is possible to enter the pipe circumference instead of the outer pipe diameter.

Pipe circumference

```
Parameters\Pipe circumference
```

- Activate the input of the pipe circumference.
- Press key in the menu item Outer diameter. The menu item Pipe circumference will be displayed.
- Enter the pipe circumference.
- Press ENTER.

If the outer pipe diameter is to be entered, press key . The menu item Outer diameter is displayed.

Pipe material

Parameters\Pipe material

The pipe material has to be selected to be able to determine the corresponding sound speed.

The sound speeds for the materials in the scroll list are stored in the transmitter.

- Select the pipe material.
- Press ENTER.
- If the material is not in the scroll list, select `Other material`.
- Press ENTER.

Sound speed of the pipe material

Parameters\Pipe material\Other material\c material

- Enter the sound speed of the pipe material.

Notice!

There are 2 sound speeds for pipe materials, the longitudinal and the transversal one. Enter the sound speed which is nearer to 2500 m/s.

- Press ENTER.
- Select `Transverse wave` or `Longitudinal wave`.
- Press ENTER.

These displays will only be indicated if `Other material` is selected.

For the sound speed of some materials, see annex C.

Roughness of the pipe material

Parameters\Pipe material\Other material\Roughness

The flow profile of the fluid is influenced by the roughness of the inner pipe wall.

The roughness is used for the calculation of the profile correction factor.

In most cases, the pipe roughness cannot be exactly determined and must therefore be estimated.

- Press ENTER if the pipe has a lining. The pipe roughness of the lining is included into the calculation.
- Enter the roughness of the pipe material in case the pipe has no lining. Press ENTER.

This display will only be indicated if `Other material` is selected.

For the roughness of some materials, see annex C.

Wall thickness

Parameters\Pipe wall thickness

- Enter the pipe wall thickness.
- Press ENTER.

Lining

Parameters\Lining

- Select `Yes` if the pipe has a lining. Select `No` if the pipe has no lining.
- Press ENTER.

Lining material

Parameters\Lining material

- Select the lining material.
- Press ENTER.
- If the lining material is not included in the scroll list, select `Other material`.
- Press ENTER.

This display will only be indicated if `Yes` is selected in the menu item `Lining`.

Sound speed of the lining material

Parameters\Lining material\Other material\c material

- Enter the sound speed of the lining material.

Notice!

For pipe materials there are 2 sound speeds, the longitudinal and the transversal one. Enter the sound speed which is nearer to 2500 m/s.

- Press ENTER.
- Select `Transverse wave` or `Longitudinal wave`.
- Press ENTER.

These displays will only be indicated if `Other material` is selected.

Roughness of the lining material

Parameters\Lining material\Other material\Roughness

The flow profile of the fluid is influenced by the roughness of the inner pipe wall.

The roughness is used for the calculation of the profile correction factor.

In most cases, the pipe roughness cannot be exactly determined and must therefore be estimated.

- Enter the roughness of the lining material.
- Press ENTER.

This display will only be indicated if `Other material` is selected.

Lining thickness

Parameters\Lining thickness

- Enter the thickness of the lining.
- Press ENTER.

This display will only be indicated if `Yes` is selected in the menu item `Lining`.

Roughness

Parameters\Roughness

The flow profile of the fluid is influenced by the roughness of the inner pipe wall.

The roughness is used for the calculation of the profile correction factor.

In most cases, the pipe roughness cannot be exactly determined and must therefore be estimated.

- If `Automatic` is selected, the roughness values stored in the transmitter are used.
- If `Customized` is selected, a roughness value has to be entered.
- Press ENTER.

This display will not be indicated if `Other material` is selected in the menu item `Pipe material` or `Lining material`.

9.1.3 Input of fluid parameters

Fluid temperature

Parameters\Fluid temp.

The fluid temperature is used:

- at the beginning of the measurement for the interpolation of the sound speed and therefore for the calculation of the recommended transducer distance
- during the measurement for the interpolation of the density and the viscosity of the fluid

This value is only used, if the temperature is not measured. The value has to be within the operating temperature range of the transducers.

- Enter the fluid temperature. In case of a temperature range, enter the average fluid temperature.

Notice!

If the relation between the sound speed and the temperature is not linear, see the sound speed-temperature curve.

- Press ENTER.

Fluid pressure

Parameters\Fluid pressure

The fluid pressure is used for the interpolation of the sound speed.

- Enter the fluid pressure.
- Press ENTER.

9.1.4 Other parameters

Extension cable

Parameters\Extension cable

In case the transducer cable is extended (e.g., between junction box and transmitter), enter the length of the extension cable.

- Select the menu item `Extension cable` in the program branch `Parameters`.
- Enter the length of the extension cable.
- Press ENTER.

9.2 Measurement settings

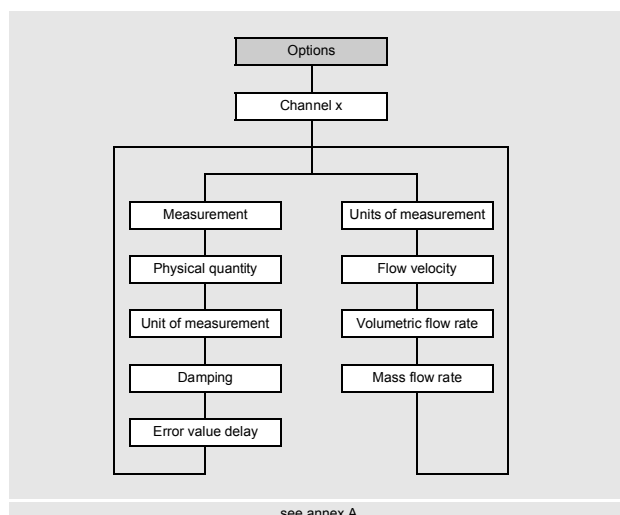

- Select the program branch `Options`.
- Press ENTER.

Options\Channel A

- Select the channel for which a physical quantity has to be entered (here: `Channel A`)
 - Press ENTER.
- This display will not be indicated if the transmitter has only one measuring channel.
- Select the menu item `Measurement`.
 - Press ENTER.

9.2.1 Selection of the physical quantity

Options\Channel A\Measurement\Physical quantity

- Select the menu item Physical quantity.
- Press ENTER.

9.2.2 Selection of the unit of measurement

Options\Channel A\Physical quantity\Volumetric flow rate

For the selected physical quantity (except sound speed), a scroll list with the available units of measurement is displayed. The unit of measurement which was selected previously is displayed first.

- Select the unit of measurement of the physical quantity.
- Press ENTER.

Notice!

If the physical quantity or the unit of measurement is changed, the settings of the outputs will have to be checked.

9.2.3 Input of the damping factor

Options\Channel A\Measurement\Damping

Each displayed measured value is a floating average of the last x seconds, with x being the damping factor. If 0 s is entered as damping factor, no average is calculated.

The value of 10 s is appropriate for normal flow conditions. If the values fluctuate strongly, caused by a higher dynamic flow, a higher damping factor can be very useful.

- Enter the damping factor.
- Press ENTER.

9.2.4 Input of the error delay

Options\Channel A\Measurement>Error value delay

The error delay is the time interval after which the error value is transmitted to the output.

This display will only be indicated if the list item Edit is selected in the menu item Special functions\Dialogs/Menus>Error value delay.

If the error delay is not entered, the damping factor will be used.

- Enter a value for the error delay.
- Press ENTER.

9.2.5 Configuration of an output

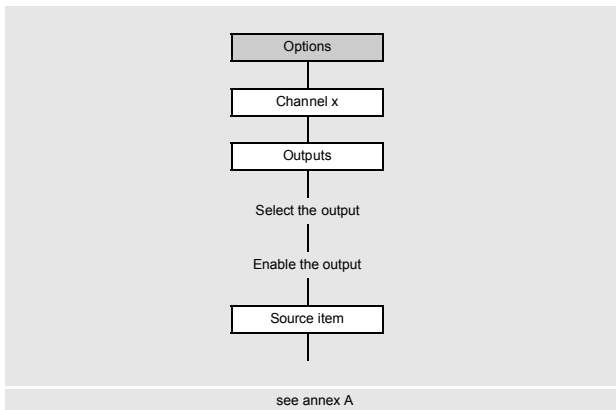

If the transmitter is equipped with outputs, they have to be configured. In principle, the measured value, the status value or an event value can be transmitted via the different outputs.

In the following, the configuration of an analog outputs is described.

- Select the program branch `Options`.
- Press ENTER.

Selection of the measuring channel

```
Options\Channel A
```

- Select the channel (here: `Channel A`).
- Press ENTER.

This display will not be indicated if the transmitter has only one measuring channel.

Assignment of an output

- Select the menu item `Outputs`.
- Press ENTER.

```
Options\Channel A\Outputs\Current I1(--)
```

- Select an output to be assigned to the channel (here: `Current I1(--)`).
- Press ENTER.

The scroll list contains all available outputs of the transmitter:

```
- Current Ix (--)
- Binary Bx (--)
```

If the output has already been assigned to a channel, it is displayed as follows: `Current I1 (A)`.

```
Options\Channel A\Outputs\Current I1\I1 Enable
```

- Select `Yes` to change the settings for an already assigned output or to assign a new output.
- Select `No` to cancel the assignment and to return to the previous menu item.
- Press ENTER.

Assignment of a source item

One source item has to be assigned to each selected output.

```
Options\Channel A\Outputs\...\Source item
```

- Select a source item whose measured value, status value or event value is to be transmitted via the output.
- Press ENTER.

Tab. 9.1: Configuration of the outputs

source item	list item	output
Flow quantities	Flow velocity Volumetric flow rate Mass flow rate	flow velocity volumetric flow rate mass flow rate
Totalizers	Volume (+) Volume (-) Volume (Δ) Mass (+) Mass (-) Mass (Δ)	totalizer for the volumetric flow rate in positive flow direction totalizer for the volumetric flow rate in negative flow direction difference of the totalizers for the positive and negative flow direction totalizer for the mass flow rate in positive flow direction totalizer for the mass flow rate in negative flow direction difference of the totalizers for the positive and negative flow direction
Pulse	Pulse V Pulse +V Pulse -V Pulse m Pulse +m Pulse -m	pulse without sign consideration of the volume flow rate pulse for positive measured values of the volumetric flow rate pulse for negative measured values for the volumetric flow rate pulse without sign consideration of the mass flow rate pulse for the positive measured values of the mass flow rate pulse for the negative measured values of the mas flow rate
Event trigger	R1 R2 R3 R4	limit message (Event trigger R1) limit message (Event trigger R2) limit message (Event trigger R3) limit message (Event trigger R4)
Diagnostic values	Amplitude Quality SNR SCNR VariAmp VariTime Amplification PIG detection	signal amplitude signal quality ratio useful signal/noise signal ratio of useful signal and correlated noise signal amplitude fluctuation transit time fluctuation amplification, important to receive a useful signal signalizes whether a pig is detected This display will only be indicated if PIG detection is activated.
Miscellaneous	Custom. Input 1 Custom. Input 2 Custom. Input 3 Custom. Input 4	measured values of input quantities (e.g., temperature, density) which are not used for calculation In the menu item Options\Assign inputs it is possible to assign configured inputs to customized inputs.
Sound speed	Sound speed Sound speed (Δ)	sound speed difference of the measured sound speed and the sound speed calculated from the fluid data

Tab. 9.2: Output of measured values, status values or event values

	source item	measured value		event value
		value	status	
physical quantities	Flow quantities	x	x	
	Totalizers	x	x	
	Fluid properties	x	x	
	Miscellaneous (Custom. Input 1...4)	x	x	
	Sound speed	x	x	
	Pulse	x	x	
	Diagnostic values (except PIG detection)	x		
events	Diagnostic values\ PIG detection			x
	Event trigger			x

9.2.5.1 Output of a measured value

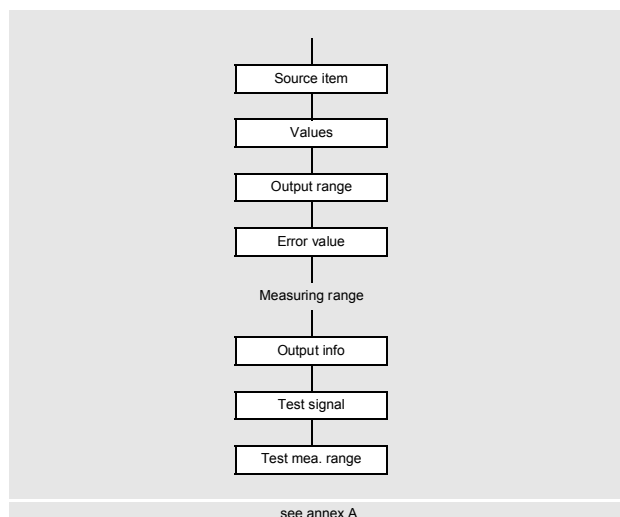

- Select the list item `Options\Outputs\...\Values`.
- Press ENTER.

Output range

```
Options\Channel A\Outputs\...\Output range
```

- Select a list item.
 - 4...20 mA
 - Other range

- Press ENTER.

If `Other range` is selected, enter the values `Output MIN` and `Output MAX`.

The output range has to have > 10 % of the max. output value (`Output MAX`). An error message will be displayed if the output range is smaller. The next possible value will be displayed.

Error output

```
Options\Channel A\Outputs\...\Error value
```

An error value which is output if the source item cannot be measured, can be defined.

- Select a list item for the error output.
- Press ENTER.
- If `Other value` is selected, enter an error value. The value has to be within the output range.
- Press ENTER.

Example

source item: volumetric flow rate
 output: current output
 output range: 4...20 mA

error delay: $t_d > 0$

The volumetric flow rate cannot be measured during the time interval $t_0 \dots t_1$. The error value will be output.

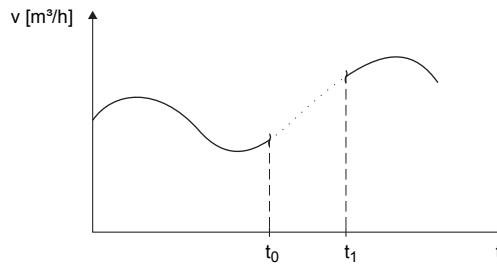

Tab. 9.3: Examples for the error output (output range: 4...20 mA)

list item	output signal
4.0 mA	
Last value	
20.0 mA	
Other value error value = 3.5 mA	

Measuring range

The sign of the measured value and the measuring range are determined.

```
Options\Channel A\Outputs\...\Measured values\Absolute value
```

- Select `Sign` if the sign of the measured values is to be considered for the output.
- Select `Absolute value` if the sign of the measured values is not to be considered for the output.

```
Options\Channel A\Outputs\...\Start of meas. range
```

- Enter the lowest expected measured value. The unit of measurement of the source item will be displayed.
- `Start of meas. range` is the value assigned to the value `Output MIN` of the output range.

```
Options\Channel A\Outputs\...\End of meas. range
```

- Enter the highest expected measured value. The unit of measurement of the source item will be displayed.
- `End of meas. range` is the value assigned to the value `Output MAX` of the output range.

Terminal assignment

```
Options\Channel A\Outputs\...\Output info
```

The terminals for the connection of the output are displayed.

By pressing key `2` or `8` further information is displayed.

- Press ENTER.

Output function test

The function of the output can now be tested.

- Connect an external measuring instrument to the terminals of the output.

```
Options\Channel A\Outputs\...\Test signal
```

- Select `Yes` to test the output. Select `No` to display the next menu item.
- Press ENTER.

```
Options\Channel A\Outputs\...\Enter test value
```

- Enter a test value. It has to be within the output range.
- Press ENTER.

If the external measuring instrument displays the entered value, the output functions correctly.

- Select `Repeat` to repeat the test, `Finish` to display the next menu item.
- Press ENTER.

```
Options\Channel A\Outputs\...\Test mea. range
```

- Select `Yes` to test the assignment of the measured value to the output signal. Select `No` to display the next menu item.
- Press ENTER.

Options\Channel A\Outputs\...\Enter test value

- Enter a test value for the selected physical quantity. It has to be within the output range.
- Press ENTER.

If the external measuring instrument displays the entered value, the output functions correctly.

- Select Repeat to repeat the test. Select Finish to display the next menu item.
- Press ENTER.

9.2.5.2 Output of a status value

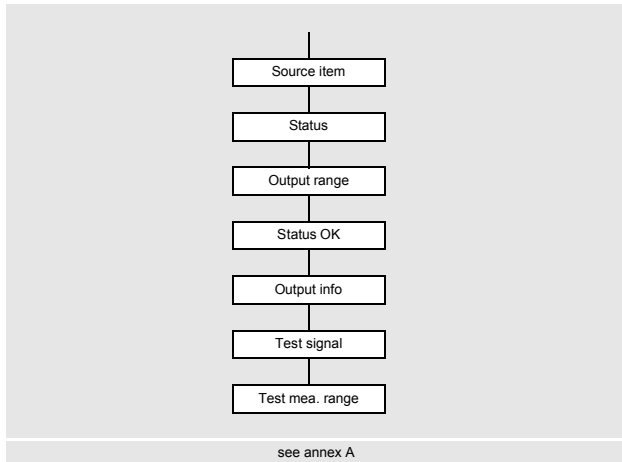

- Select the list item Options\Outputs\...\Status.
- Press ENTER.

Output range

Options\Channel A\Outputs\...\Output range

- Select a list item.
 - 4...20 mA
 - Other range
- Press ENTER.

If Other range is selected, enter the values Output MIN and Output MAX.

The output range has to have > 10 % of the max. output value (Output MAX). An error message will be displayed if the output range is smaller. The next possible value will be displayed.

Status OK

The status of the output signal is defined which is to be output if the measured value is valid.

Options\Channel A\Outputs\...\Status OK

- Select in the scroll list the value for Status OK.
- Press ENTER.

Terminal assignment

Options\Channel A\Outputs\...\Output info

The terminals for the connection of the output are displayed.

By pressing key 2 or 8 further information is displayed.

- Press ENTER.

Output function test

The function of the output can now be tested.

- Connect an external measuring instrument to the terminals of the output.

```
Options\Channel A\Outputs\...\Test signal
```

- Select `Yes` to test the output. Select `No` to display the next menu item.
- Press `ENTER`.

```
Options\Channel A\Outputs\...\Enter test value
```

- Enter a test value. It has to be within the output range.
- Press `ENTER`.

If the external measuring instrument displays the entered value, the output functions correctly.

- Select `Repeat` to repeat the test, `Finish` to display the next menu item.
- Press `ENTER`.

```
Options\Channel A\Outputs\...\Test mea. range
```

- Select `Yes` to test the status of the output signal. Select `No` to display the next menu item.
- Press `ENTER`.

```
Options\Channel A\Outputs\...\Enter test value
```

- Select in the scroll list `Status OK` or `Status error`.
- Press `ENTER`.

If the external measuring instrument displays the value (min. output value for `Status error`, max output for `Status OK`), the output functions correctly.

- Select `Repeat` to repeat the test, `Finish` to display the next menu item.
- Press `ENTER`.

9.2.5.3 Output of an event value**Output range**

```
Options\Channel A\Outputs\...\Output range
```

- Select a list item.
 - 4...20 mA
 - Other range

- Press `ENTER`.

If `Other range` is selected, enter the values `Output MIN` and `Output MAX`.

The output range has to have > 10 % of the max. output value (`Output MAX`). An error message will be displayed if the output range is smaller. The next possible value will be displayed.

Idle state

The status of the output signal which is to be output if no event occurs is defined.

```
Options\Channel A\Outputs\...\Idle state
```

- Select the value for the idle state.
- Press `ENTER`.

Terminal assignment

```
Options\Channel A\Outputs\...\Output info
```

The terminals for the connection of the output are displayed.

By pressing key **2** or **8** further information is displayed.

- Press ENTER.

Output function test

The function of the output can now be tested.

- Connect an external measuring instrument to the terminals of the output.

```
Options\Channel A\Outputs\...\Test signal
```

- Select **Yes** to test the output. Select **No** to display the next menu item.
- Press ENTER.

```
Options\Channel A\Outputs\...\Enter test value
```

- Enter a test value. It has to be within the output range.
- Press ENTER.

If the external measuring instrument displays the entered value, the output functions correctly.

- Select **Repeat** to repeat the test, **Finish** to display the next menu item.
- Press ENTER.

```
Options\Channel A\Outputs\...\Test mea. range
```

- Select **Yes** to test the status of the output signal. Select **No** to display the next menu item.
- Press ENTER.

```
Outputs\...\Enter test value
```

- Enter a test value for the selected physical quantity. It has to be within the output range.
- Press ENTER.

If the external measuring instrument displays the entered value, the output functions correctly.

- Select **Repeat** to repeat the test. Select **Finish** to display the next menu item.
- Press ENTER.

9.2.5.4 Switchable current output

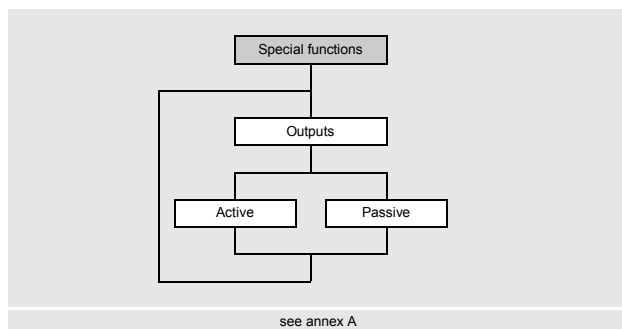

- Select the menu item **Outputs** in the program branch **Special functions**.
- Press ENTER.

```
Special functions\Outputs
```

- Select **Active** if the current output is to be switched to active. Select **Passive** if the current output is to be switched to passive.
- Press ENTER.

9.3 Start of the measurement

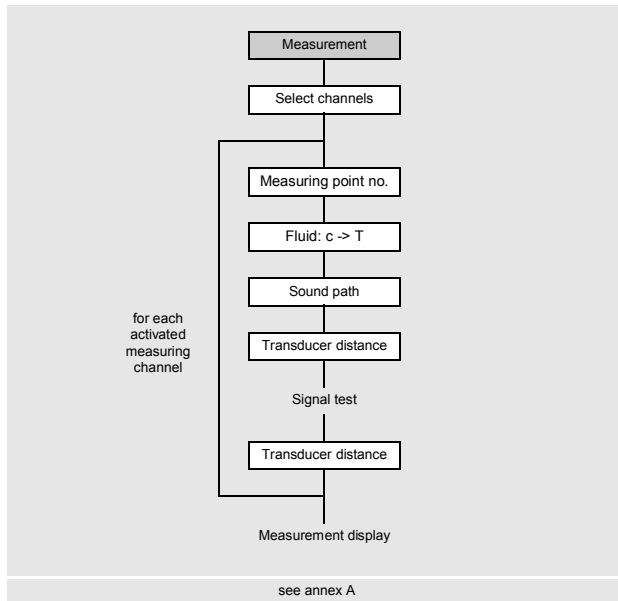

- Select the program branch `Measurement`.
- Press ENTER.

Activation of the channels

```
Measurement\Select channels
```

The channels for the measurement can be activated and deactivated.

: the channel is activated

: the channel is deactivated

: the channel cannot be activated

This display will not be indicated if the transmitter has only one measuring channel.

- Select a channel with key `<4>` or `<6>`.

Notice!

Pass the program branch `Parameters` in its entirety if is displayed for all channels.

- Press key `<2>` or `<8>` to activate or deactivate the channel.

If the parameters in the program branch `Parameters` are not valid or incomplete, the error message `Invalid parameters` will be displayed.

A deactivated channel will be ignored during the measurement.

Input of the measuring point number

```
Measurement\Measuring point no.
```

- Enter the number of the measuring point.
- Press ENTER.

For the activation of the text input see `Special functions\Dialogs\Menus\Measuring point no..`

Calibration of the temperature calculation from the sound speed

The transmitter is able to calculate the temperature from the sound speed of the fluid during the measurement. The accuracy of the measured sound speed of the fluid depends on the accuracy of the entered parameters or on the mounting of the transducers.

If the temperature has to be calculated from the sound speed of the fluid during the measurement, a calibration based on the actual fluid temperature is carried out when starting the measurement. It has to be measured and entered in the transmitter. From the difference of the entered fluid temperature and the sound speed of the calculated fluid temperature an offset is determined and stored in the transmitter.

If the measurement is started the first time with activated calculation of the fluid temperature from the sound speed, the transmitter does not have stored any offset yet. The fluid temperature has to be entered.

```
Measurement\Fluid temp.
```

- Enter the calculated fluid temperature.
- Press ENTER.

This display will only be indicated if the calculation of the temperature offset is enabled in the menu item `Options\Special settings\Fluid: c -> T.`

Notice!

After starting the measurement the determination of the offset can last up to 2 minutes (100 sound speed measurements are averaged).

If an offset for the calculation of the temperature from a previous measurement is stored in the transmitter, when starting a measurement, it will be requested whether a calibration is to be carried out. The currently stored offset will be displayed (here: 2.7 K).

```
Measurement\Fluid: c -> T Δ2.7K
```

- Select *Keep calibration* if the currently stored offset is to be used.
- Press ENTER.
- Select *New calibration* if the offset has to be redefined.
- Press ENTER.

```
Measurement\Fluid temp.
```

- Enter the calculated fluid temperature.
- Press ENTER.

This display will only be indicated if *New calibration* is selected.

Input of the sound path number

```
Measurement\Sound path
```

- Enter the number of sound paths.
- Press ENTER.

Adjustment of the transducer distance

```
Measurement\Transducer distance
```

The recommended transducer distance will be displayed. The transducer distance is measured between the inner edges of the transducers. In case of a measurement in diagonal arrangement on very small pipes, a negative transducer distance is possible.

Notice!

The accuracy of the recommended transducer distance depends on the accuracy of the entered pipe and fluid parameters.

- Mount the transducers on the pipe and adjust the transducer distance.
- Press ENTER.

The diagnostics window is displayed.

Fine adjustment of the transducer distance

The amplitude of the received signal is displayed by bar graph AMP.

The bar graph SCNR shows the ratio of the useful signal an the correlated noise signal.

- Shift one of the transducers slightly within the range of the recommended transducer distance until the bar graph reaches the max. length.

Fig. 9.1: Diagnostics window

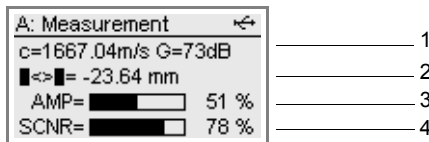

- 1 – measured sound speed of the fluid and signal amplification
- 2 – recommended transducer distance
- 3 – amplitude (bar graph)
- 4 – SCNR value (bar graph)

Tab. 9.4: Diagnostic values

	display ¹	explanation
key <input type="text" value="9"/> (1 in Fig. 9.1)	c, G	measured sound speed of the fluid and signal amplification
	SCNR	ratio of useful signal and correlated noise signal
	SNR	ratio useful signal/noise signal
	Q	signal quality bar graph has to reach max. length By pressing <input type="text" value="8"/> it is possible to display the numeric value instead of the bar graph.
	GAIN	signal amplification If the current value of the amplification is higher than the max. amplification, the current value is displayed with →FAIL!.
key <input type="text" value="3"/> (2 in Fig. 9.1)	■<>■	recommended transducer distance
	SCNR	ratio of useful signal and correlated noise signal
	SNR	ratio useful signal/noise signal
	Q	signal quality bar graph has to reach max. length By pressing <input type="text" value="2"/> it is possible to display the numeric value instead of the bar graph.

¹ In order to avoid doubling, a value already be displayed in one of these lines will be ignored in the other.

- In case of large deviations of the diagnostic values, check if the entered parameters are correct or repeat the measurement at a different point on the pipe.
- Press ENTER.

Tab. 9.5: Recommended diagnostic limits

good measurement	measurement at limit	measurement not possible
SCNR > 30 dB (> 50 %)	20 dB ≤ SCNR ≤ 30 dB (0 % < SCNR ≤ 50 %)	SCNR < 20 dB (= 0 %)
SNR > 15 dB	0 dB ≤ SNR ≤ 15 dB	SNR < 0 dB
GAIN < 98 dB	98 dB ≤ GAIN ≤ 113 dB	GAIN > 113 dB

Input of the transducer distance

Measurement\Transducer distance

After precise transducer positioning, the recommended transducer distance is displayed in brackets again. The optimum transducer distance is calculated on the basis of the measured sound speed. It is therefore a better approximation than the first recommended value which had been calculated on the basis of the sound speed range entered in the program branch *Parameters*.

- Measure the transducer distance.
- Enter the measured transducer distance. Make sure, the standard values for signal optimization within the total sound speed range to be measured must not be exceeded.
- Press ENTER.

The measurement is started. The measured values are displayed.

Tab. 9.6: Standard values for signal optimization

transducer frequency (3rd character of the technical type)	difference between the optimum and the entered transducer distance [mm]	
	shear wave transducer	Lamb wave transducer
F	-	-60...+120
G	20	-45...+90
H	-	-30...+60
K	15	-20...+40
M	10	-10...+20
P	8	-5...+10
Q	6	-3...+5
S	3	-

9.4 Display of measured values

The measured values are displayed during the measurement as follows:

Fig. 9.2: Display of measured values

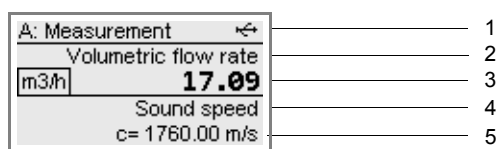

- 1 – channel, program branch, status indicators
- 2 – physical quantity
- 3 – unit of measurement and measured value
- 4 – further measured values
- 5 – further measured values

By pressing **[3]** or **[9]**, additional physical quantities can be displayed during the measurement, see .

- Press **[3]** to display the measured values in line 5. The designation of the physical quantity is displayed in line 4 by pressing **[9]** for several seconds.
- Press **[9]** to display the measured values in line 4. The designation of the physical quantity is displayed in line 5 by pressing **[3]** for several seconds.

toggling between the channels

If the measurement is started on several channels, the display of the measured values can be adapted as follows:

AutoMux mode

If the AutoMux mode is activated, the measured values of all activated channels (measuring and calculation channels) are displayed consecutively. The next active channel is selected after 3 s. The toggle time can be changed in the menu item Special functions\Dialogs\Menus\Toggle time.

HumanMux mode

The measured values of one channel are displayed in the HumanMux mode. The measurement on the other channels continues.

- Press key 7 to display the next activated channel. The measured values for the selected channel are displayed. Each measurement starts in AutoMux mode. Press key 1 to toggle between the modes.

Status line

Important information of the running measurement is summarized in the status line. The quality and precision of the measurement can be evaluated. Press key 9 during the measurement to scroll to the status line.

Fig. 9.3: Display of the status line

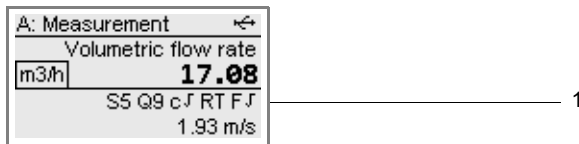

1 – status line

Tab. 9.7: Description of the status line

	value	explanation
S	0 ... 9	signal amplitude < 5 % ... ≥ 90 % values ≥ 3 are sufficient for the measurement
Q	0 ... 9	signal quality < 5 % ... ≥ 90 %
c	√ ↑ ↓ ?	sound speed comparison of the measured and the expected sound speed of the fluid The expected sound speed is calculated from the fluid parameters. The expected sound speed is calculated from the fluid parameters. OK, is equal to the expected value > 20 % of the expected value < 20 % of the expected value unknown, cannot be measured
R	T L ↑ ?	flow profile information about the flow profile based on the Reynolds number fully turbulent flow profile fully laminar flow profile transition range between laminar and turbulent flow unknown, cannot be calculated

Tab. 9.7: Description of the status line

	value	explanation
F		flow velocity comparison of the measured flow velocity with the flow limits of the system
	√	OK, the flow velocity is not within the critical range
	↑	the flow velocity is higher than the current limit
	↓	the flow velocity is lower than the current cut-off flow
	0	the flow velocity is within the limit range of the measuring method
	?	unknown, cannot be measured

Transducer distance

By pressing key during the measurement, it is possible to scroll to the display of the transducer distance.

Fig. 9.4: Display of the transducer distance

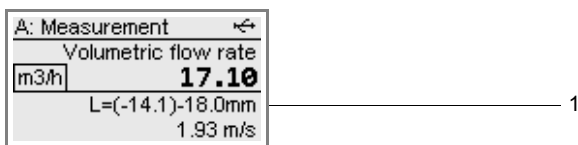

1 – transducer distance

The recommended transducer distance will be displayed in brackets, the measured transducer distance will be displayed afterwards. The recommended transducer distance might change during the measurement (e.g., due to temperature fluctuations). A deviation from the recommended transducer distance will be compensated internally.

Notice!
Never change the transducer distance during the measurement.

Transducer temperature

In the `SuperUser` and `SuperUser ext.` it is possible to display the transducer temperature during the measurement. By pressing key during the measurement, it is possible to scroll to the transducer temperature display.

Fig. 9.5: Display of the transducer temperature

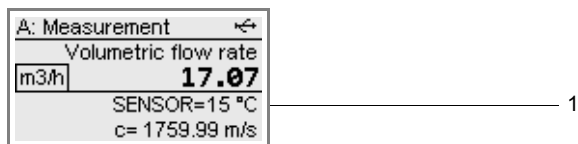

1 – transducer temperature

Notice!
If the compliance of the specified transducer temperature has to be monitored, an event trigger can be set on the temperature value.

9.5 Display of parameters

The parameters can be displayed during the measurement.

- Press key  during the measurement.

The following display appears:

Fig. 9.6: Scroll list in the program branch `Measurement`

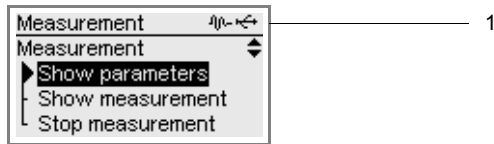

1 – status indication

The measurement is running in the background. The symbol  is displayed in the status indication.

```
Measurement\Show parameters
```

- Select `Show parameters` in the scroll list.
- Press ENTER.
- The program branch `Measurement` is displayed.
- Select another program branch to display the parameters.

Notice!

The parameters cannot be changed during the measurement. When attempting to change the parameters, the message `Read-only mode` will be displayed.

The measurement has to be stopped in order to change the parameters.

Information regarding the data logger

Information regarding the data logger can be displayed during the measurement.

- Press key  until the following is displayed:

Fig. 9.7: Information regarding the data logger



If the ringbuffer is not activated, the time the data logger is full in case all settings were kept will be indicated in line 4. If the ringbuffer is activated, line 4 will indicate how long measurement data can be stored without losing older measurement data.

The information regarding the data logger can also be displayed via the function `Show parameters`.

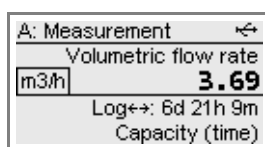
```
Special functions\Data logger
```

- Select the list item `Data logger info` in the menu item `Data logger`.
- Press ENTER.

The following information regarding the data logger is displayed.

Display of the current temperature offset

If the calculation of the fluid temperature from the sound speed is activated, the temperature offset can be displayed during the measurement.

Options\Special settings\Fluid: c -> T

- Select the menu item `Special settings` in the program branch `Options`.
- Press ENTER until the menu item `Fluid: c -> T` is displayed.

The following display appears:

Fig. 9.8: Display of the temperature offset

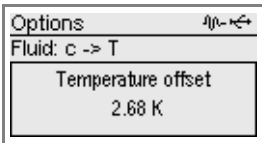

9.6 Repeated display of measured values

- Select the program branch `Measurement` to return to the measured value display.
- Press ENTER.

The following display appears:

Fig. 9.9: Scroll list in the program branch `Measurement`

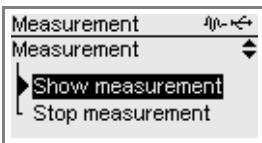

Measurement\Show measurement

- Select `Show measurement` in the scroll list.
- Press ENTER.

The measured values are displayed.

9.7 Execution of special functions

Some of the keys have special functions. They can be used to enter data, to navigate through scroll lists and to execute special functions.

Tab. 9.8: Special functions

key	function
[1]	toggling between the AutoMux and HumanMux mode
[8]	totalizer display
[5]	triggering snaps
[7]	toggling between the displays of the activated channels
[0]	toggling between the TransitTime and the FastFood mode
[-]	toggling between the TransitTime and the NoiseTrek mode
[↩]	display of scroll list in the program branch <code>Measurement</code>
ENTER	display of diagnostic window

9.8 Stop of the measurement

- Press key  during the measurement.

The following display appears:

Fig. 9.10: Scroll list in the program branch `Measurement`

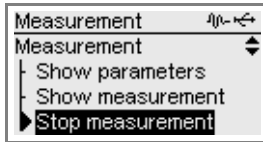

```
Measurement\Stop measurement
```

- Select `Stop measurement`.
- Press ENTER.

The measurement is stopped. The program branch `Parameters` is displayed.

After disconnecting and reconnecting the power supply, the program branch `Parameters` appears.

10 Troubleshooting

Warning!



Service works by unauthorized and unqualified personnel

This may result in personal or material damage or dangerous situations.

→ Any work on the transmitter has to be carried out by authorized and qualified personnel.

Danger!



Working in mines or cramped confines

Risk of intoxication and/or asphyxiation because of emerging gases, risk of injuries because of cramped conditions.

→ Wear the required personal protective equipment.

→ Observe the applicable rules.

Caution!



Safety and accident prevention regulations for electrical systems and equipment

Failure to observe these regulations may lead to severe injuries.

→ Observe the safety and accident prevention regulations for electrical systems and equipment.

Warning!



Touching live parts

Electric shock or arc faults can lead to severe injuries. The measuring equipment can be damaged.

→ Prior to any work on the transmitter (e.g., installation, dismounting, connection, start-up), the transmitter has to be disconnected from the power supply. It is not sufficient to remove the internal fuse of the instrument.

Caution!



Touching hot or cold surfaces

This may result in injuries (e.g., thermal damages).

→ Observe the ambient conditions at the measuring point during installation.

→ Wear the required personal protective equipment.

→ Observe the applicable rules.

If any problem appears which cannot be solved with the help of this operating instruction, contact our sales office and give a precise description of the problem. Specify the type, the serial number and the firmware version of the transmitter.

The display does not work at all or fails regularly.

Check the contrast setting of the transmitter or enter the HotCode **555000** to set the display to medium contrast.

Make sure that the correct voltage is available at the terminals. The destined transmitter voltage is indicated on the nameplate below the outer right terminal strip.

If the power supply is OK, the transducers or an internal component of the transmitter are defective. The transducers and the transmitter have to be sent to FLEXIM for repair.

If the transmitter is only connected via the USB interface, the backlight will be switched off.

An error is displayed in the status indication (symbol )

Press  to return to the main menu. Select the menu item `Special functions\System settings\Event log`. Press ENTER. The error message list will be displayed.

Date and time are wrong, the measured values are deleted when the transmitter is switched off.

The data backup battery has to be replaced if the date and the time are reset or wrong or the measured values are deleted after the transmitter has been switched off and on again. Send the transmitter to FLEXIM.

An output does not work.

Make sure that the outputs are configured correctly. Check the function of the output. If the output is defective, contact FLEXIM.

10.1 Problems with the measurement

A measurement is not possible because no signal is received. A question mark is displayed after the physical quantity. The LED lights red after starting the measurement.

- Check whether the entered parameters are correct, especially the outer pipe diameter, the pipe wall thickness and the sound speed of the fluid. Typical errors: The circumference or the radius was entered instead of the diameter. The inner pipe diameter was entered instead of the outer pipe diameter.
- Check the number of sound paths.
- Make sure that the recommended transducer distance was adjusted when mounting the transducers.
- Make sure that an appropriate measuring point is selected and the number of sound paths was entered correctly.
- Try to establish a better acoustic contact between the pipe and the transducers.
- Enter a lower value for the number of sound paths. The signal attenuation might be too high due to a high fluid viscosity or deposits on the inner pipe wall.

The measuring signal is received but no measured values can be obtained

- If the defined upper limit of the flow velocity is exceeded or the lower limit is below, `UNDEF` and after the physical quantity an exclamation point will be displayed. The measured values are marked as invalid. The limit has to be adapted to the measuring conditions.
- If no exclamation point is displayed, a measurement at the selected measuring point is impossible.

The signal is lost during the measurement.

- If there is no measuring signal after the pipe had been run empty and refilled, contact FLEXIM.
- Wait a moment until the acoustic contact is reestablished. The measurement can be interrupted due to a temporarily higher proportion of gas bubbles and solids in the fluid.

The measured values substantially differ from the expected values.

- Wrong measured values are often caused by wrong parameters. Make sure that the parameters entered for the measuring point are correct.

10.2 Measuring point selection

- Make sure that the recommended min. distance to any disturbance is observed.
- Avoid measuring points with deposit formation in the pipe.
- Avoid measuring points in the vicinity of deformations and defects on the pipe as well as welds.
- Make sure the pipe surface at the selected measuring point is even.
- Measure the temperature at the measuring point and make sure that the transducers are suitable for this temperature.
- Make sure that the outer pipe diameter is within the measuring range of the transducers.
- When measuring on a horizontal pipe, the transducers have to be mounted laterally on the pipe.
- The measuring point on a vertically mounted pipe has always to be filled. The fluid should flow upward.
- No gas bubbles should form (even bubble-free fluids can form gas bubbles when the fluid expands, e.g., upstream of pumps and downstream of great cross-section enlargements).

10.3 Maximum acoustic contact

see section 6.2

10.4 Application-specific problems

A fluid with a wrong sound speed was selected.

If the selected sound speed in the fluid does not match the actual one, the transducer distance can probably not be determined correctly.

The fluid sound speed is used to calculate the transducer distance and is therefore very important for the transducer positioning. The sound speeds stored in the transmitter only serve as an orientation.

The entered pipe roughness is not appropriate.

Check the entered value. The pipe state should be considered.

Measurements on pipes made of porous materials (e.g., concrete or cast iron) are only conditionally possible.

Contact FLEXIM.

The pipe lining may cause problems during the measurement if it is not firmly attached to the inner pipe wall or consists of acoustically absorbing material.

Try to measure on a section of the pipe free from lining.

Highly viscous fluids strongly attenuate the ultrasonic signal.

The measurement of fluids with a viscosity of $> 1000 \text{ mm}^2/\text{s}$ is only conditionally possible.

Gas bubbles or solids present in high concentration in the fluid scatter and absorb the ultrasonic signal and thus attenuate the measuring signal.

A measurement is impossible if the value is $\geq 10 \%$. If the proportion is high, but $< 10 \%$, a measurement is only conditionally possible.

10.5 Significant deviations of the measured values

A fluid with a wrong sound speed was selected.

If a fluid was selected whose sound speed does not match the actual one, a pipe wall signal can be mistaken for the measuring signal.

The flow calculated by the transmitter on the basis of the wrong signal is very small or fluctuates around zero.

There is gas in the pipe.

If there is gas in the pipe, the measured flow will be too high because both the liquid and the gas volume are measured.

The defined upper limit of the flow velocity is too low.

All measured flow velocities that are greater than the upper limit will be ignored and marked as invalid. All quantities deviated from the flow velocity will also be indicated as invalid. If several correct measured values are ignored, the totalizer values will be too low.

The entered cut-off flow is too high.

All flow velocities below the cut-off flow are set to zero. All derived quantities are also set to zero. The cut-off flow has to be set to a low value to be able to measure at low flow velocities (default: 2.5 cm/s).

The entered pipe roughness is not appropriate.

The flow velocity of the fluid is outside the measuring range of the transmitter.

The measuring point is not appropriate.

Check whether a different measuring point provides better results. Because pipes are never rotationally symmetric, the flow profile is affected.

10.6 Problems with the totalizers

The values of the totalizers are too small

One of the totalizers has reached the upper limit and has to be reset to zero manually.

The sum of the totalizers is not correct

The output sum of both totalizers (throughput ΣQ) transmitted via an output is not valid after one of the totalizers has overflowed for the first time.

A question mark is displayed after the value of the totalizer

The measurement was temporarily impossible, therefore the totalizer value can be wrong.

11 Maintenance and cleaning

Warning!

**Service works by unauthorized and unqualified personnel**

This may result in personal or material damage or dangerous situations.

→ Any work on the transmitter has to be carried out by authorized and qualified personnel.

Danger!

**Working in mines or cramped confines**

Risk of intoxication and/or asphyxiation because of emerging gases, risk of injuries because of cramped conditions.

→ Wear the required personal protective equipment.

→ Observe the applicable rules.

Warning!

**Touching live parts**

Electric shock or arc faults can lead to severe injuries. The measuring equipment can be damaged.

→ Prior to any work on the transmitter (e.g., installation, dismounting, connection, start-up), the transmitter has to be disconnected from the power supply. It is not sufficient to remove the internal fuse of the instrument.

Caution!

**Safety and accident prevention regulations for electrical systems and equipment**

Failure to observe these regulations may lead to severe injuries.

→ Observe the safety and accident prevention regulations for electrical systems and equipment.

Caution!

**Touching hot or cold surfaces**

This may result in injuries (e.g., thermal damages).

→ Observe the ambient conditions at the measuring point during installation.

→ Wear the required personal protective equipment.

→ Observe the applicable rules.

11.1 Maintenance

The transmitter and the transducers are practically maintenance-free. In order to ensure security, the following maintenance intervals are recommended:

Tab. 11.1: Recommended maintenance intervals

item	maintenance step	interval	measure
stainless steel housing • transmitter • junction box • transducer mounting fixture	visual inspection for corrosion and damages	annually or more frequently, depending on the ambient conditions	cleaning
	visual inspection for contamination	annually or more frequently, depending on the ambient conditions	
aluminum housing • transmitter	visual inspection for contamination	annually or more frequently, depending on the ambient conditions	
transducers	check of the transducer coupling on the pipe	annually	replacement of coupling foil, if necessary
transmitter	check for firmware updates	annually	update, if necessary
transmitter	functional test	annually	reading of measured and diagnostic values
transmitter and transducers	calibration	-	see section 11.3

11.2 Cleaning

Stainless steel housing

- Clean the housing with a soft cloth and care and cleaning spray for stainless steel.

Aluminum housing

- Clean the housing with a soft cloth. Do not use detergents.

Transducers

- Remove traces of coupling compound from the transducers with a soft paper towel.

11.3 Calibration

If installed as recommended in an appropriate location, used cautiously and serviced conscientiously, no troubles should appear.

The transmitter has been calibrated at factory and, usually, a recalibration is not necessary.

A recalibration is recommended if:

- the contact surfaces of the transducers show visible wear or
- the transducers were used for a prolonged period at high temperatures (several months > 130 °C for normal transducers or > 200 °C for high temperature transducers)

In order to realize a recalibration under reference conditions, either the transmitter, the transducers or both have to be sent to FLEXIM.

11.4 Firmware update

A firmware update is carried out with FluxDiagReader or FluxDiag (option).

- For the connection of the transmitter to a PC, see section 7.5.
- For the operation of the programs see FluxDiagReader support or FluxDiag support.

12 Dismounting and disposal

Warning!



Installation, connection and start-up by unauthorized and unqualified personnel

This may result in personal or material damage or dangerous situations.

→ Any work on the transmitter has to be carried out by authorized and qualified personnel.

Danger!



Working in mines or cramped confines

Risk of intoxication and/or asphyxiation because of emerging gases, risk of injuries because of cramped conditions.

→ Wear the required personal protective equipment.

→ Observe the applicable rules.

Warning!



Touching live parts

Electric shock or arc faults can lead to severe injuries. The measuring equipment can be damaged.

→ Prior to any work on the transmitter (e.g., installation, dismounting, connection, start-up), the transmitter has to be disconnected from the power supply. It is not sufficient to remove the internal fuse of the instrument.

Caution!



Safety and accident prevention regulations for electrical systems and equipment

Failure to observe these regulations may lead to severe injuries.

→ Observe the safety and accident prevention regulations for electrical systems and equipment.

12.1 Dismounting

The dismounting is carried out in reverse order to the installation.

12.2 Disposal

The measuring equipment has to be disposed of in accordance with the applicable regulations.

Important!

Avoiding environmental damage by correct disposal of components

Depending on the material, the corresponding parts have to be disposed of in residual or special waste or recycled. FLEXIM accepts the return of the components. For further information, contact FLEXIM.

13 User modes

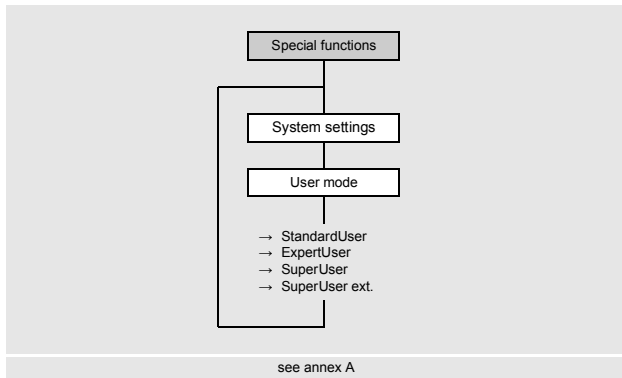

The user modes enable an advanced diagnostic of signal and the measured values as well as the definition of additional parameters adapted to the application.

The following user modes can be selected:

- StandardUser
- ExpertUser
- SuperUser
- SuperUser ext.

Depending on the selected user mode, further options are displayed in the program branch Options\Channel\Special settings.

Tab. 13.1: Menu items of the user modes

Options\Special settings	StandardUser	ExpertUser	SuperUser	SuperUser ext.	default value
Cut-off flow	x	x	x	x	On
Flow velocity limit		x	x	x	Off
PIG detection			x	x	
Turbulence mode	x	x	x	x	Off
Max. amplification		x	x	x	Off
Pipe signal detection		x	x	x	On
LWT pipe wall calibr.			x	x	Off
Linear calibration			x	x	Off
Profile correction		x	x	x	On
Weighting factor			x	x	Off
Fluid: c -> T	x	x	x	x	Off
Multi-point calibration (if enabled in Special functions\Measurement\Measurement settings)	x	x	x	x	
Start in meas. mode	x	x	x	x	
Transducer temp. and Transd. temp. violat. (as source item Diagnostic values)			x	x	
Extended diagnost. (in the program branch Options, calculation channel)		x	x	x	

User mode selection

```
Special functions\System settings\User mode
```

- Select the menu item `User mode`.
- Press ENTER.
- Select `StandardUser`.
- Press ENTER.

Special settings

```
Options\Special settings
```

- Select the measuring channel in the program branch `Options`.
- Press ENTER.
- Select the list item `Special settings`.
- Press ENTER.

The menu items of the user mode are consecutively displayed.

13.1 StandardUser mode

In the `StandardUser` mode, all measurements can be carried out for the corresponding application. At the first start-up the transmitter operates in the `StandardUser` mode.

13.1.1 Cut-off flow

The cut-off flow is a lower limit for the flow velocity. All measured flow velocities that are below the limit are set to zero. The cut-off flow can depend on the flow direction.

```
Options\Special settings\Cut-off flow
```

- Select the menu item `Special settings` in the program branch `Options`.
- Press ENTER until the menu item `Cut-off flow` is displayed.
- Select `Off` if no value is to be entered for the cut-off flow.
- Select `Default` if no customized inputs are to be made (default: ± 25 mm/s).
- Select `Customized` to define the cut-off flow value.
- Press ENTER.

```
Options\Special settings\+Cut-off flow
```

All positive values of the flow velocity below this limit are set to zero.

- Enter the cut-off flow.
- Press ENTER.

```
Options\Special settings\ -Cut-off flow
```

All negative values of the flow velocity above this limit will be set to zero.

- Enter the cut-off flow.
- Press ENTER.

13.1.2 NoiseTrek mode

If the proportion of gas or solid particles is high, the transmitter can toggle to the NoiseTrek mode.

Notice!

Due to its higher measuring accuracy, the TransitTime mode should be used preferentially over the NoiseTrek mode. In the NoiseTrek mode it is not possible to determine the sound speed in the fluid. The following diagnostic values are not available in the NoiseTrek mode: signal quality, amplitude fluctuation, transit time fluctuation, pig detection.

```
Options\Special settings\Enable NoiseTrek
```

- Select the menu item `Special settings` in the program branch `Options`.
- Press ENTER until the menu item `Enable NoiseTrek` is displayed.
- Select `Default` if no customized inputs are to be made.
- Select `On` to enable the NoiseTrek mode, to disable it. Select `Off` to disable it.
- Press ENTER.

In order to manually toggle between the TransitTime and the NoiseTrek mode during the measurement, press key when the measured value is displayed.

13.1.3 HybridTrek mode

The HybridTrek mode combines the TransitTime and the NoiseTrek mode. During a measurement in the HybridTrek mode, the transmitter automatically toggles between the TransitTime and the NoiseTrek mode depending on the gaseous or solid content in the fluid in order to receive valid measuring values.

If the NoiseTrek mode is enabled, the menu item `HybridTrek` will be displayed.

```
Options\Special settings\HybridTrek
```

- Select `On` to activate the automatic toggling between the TransitTime and the NoiseTrek mode. If `On` is selected, the NoiseTrek mode can also be activated and deactivated manually during the measurement.
- Select `Off` to deactivate the automatic toggling between the TransitTime and the NoiseTrek mode. If `Off` is selected, the NoiseTrek mode can only be manually activated and deactivated during the measurement.
- Press ENTER.

```
Options\Special settings\HybridTrek\TT -> NT
```

If the automatic toggling between the TransitTime and NoiseTrek mode is activated, further parameters have to be configured.

- Enter the time after which the transmitter has to toggle to the NoiseTrek mode if there are no valid measured values in the TransitTime mode.
- Press ENTER.

```
Options\Special settings\HybridTrek\NT -> TT
```

- Enter the time after which the transmitter has to toggle from the NoiseTrek to the TransitTime mode if there are no valid measured values.
- Press ENTER.

```
Options\Special settings\HybridTrek\NT -> TT possible
```

If there are valid measured values in the NoiseTrek mode, the transmitter can periodically toggle to the TransitTime mode in order to check whether a measurement in the TransitTime mode is possible again. The time interval and the duration of the checking are set as follows:

- Enter the time after which the transmitter has to toggle to the TransitTime mode. If zero is entered, the transmitter does not toggle to the TransitTime mode.
- Press ENTER.

```
Options\Special settings\HybridTrek\Keep TT
```

- Enter the time after which the transmitter has to toggle from the TransitTime mode back to the NoiseTrek mode if there are no valid measured values.
- Press ENTER.

Example

```
TT -> NT: 40 s
NT -> TT: 60 s
NT -> TT possible: 300 s
Keep TT: 5 s
```

If no measurement is possible in the TransitTime mode within 40 s, the transmitter toggles to the NoiseTrek mode. If no measurement is possible in the NoiseTrek mode within 60 s, the transmitter toggles back to the TransitTime mode.

If valid measured values are obtained during the measurement in the NoiseTrek mode, the transmitter toggles to the TransitTime mode every 300 s. If no measurement is possible in the TransitTime mode for the duration of 5 s, the transmitter toggles back to the NoiseTrek mode. If a valid measured value is obtained in the TransitTime mode within 5 s, the transmitter continues the measurement in the TransitTime mode.

13.1.4 Turbulence mode

The activation of the turbulence mode can enhance the signal quality if the flow is highly turbulent (e.g., in the vicinity of an elbow or valve). An SNR value of min. 6 dB is required during the measurement.

```
Options\Special settings\Turbulence mode
```

- Select the menu item `Special settings` in the program branch `Options`.
- Press ENTER until the menu item `Turbulence mode` is displayed.
- Select `On` to activate the turbulence mode. Select `Off` to deactivate it.
- Select `Default` if no customized inputs are to be made.
- Press ENTER.

13.1.5 Multi-point calibration

It is possible to enter a series of measured values in order to define a calibration curve for the flow velocity.

Record of series of measured values:

- Start a measurement with the transmitter and a reference flowmeter.
- Gradually increase the value of the flow velocity. The measuring range of values has to be identical with the eventual operating range.
- Note or store the measured values.

Input of measured values:

- Select the menu item `Special settings` in the program branch `Options`.
- Press ENTER until the menu item `Multi-point calibration` is displayed.

```
Options\Special settings\Multi-point calibration
```

- Select `Yes` to define the calibration curve. Select `No` to measure without calibration.
- Press ENTER.

```
Options\Special settings\Multi-point calibration\Calibration points
```

- Enter the number of pairs of measured values.
- Press ENTER.

```
Options\Special settings\Multi-point calibration\Point x=act. value
```

- Enter the measured values of the transmitter.
- Press ENTER.

```
Options\Special settings\Multi-point calibration\Point x=set value
```

- Enter the measured values of the reference flowmeter.
- Press ENTER.
- Repeat the input for all pairs of measured values.
- Press ENTER after each input.

```
Options\Special settings\Multi-point calibration\Bidirectional use
```

- Select `Yes` to also apply the calibration curve for negative flow velocities. Select `No` if it is not to be used for negative flow velocities.

13.1.6 Start in measuring mode

For some application it is necessary to start the measurement in a particular measuring mode.

```
Options\Special settings\Start in meas. mode
```

- Select the menu item `Special settings` in the program branch `Options`.
 - Press `ENTER` until the menu item `Start in meas. mode` is displayed.
- The menu item `Start in meas. mode` will only be displayed if `FastFood` or `NoiseTrek` mode is enabled.
- Select `TransitTime`, `FastFood`, `NoiseTrek` to start the measurement in the corresponding mode.
 - Press `ENTER`.

```
Options\Special settings\Start in meas. mode\Only ... mode
```

- Select `Yes` to keep always the same the measuring mode. Select `No` to select another measuring mode by pressing key during the measurement.

The measuring modes `FastFood` and `NoiseTrek` can only be selected if they are available and activated in the transmitter.

13.1.7 Calculation of the fluid temperature from the sound speed of the fluid

```
Options\Special settings\Fluid: c -> T
```

- Select the menu item `Special settings` in the program branch `Options`.
- Press `ENTER` until the menu item `Fluid: c -> T` is displayed.
- Select `On` if the calculated fluid temperature from the sound speed has to be calculated. Select `Off` if not.
- Press `ENTER`.

13.2 ExpertUser mode

Some menu items that are not visible in the StandardUser mode are displayed.

Notice!
The ExpertUser mode is intended for experienced users with advanced application knowledge. Changed parameters can affect the StandardUser mode and lead to wrong measured values or to a failure of the measurement when setting up a new measuring point.

Notice!
Some of the defined parameters remain active after the activation of the StandardUser mode. These parameters are displayed but cannot be changed.

13.2.1 Limit of the flow velocity

Single outliers caused by heavily disturbed surroundings can appear among the measured values of the flow velocity. If these outliers are not ignored, they will affect all derived physical quantities, which will be unsuitable for the integration (e.g., pulse outputs).

In the ExpertUser mode it is possible to enter a limit for the flow velocity.

It is possible to ignore all measured flow velocities higher or lower than the preset limit. In this case an error will be output.

Options\Special settings\Flow velocity limit

- Select the menu item `Options` in the program branch `Special settings`.
- Press ENTER until the menu item `Flow velocity limit` is displayed.
- Select `Off` if no limit for the flow velocity is to be used.
- Select `Default` if no customized inputs are to be made.
- Select `Customized` to define a limit for the flow velocity.
- Press ENTER.

Options\Special settings\+Flow velocity limit

- Enter a limit of the flow velocity for the measurement in flow direction.
- Press ENTER.

If the flow velocity is higher than this limit, it will be marked as invalid. The physical quantity cannot be determined. `UNDEF` and an exclamation point will be displayed after the physical quantity and unit of measurement of the flow velocity.

Options\Special settings\ -Flow velocity limit

- Enter a limit of the flow velocity for the measurement against the flow direction.
- Press ENTER.

If the flow velocity is lower than this limit, it will be marked as invalid. The physical quantity cannot be determined. `UNDEF` and an exclamation point will be displayed after the physical quantity and unit of measurement of the flow velocity.

Fig. 13.1: Flow velocity outside the valid range

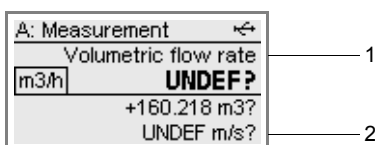

- 1 – physical quantity
- 2 – flow velocity

Notice!

If the limit of the flow velocity +Flow velocity limit is too low or -Flow velocity limit too high, a measurement might be impossible because most of the measured values will be marked as invalid.

13.2.2 Max. signal amplification

In order to prevent disturbing and/or pipe wall signals (e.g., if the pipe has run empty) from being interpreted as useful signals, it is possible to define a max. signal amplification.

If the signal amplification is greater than the max. signal amplification:

- the physical quantity cannot be determined and the measured value is marked as invalid
- a hash symbol will be displayed after the unit of measurement (in case of a normal error, an interrogation point is displayed)

Options\Special settings\Max. amplification

- Select the menu item `Options` in the program branch `Special settings`.
- Press `ENTER` until the menu item `Max. amplification` is displayed.
- Select `Off` if no limit of the signal amplification is to be used.
- Select `Default` if no customized inputs are to be made.
- Select `Customized` to define a limit for the max. amplification.
- Press `ENTER`.
- Enter a value for the max. signal amplification.
- Press `ENTER`.

13.2.3 Pipe signal detection

When evaluating the plausibility of the signal, it is checked whether the sound speed is within a defined range. The absolute threshold of the flow velocity of the fluid used is calculated from the greatest of the following values:

- absolute threshold, default value: 1848 m/s
- value of the sound speed curve of the fluid at the operating point plus relative threshold, default relative threshold: 200 m/s

Options\Special settings\Pipe signal detection

- Select the menu item `Options` in the program branch `Special settings`.
- Press `ENTER` until the menu item `Pipe signal detection` is displayed.
- Select `Off` to measure without pipe signal detection.
- Select `Default` if no customized inputs are to be made and the default values are to be used.
- Select `Customized` to define the values of the pipe signal detection.
- Press `ENTER`.

Options\Special settings\Absolute threshold

- Enter the value of the absolute threshold for the particular measuring channel.
- Press `ENTER`.

Options\Special settings\Relative threshold

- Enter the value for the relative threshold for the particular measuring channel.
- Press `ENTER`.

Example

absolute threshold: 2007 m/s

relative threshold: 600 m/s

value of the sound speed curve at the measuring point: 1546 m/s

As $1546 \text{ m/s} + 600 \text{ m/s} = 2146 \text{ m/s}$ is greater than the absolute value 2007 m/s, this value will be used as the absolute limit of the sound speed when the plausibility of the signal is evaluated.

13.2.4 Profile correction

It is possible to select the following versions for the calculation of the fluid mechanics calibration factor k_{Re} :

- $k_{Re} 1.0$: profile correction (previous version)
- $k_{Re} 2.0$: improved profile correction (current version, default)
- $k_{Re} 2.0 \text{ disturb. corr.}$: improved profile correction at non ideal inflow conditions

The following steps are necessary to set the profile correction:

- The profile correction versions for all measuring channels can be selected in the program branch `Special functions`.
- Input of the disturbance distance in the program branch `Parameters` if $k_{Re} 2.0 \text{ disturb. corr.}$ has been selected.

If $k_{Re} 2.0 \text{ disturb. corr.}$ has been selected, the transducers have to be mounted in reflection arrangement, x arrangement or displaced x arrangement to compensate cross low effects. When mounting in x arrangement it is essential to set the same parameters on all measuring channels and to activate one calculation channel with average generation for both measuring channels.

Selection of the versions

```
Special functions\Measurement\Measurement settings\Profile correction
```

- Select the menu item `Special functions` in the program branch `Measurement settings`.
- Press ENTER until the menu item `Profile correction` is displayed.
- Select a list item (default: $k_{Re} 2.0$).
- Press ENTER.

Input of the disturbance distance

```
Parameters\Disturbance distance
```

- Enter the disturbance distance.
- Press ENTER.

This display will only be indicated if the list item $k_{Re} 2.0 \text{ disturb. corr.}$ is selected in the menu item `Special functions\Measurement\Measurement settings`.

Measuring point specific profile correction

In special cases a measuring point specific profile correction can be used.

```
Options\Special settings\Profile correction
```

- Select the program branch `Options`.
- Press ENTER.
- Select a channel for which the profile correction is to be set.
- Select the menu item `Special settings`.
- Press ENTER until the menu item `Profile correction` is displayed.
- Select `Off` to deactivate the profile correction for the channel.
- Select `Default` to use the global setting for the profile correction from the program branch `Special functions`.
- Select `Customized` to use the measuring point specific profile correction.
- Press ENTER.

In case the list item `Customized` has been selected, the parameters of the measuring point specific profile correction will now be displayed. The parameters of the profile correction are transmitted to the transmitter via the service interface but can also be entered here.

13.2.5 Extended diagnostic

There are further diagnostic values available for the calculation channels. These can either be transmitted via the outputs of the transmitter or defined as source of the event trigger.

13.3 SuperUser mode and SuperUser ext. mode

Some menu items that are not visible in the `StandardUser` or `ExpertUser` mode are now displayed.

In the `SuperUser ext. mode` it is not possible to carry out any plausibility test of the entered parameters.

Notice!

The `SuperUser` and `SuperUser ext. mode` is intended for experienced users with advanced application knowledge. Changed parameters can affect the `StandardUser` mode and lead to wrong measured values or to a failure of the measurement when setting up a new measuring point.

Notice!

Some of the defined parameters remain active after the activation of the `StandardUser` mode. These parameters are displayed but cannot be changed.

13.3.1 Pig detection

This function detects pigs inside the pipe.

The pig detection can be activated/deactivated via the HotCode **007028**.

Deviating from the global device settings, the pig detection for particular channels can be activated or deactivated.

```
Options\Special settings\PIG detection
```

- Select the menu item `Special settings` in the program branch `Options`.
- Press ENTER until the menu item `PIG detection` is displayed.
- Select `Global settings` if the measurement is to be carried out using the global settings of the transmitter.
- If the pig detection has been deactivated in the global device settings and the measurement is to be carried out with pig detection on this channel, select `On` for this channel.
- Press ENTER.
- If the pig detection has been activated in the global device settings and the measurement is to be carried out without pig detection on a channel, select `Off` for this channel.
- Press ENTER.

13.3.2 Pipe wall calibration for Lamb wave transducers

The parameter record of a measuring channel for Lamb wave transducers has a calibration factor for the uncorrected flow velocity. This calibration factor depends on the pipe material.

The pipe wall calibration for Lamb wave transducers becomes effective if the following criteria are met when starting a measurement:

- Lamb wave transducers are used
- pipe wall calibration is activated
- a factor for the pipe material is defined and selected from the program branch `Parameters`

The factor can be activated in the transmitter.

```
Options\Special settings\LWT pipe wall calibr.
```

- Select the menu item `Special settings` in the program branch `Options`.
- Press ENTER until the menu item `LWT pipe wall calibr.` is displayed.
- Select `Off` to measure without pipe wall calibration.
- Select `Default` if no customized inputs are to be made.
- Select `On` to define the values for the pipe wall calibration.
- Press ENTER.

13.3.3 Linear calibration

It is possible to define a correction of the flow velocity:

$$v_{\text{cor}} = m \cdot v + n$$

where

- v – measured flow velocity
- m – factor, range: -2...+2
- n – offset, range: -12...+12 cm/s
- v_{cor} – corrected flow velocity

All quantities derived from the flow velocity will be calculated with the corrected flow velocity.

Notice!

It will not be displayed that the correction of the flow velocity is active during the measurement.

```
Options\Special settings\Linear calibration
```

- Select the menu item `Special settings` in the program branch `Options`.
- Press ENTER until the menu item `Linear calibration` is displayed.
- Select `Off` to measure without linear calibration.
- Select `Default` if no customized inputs are to be made.
- Select `On` to define the values for the calibration.
- Press ENTER.

```
Options\...\Factor
```

- Enter the factor for the linear calibration.
- Press ENTER.

```
Options\...\Offset
```

- Enter the offset for the linear calibration.
- Press ENTER.

Example

factor: 1.1

offset: -10 cm/s = -0.1 m/s

If a flow velocity $v = 5$ m/s is measured, before the calculation of the derived quantities it will be corrected as follows:

$$v_{\text{cor}} = 1.1 \cdot 5 \text{ m/s} - 0.1 \text{ m/s} = 5.4 \text{ m/s}$$

Example

factor: -1

offset: 0

Only the sign of the measured values changes.

Notice!

The correction data will not be stored before a measurement is started.

If the transmitter is switched off without starting a measurement, the entered correction data will be lost.

13.3.4 Weighting factor

The weighting factor is used for transducers installed on the same pipe in order to compensate differences between the measured values of the flow velocity of different channels.

The differences can be caused by profile deformations or transverse flows. These influences can be reduced by averaging the measured values of several channels. If a channel has a temporary malfunction, the average will change abruptly. In order to avoid differences, all channels have to be adjusted with the weighting factor.

The weighting factor for the channel x results from the flow velocity v_x and the average flow velocity of all channels

v_{average} :

$$w_x = \frac{v_{\text{average}}}{v_x}$$

The weighting factor can be activated in the transmitter.

Options\Special settings\Weighting factor

- Select the menu item `Special settings` in the program branch `Options`.
- Press ENTER until the menu item `Weighting factor` is displayed.
- Select `Off` to measure without the weighting factor.
- Select `Default` if no customized inputs are to be made.
- Select `On` to define the weighting factor.
- Press ENTER.

13.3.5 Calculation of the fluid temperature from the sound speed of the fluid

Options\Special settings\Fluid: c -> T

- Select the menu item `Special settings` in the program branch `Options`.
- Press ENTER until the menu item `Fluid: c -> T` is displayed.
- Select `On` if the calculated fluid temperature from the sound speed has to be calculated. Select `Off` if not.
- Press ENTER.

If the transmitter is operating in the `SuperUser 0 SuperUser ext.` and `On` is selected, the options of temperature determination will be displayed.

Options\Special settings\Fluid: c -> T\Temperature meas.

- Select `With calibration` to realize a calibration for the temperature determination.

From the difference between the entered fluid temperature and the sound speed of the calculated fluid temperature an offset is determined, when starting the measurement. The fluid temperature has to be entered.

- Press ENTER.
- Select `Without calibration` if no measured value for the temperature is available.
- Press ENTER.

Notice!

If the determination of the fluid temperature from the sound speed without calibration may lead to notable temperature deviations.

- Select `Customized` to enter an offset.
- Press ENTER.
- Enter the offset.
- Press ENTER.

13.3.6 Transducer temperature and transducer temperature violation as diagnostic value

When configuring outputs, the list items `Transducer temp.` and `Transd. temp. violat.` are available in the menu item `Diagnostic values`. The diagnostic values can either be transmitted via the output of the transmitter or defined as source of the event trigger. The diagnostic value `Transducer temp.` is available on physical channels only.

Options\Channel...\Outputs\...\Source item

- Select `Diagnostic values as source item`.
- Press ENTER.
- Select a list item for the quantity to be output.
- Press ENTER.

Tab. 13.2: Source item `Diagnostic values`

source item	list item	output
Diagnostic values	Transducer temp.	average temperature of both transducers
	Transd. temp. violat.	status information: yes/no

14 Outputs

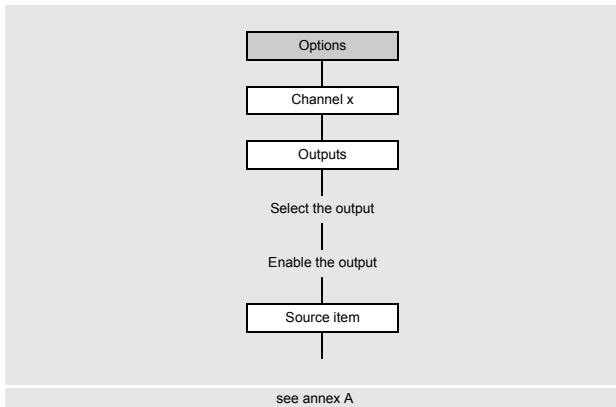

If the transmitter is equipped with outputs, they have to be configured. For the configuration of the analog output, see chapter 9, section 9.2.5.

The transmitter can also be equipped with binary outputs.

A binary output switches if one of the following switching condition is met:

- the measured value exceeds or falls below the limit
- the measured value lays within or outside a defined range
- a measurement is not possible
- an event occurs

14.1 Configuration of a binary output

- Select the program branch `Options`.
- Press ENTER.

Selection of the measuring channel

```
Options\Channel A
```

- Select the channel (here: `Channel A`)
- Press ENTER.

This display will not be indicated if the transmitter has only one measuring channel.

Assignment of an output

- Select `Outputs`.
- Press ENTER.

```
Options\Channel A\Outputs\Binary B1(--)
```

- Select the output to be assigned to the channel.
- Press ENTER.

If the channel has already been assigned to a channel, it is displayed as follows: `Binary B1 (A)`.

```
Options\Channel A\Outputs\Binary B1\B1 Enable
```

- Select `Yes` to change the settings for an already assigned output or to assign a new output.
- Select `No` to cancel the assignment and to return to the previous menu item.
- Press ENTER.

Assignment of a source item

Options\Channel A\Outputs\...\Source item

Depending on the selected source item, status or event values can be output.

Tab. 14.1: Output of status values or event values

	source item	status value	event value
physical quantities	Flow quantities	x	
	Fluid properties	x	
	Sound speed	x	
events	Event trigger		x

- Select the source item.
- Press ENTER.

14.1.1 Definition of the switching function for the status value/event value

Tab. 14.2: Selection of the switching condition

property	switching function	description
Status OK (measured value)	NC	<ul style="list-style-type: none"> • valid measured value: binary output is closed • invalid measured value: binary output is open
	NO	<ul style="list-style-type: none"> • valid measured value: binary output is open • invalid measured value: binary output is closed
Idle state (event value)	NO	<ul style="list-style-type: none"> • event occurs: binary output is closed • event has not occurred yet: binary output is open
	NC	<ul style="list-style-type: none"> • event occurs: binary output is open • event has not occurred yet: binary output is closed

If no measurement is carried out, all binary outputs are open (de-energized), independent of the set switching condition.

Terminal assignment

Options\Channel A\Outputs\...\Output info

The terminals for the connection of the output are displayed.
 By pressing key 2 or 8 further information is displayed.

- Press ENTER.

Output function test

The function of the output can now be tested.

- Connect a multimeter to the output.

```
Options\Channel A\Outputs\...\B1 Test signal
```

- Select **Yes** to test the output. Select **No** to display the next menu item.
- Press **ENTER**.

```
Options\Channel A\Outputs\...\B1 Enter test value
```

- Select **On** to test the energized state of the output.
- Press **ENTER**.

The value has to be low ohmic.

- Select **Off** to test the de-energized state of the output.
- Press **ENTER**.

The value has to be high ohmic.

- Select **Repeat** to repeat the test, **Finish** to display the next menu item.
- Press **ENTER**.

```
Options\Channel A\Outputs\...\B1 Test mea. range
```

- Select **Yes** to test the status of the output signal. Select **No** to display the next menu item.
- Press **ENTER**.

```
Options\Outputs\...\B1 Enter test value
```

- Select **Passive (idle state)** or **Active** in case a event has been selected as source item.
- Press **ENTER**.

Depending on the selected switching condition, the value has to be either high or low ohmic.

- Select **Repeat** to repeat the test, **Finish** to display the next menu item.
- Press **ENTER**.

14.2 Activation of a binary output as pulse output

A pulse output is an integrating output which emits a pulse when the volume or the mass of the fluid which has passed the measuring point, reaches a certain value (pulse value).

The integrated quantity is the selected physical quantity. The integration is restarted as soon as the pulse is emitted. Before the activation, the binary output has to be configured.

Notice!

The activation of a binary output as pulse output is only possible for binary outputs supporting a pulse output.

- Select the program branch `Options`.
- Press ENTER.

```
Options\Channel A\Outputs\Binary B1\Source item\Pulse
```

- Select `Pulse` as source item.
- Press ENTER.

```
Options\Channel A\Outputs\Binary B1\Source item\Pulse\Pulse +V
```

- Select a list item (here: `Pulse +V`).
- Press ENTER.

```
Options\Channel A\Outputs\Binary B1\Source item\Pulse\Pulse value
```

- Enter the pulse value.

The unit of measurement will be displayed according to the actual physical quantity.

When the counted physical quantity reaches the entered pulse value, a pulse will be transmitted.

```
Options\Channel A\Outputs\Binary B1\Source item\Pulse\Pulse width
```

- Enter the pulse width.

The range of possible pulse widths depends on the specification of the instrument (e.g., counter, PLC) that is to be connected to the output.

By pressing key `2` or `8` further information is displayed.

- Press ENTER.

15 Inputs (optional)

The inputs are configured in the program branch `Special functions` and assigned to the individual measuring channels in the program branch `Options`.

15.1 Configuration of an input

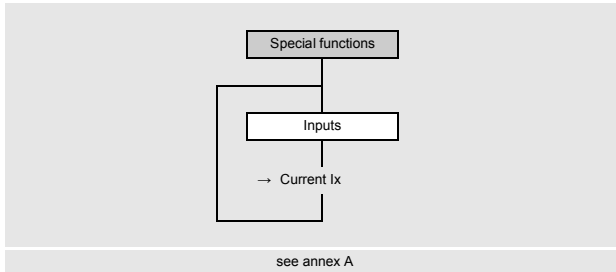

If the transmitter is equipped with inputs, they have to be configured.

- Select the program branch `Special functions`.
- Press ENTER.

```
Special functions\Inputs
```

- Select the input to be configured.
- Press ENTER.

The scroll list contains all available inputs.

- Select a list item:
 - `Current Ix (-)`

If the input has already been configured, it is displayed as follows: `Current I1 (+)`.

Enabling the input

If the input has to be used, it has to be enabled.

```
Special functions\Inputs\Current I1\Enable
```

- Select `Yes` to enable an input or change the settings for an already enabled input.
- Select `No` to uninstall an already configured input and to return to the previous menu item.
- Press ENTER.

15.1.1 Current inputs

When configuring the current inputs, the source item can now be selected and the input and measuring range is defined.

Selection of the source item

```
Special functions\Inputs\...\Source item
```

- Select the source item.

Input range

Now the input range is defined.

```
Special functions\Inputs\...\Input range
```

- Select a list item:
 - `0...20 mA`
 - `4...20 mA`
 - `Other range`

- Press ENTER.

If `Other range` is selected, enter the values `Input MIN` and `Input MAX`.

Measuring range

```
Special functions\Inputs\...\Start of meas. range
```

- Enter the lowest expected measured value. The unit of measurement of the source item will be displayed. `Start of meas. range` is the physical quantity assigned to the lower limit of the input range (`Input MIN`).
- Enter the highest expected measured value. The unit of measurement of the source item will be displayed. `End of meas. range` is the physical quantity assigned to the higher limit of the input range (`Input MAX`).

Input of an error value

```
Special functions\Inputs\...\Error value
```

It is possible to define an error value which is output if the source item is not available.

- Enter the error value.
- Press ENTER.

15.1.2 Definition of a switching condition

A switching condition can be defined.

```
Special functions\Inputs\...\Trigger value
```

- Select `Yes` if a switching condition is to be defined. Select `No` to display the next menu item.
- Press ENTER.

If a switching condition is defined, several transmitter functions can remotely be triggered.

```
Special functions\Inputs\...\Function
```

- Select a list item:
 - `MAX (x>limit)`: the switching condition is met if the measured value exceeds the limit.
 - `MIN (x<limit)`: the switching condition is met if the measured value falls below the limit
 - `ERR (x=fail)`: the switching condition is met if a measurement is not possible.
 - `Within range`: the switching condition is met if the measured value is within the defined range.
 - `Out of range`: the switching condition is met if the measured value is outside the defined range.
- Press ENTER.

```
Special functions\Inputs\...\Trigger value
```

- Enter the limit for the switching condition.
 - Press ENTER.
- This display will only be indicated if `MAX (x>limit)` or `MIN (x<limit)` is selected.

```
Special functions\Inputs\...\Hysteresis
```

It is possible to define a hysteresis to avoid a constant switching of the event trigger.

The event trigger will be activated if the measured value exceeds the upper limit and deactivated if it falls below the lower limit.

- Enter the value for the hysteresis.
- If zero is entered, no hysteresis is used.
- Press ENTER.

This display will only be indicated if `MAX (x>limit)` or `MIN (x<limit)` is selected.

```
Special functions\Inputs\...\Range center
```

- Enter the center of the switching range.
- Press ENTER.

This display will only be indicated if `Within range` or `Out of range` is selected.

```
Special functions\Inputs\...\Range width
```

- Enter the width of the switching range.
- Press ENTER.

This display will only be indicated if `Within range` or `Out of range` is selected.

```
Special functions\Inputs\...\Glitch interval
```

- Enter a time interval at the end of which the event trigger has to switch.
- Press ENTER.

15.1.3 Terminal assignment

```
Inputs\...\Input info
```

The terminals for the connection of the input are displayed.

By pressing key `2` or `8` further information is displayed.

- Press ENTER.

15.1.4 Function test of the input

The function of the installed input can now be tested.

Analog input

- Connect the signal source to the input.

```
Special functions\Inputs\...\I1 Test signal
```

- Select `Yes` to test the input signal. Select `No` to display the next menu item.
- Press ENTER.

```
Special functions\Inputs\...\I1 Test signal\Current
```

- If the transmitter displays a value (here: `Current`), the input functions.
- Press ENTER.
- Select `Repeat` to repeat the test, `Finish` to display the next menu item.
- Press ENTER.

```
Special functions\Inputs\...\I1 Test mea. range
```

- Select `Yes` to test the assignment of the measured value to the input signal. Select `No` to display the next menu item.
- Press ENTER.

```
Special functions\Inputs\...\I1 Test mea. range\Temperature
```

- If the transmitter displays a value (here: Temperature), the input functions.
- Press ENTER.
- Select *Repeat* to repeat the test, *Finish* to display the next menu item.
- Press ENTER.
- Press key  to return to the program branch *Options*.

15.2 Assignment of an input

- Select the program branch *Options*.
- Press ENTER.

```
Options\Channel ...
```

- Select the channel.
 - Press ENTER.
- This display will not be indicated if the transmitter has only one measuring channel.
- Select *Assign inputs*.
 - Press ENTER.

```
Options\Assign inputs
```

- Select the input to be assigned to the channel. Only the installed inputs are displayed in the scroll list.
- Select the list item *No linkage* if no input is to be assigned to the channel.
- Press ENTER.

16 Data logger

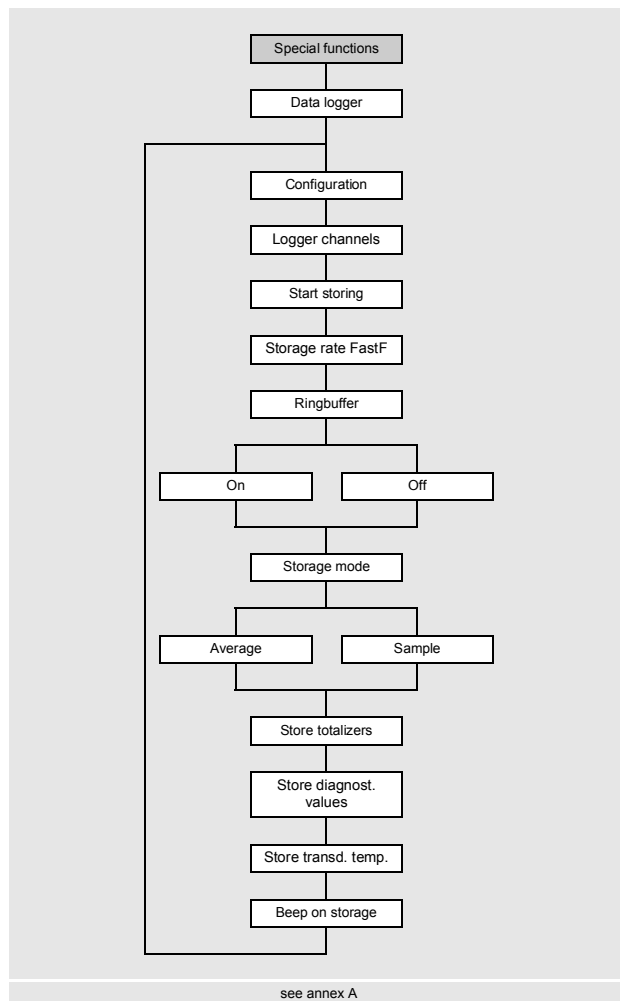

The transmitter has a data logger which stores the measured values during the measurement.

Notice!

In order to store measured data, the data logger has to be configured.

The following data can be stored:

- date
- time
- measuring point number
- pipe parameters
- fluid parameter
- transducer data
- physical quantity
- unit of measurement
- measured value

Measured values transmitted via the output are also stored in the data logger.

If the pulse values are transmitted via an output, the corresponding flow quantity and the totalizer value are stored in the data logger. In case of absolute pulse values, the values of both totalizers are stored.

16.1 Configuration of the data logger

Activation of the channels for storing

```
Special functions\Data logger\Configuration\Logger channels
```

- Select the menu item `Configuration`.
- Press ENTER.
- Activate the channels whose measured values have to be stored.
- Press key `<4>` or `<6>` to select a channel.
- Press key `<2>` to activate/deactivate a channel.
- Press ENTER.

Starting time

```
Special functions\Data logger\Configuration\Start storing
```

It is possible to set a starting time if it is necessary to synchronize the storing of measured values for several transmitters.

- Select the menu item `Configuration`.
- Press ENTER until the menu item `Start storing` is displayed.
- Select the moment at which the storing has to start.

display	description
Immediately	The storing starts immediately.
Full 5 minutes	The storing starts in the next full 5 minutes.
Full 10 minutes	The storing starts in the next full 10 minutes.
Full 15 minutes	The storing starts in the next full 15 minutes.
Full 30 minutes	The storing starts in the next full 30 minutes.
Full hour	The storing starts in the next full 60 minutes.
Event-based	The storing starts when a defined event occurs.

Example

actual time: 09:06 am
 setting: Full 10 minutes
 The storing starts at 09:10 am.

Notice!

Make sure that the time of all transmitters is synchronized.

Event-based starting time

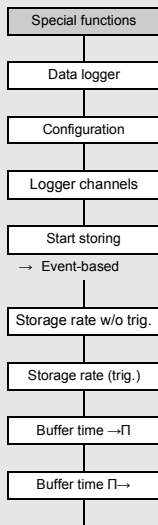

see annex A

```
Special functions\Data logger\
Configuration\Start storing\Event-based
```

If it is necessary to start the storing of measured values at a particular event, select *Event-based* as starting time. The event is signaled via an input or the event trigger. All configured inputs and event triggers are displayed in the scroll list.

- Select the input or the event trigger through which the event is to be signaled.
- Press ENTER.

```
Special functions\Data logger\
Configuration\Start storing\Event-based\
Storage rate w/o trig.
```

The storage rate indicates the interval how often the measured values are transmitted or stored.

- Select in the scroll list a storage rate intended to store the measured values in case the event does not occur.
- Press ENTER.
- Select *Off* if no measured values are to be stored, as long as the event does not occur.
- Press ENTER.

```
Special functions\Data logger\Configuration\Start storing\Event-based\
Storage rate (trig.)
```

- Select in the scroll list a storage rate intended to store the measured values in case the event occurs.
- Press ENTER.

```
Special functions\Data logger\Configuration\Start storing\Event-based\Buffer time ->Π
```

- Enter the time interval for the measured values to be stored before occurring the event.
- Press ENTER.

```
Special functions\Data logger\Configuration\Start storing\Event-based\Buffer time Π->
```

- Enter the time interval for the measured values to be stored if the event is no longer active.
- Press ENTER.

Storage rate

```
Special functions\Data logger\Configuration\Storage rate
```

The storage rate is the frequency to transmit or store measured values. If a start time for storing the measured values is defined, a storage rate has to be entered.

- Select the menu item `Configuration`.
- Press ENTER until the menu item `Storage rate` is displayed.
- Select a storage rate from the scroll list.
- Press ENTER.
- If `Customized` is selected, enter the storage rate.
- Press ENTER.

Storage rate of the FastFood mode

The the storage rate of the FastFood mode is the frequency at which the measured values are stored in the FastFood mode.

```
Special functions\Data logger\Configuration\Storage rate FastF
```

This display will only be indicated if the FastFood mode has been activated in the menu item `Special functions\Measurement\Measurement modes`.

- Select the menu item `Configuration`.
- Press ENTER until the menu item `Storage rate FastF` is displayed.
- Select `Automatic` if the storage rate has to correspond to the value of the FastFood measuring rate.
- Press ENTER.
- Select `Customized` if the value for the storage rate is to be defined.
- Press ENTER.
- Enter a value.
- Press ENTER.

Ringbuffer

Special functions\Data logger\Configuration\Ringbuffer

The data logger can be configured as linear logger or ringbuffer. If the ringbuffer is deactivated and the data logger is full, the storing of measured values will be terminated. It can be continued after clearing the data logger. If the ringbuffer is activated and the data logger is full, the oldest measured values will be overwritten. In ringbuffer mode, the remaining capacity of the data logger is displayed during the measurement, e.g.:

"Log←→ : 1d 6h 57m" is displayed, if no measured values have been overwritten.

"Log|←→ : 1d 6h 57m" is displayed, if the old measured values have been overwritten.

- Select the menu item `Configuration`.
- Press ENTER until the menu item `Ringbuffer` is displayed.
- Select `On` to activate the ringbuffer.
- Press ENTER.

If the ringbuffer is deactivated and the data logger is full, the storing of measured values will be terminated.

- Select `Off` to deactivate the ringbuffer.
- Press ENTER.

Storage mode

Special functions\Data logger\Configuration\Storage mode

- Select the menu item `Configuration`.
- Press ENTER until the menu item `Storage mode` is displayed.
- Press ENTER.
- Select `Sample` to store the current measured value.
- Select `Average` if the average of all undamped measured values of a storage interval is to be stored.

Notice!

The storage mode does not affect the outputs.

Notice!

Storage mode = Average

The average of the physical quantity and other quantities assigned to the measuring channel, e.g., the measured temperature, will be calculated.

If the storage rate < 5 s is selected, `Sample` will be used.

If no average could be calculated over the complete storage interval, the value will be marked as invalid.

Further parameters for storing

For the following parameters it can be defined whether these are to be stored together with the measured values.

Tab. 16.1: Parameters for storing

display	description of the parameters
Store totalizers	values of the totalizers
Store diagnost. values	diagnostic values
Store transd. temp.	transducer temperature

- Select `Yes` to store the value. Select `No` in order not to store the value.

Acoustic signal during the storing

Special functions\Data logger\Configuration\Beep on storage

The storing of each measured value can be acoustically signaled. The signal can be activated or deactivated in the menu `Beep on storage`.

- Select `On` to activate the acoustic signal. Select `Off` to deactivate the acoustic signal.
- Press ENTER.

16.2 Deletion of the data logger

Special functions\Data logger>Delete meas. values

- Select the menu item `Special functions\Data logger>Delete meas. values`.
- Press ENTER.
- Select `Yes` or `No`.
- Press ENTER.

16.3 Information regarding the data logger

Special functions\Data logger\Data logger info

- Select the menu item `Data logger info`.
- Press ENTER.

The following information regarding the data logger is displayed:

display	description
Activated	data logger is activated/deactivated This display will only be indicated if the measurement has started and the data logger is activated.
Full (date)	date on which the data logger will be full This display will only be indicated if the measurement has started and the ringbuffer is deactivated.
Full (time)	time at which the data logger will be full This display will only be indicated if the measurement has started, the ringbuffer is deactivated and the data logger is not full yet.
Overflow (date)	date from which the oldest measured values will be overwritten This display will only be indicated if the measurement has started, the ringbuffer is activated and the data logger is not full yet.
Capacity (time)	remaining data logger capacity This display will only be indicated if the measurement has started and the ringbuffer is activated.
Ringbuffer	ringbuffer is activated/deactivated
Meas. val. Series	number of stored series of measured values
Occup. Logger	percentage of memory actually used

16.4 Print of measured values

- Start the terminal program.
- Enter the transmission parameters into the terminal program. The transmission parameters of the terminal program and the transmitter have to be identical.

```
Special functions\Data logger\Print meas. values
```

- Select the menu item `Print meas. values`.
- This display will only be indicated if the transmitter has an interface RS485.
- Press ENTER.

16.5 Transmission settings

```
Special functions\Data logger\Transmission settings\Serial output channel
```

- Select the menu item `Transmission settings`.
- This display will only be indicated if the transmitter has an interface RS485.
- Press ENTER.
- The channels for the serial transmission can be activated and deactivated.

- : the channel is activated
- : the channel is deactivated

- Select a channel with key `<4>` or `<6>`.
- Press `<2>` or `<8>` to activate or deactivate the channel.
- Press ENTER.

```
Special functions\Data logger\Transmission settings>Delete spaces
```

- Select `On` if the space characters are not to be transmitted.
 - Press ENTER.
- The file size will be considerably reduced (shorter transmission time).

```
Special functions\Data logger\Transmission settings\Decimal marker
```

- Select the decimal marker to be used for floating-point numbers (point or comma).
 - Press ENTER.
- This setting depends on the setting of the operating system of the PC.

```
Special functions\Data logger\Transmission settings\Column separator
```

- Select the character to be used to separate columns (semicolon or tabulator).
- Press ENTER.

```
Special functions\Data logger\Transmission settings>Date/time
```

- Select `Yes` to transmit time and date.
- Press ENTER.

17 Data transmission

The data is transmit to the transmitter via service or process interfaces (optional).

17.1 Service interfaces

By means of the program FluxDiagReader it is possible to transmit via service interfaces (USB, LAN) data to the PC.

The following tasks can be carried out:

- read and store measured values, setup settings and snaps
- graphically display measured value
- export of data in csv format

For the operation of the program see FluxDiagReader support.

17.1.1 LAN interface

In order to use the LAN interface it is important to enter the network parameters.

- Select the program branch `Special functions`.
- Press ENTER.

```
Special functions\Communication\Network
```

- Select the menu item `Special functions\Communication\Network`.
- Press ENTER.

Manual input

- Select `Manual` to enter the network parameter (IP address, subnet mask and standard gateway).

Notice!

The entered network parameter has to accord with the network parameters of the LAN.

default value in the transmitter:

- IP address: 192.168.0.70
- subnet mask: 255.255.255.0
- standard gateway: 192.168.0.1

Automatic addressing with DHCP

- Select `Automatic` to automatically identify the network parameter (IP address, subnet mask and gateway address) via a DHCP server.

Notice!

The network parameters can only be automatically identified if the LAN supports DCHP.

- Select the menu item `Special functions\Communication\Network>Show auto config`. to display the identified network parameters.
- Press ENTER.

Notice!

The program FluxDiag is used to transmit data from the PC to the transmitter.

17.2 Process interface

The transmitter can be equipped with a process interface (e.g., Profibus, Modbus). For the connection of the process interfaces to the transmitter see supplement to operating instruction.

RS485 interface

```
Special functions\Communication\RS485
```

- Select the menu item RS485 to change the settings of the transmission parameters.
- Press ENTER.

This display will only be indicated if the transmitter has an interface RS485.

default: 9600 bit/s, 8 data bits, no parity, 1 stop bit

- Set the transmission parameters in the scroll lists.
 - Baud (baud rate)
 - Data bits
 - Stop bits
 - Parity
 - Data flow control
- Press ENTER.

```
Special functions\Communication\Info RS485
```

The terminals for the connection of the RS485 interface are displayed.

- Press ENTER.

18 Advanced functions

18.1 Totalizers

The total volume or total mass of the fluid at the measuring point can be determined.

There are 2 totalizers, one for the positive and the other for the negative flow direction. The unit of measurement used for totalizing corresponds to the volume or mass unit selected for the physical quantity.

The totalizer values can be displayed in the status line during the measurement.

Tab. 18.1: Key functions

totalizer display	press $\boxed{8}$ during the measurement
freezing of the displayed totalizer value	press $\boxed{8}$ for at least 2 s during the measurement
display of the flow totalizer for the positive flow direction	press $\boxed{6}$ during the measurement
display of the flow totalizer for the negative flow direction	press $\boxed{4}$ during the measurement
reset of the totalizers to zero	press $\boxed{2}$ 3 times during the measurement totalizing will be restarted after pressing the key $\boxed{8}$
	press $\boxed{8}$ 3 times during the measurement totalizing will be restarted and displayed immediately

Notice!

The pressing of a key will only influence the flow totalizers of the measuring channel whose measured values are currently displayed.

18.1.1 Number of decimal places

The values of the totalizers can be displayed with up to 11 places, e.g., 74890046.03. The number of decimal places (max. 4) can be defined.

Special functions\Totalizers

- Select the menu item `Totalizers` in the program branch `Special functions`.
- Press `ENTER`.
- Select `Automatic` if the number of decimal places has to be adjusted automatically.
- Press `ENTER`.

Low totalizer values will initially be displayed with 3 decimal places. If the values of the totalizers are higher, the number of decimal places will be reduced.

max. value	display
$< 10^6$	±0.000 ... ±999999.999
$< 10^7$	±1000000.00 ... ±9999999.99
$< 10^8$	±10000000.0 ... ±99999999.9
$< 10^{10}$	±1000000000 ... ±9999999999

- Select the number of decimal places.
- Press `ENTER`.

The number of decimal places is constant. The max. value of the totalizers decreases with the number of decimal places.

decimal places	max. value	max. display
0	$< 10^{10}$	±9999999999
1	$< 10^8$	±99999999.9
2	$< 10^7$	±9999999.99
3	$< 10^6$	±999999.999
4	$< 10^5$	±99999.9999

Notice!
 The number of decimal places and the max. value of the totalizers only affect the display.

18.1.2 Detection of long measurement failures

If there are no valid measured values during a long time interval, the totalizers remain unchanged. The time interval can be defined.

```
Special functions\Totalizers\Totalizer timeout
```

- Select the menu item `Totalizers` in the program branch `Special functions`.
- Press ENTER until the menu item `Totalizer timeout` is displayed.
- Select `Default` if no customized inputs are to be carried out and the default value of 30 s is to be used.
- Press ENTER.
- Select `Customized` if the time interval is to be defined.
- Press ENTER.
- Enter the time interval.
- Press ENTER.

18.1.3 Totalizer overflow

The overflow behavior of the totalizers can be set:

Without overflow

- The value of the totalizer increases to the internal limit of 10^{38} .
- The values will be displayed as exponential numbers ($\pm 1.00000E10$), if necessary. The flow totalizer can only be reset to zero manually.

With overflow

The flow totalizer will be reset to zero automatically when ± 9999999999 is reached.

```
Special functions\Totalizers\Overflow behavior
```

- Select the menu item `Totalizers` in the program branch `Special functions`.
- Press ENTER until the menu item `Overflow behavior` is displayed.
- Select `Yes` to work with overflow. Select `No` to work without overflow.
- Press ENTER.

Independent of the setting, the flow totalizers can be reset to zero manually.

Notice!
 The overflow of a totalizer influences all output channels, e.g., data logger, online transmission of data. The output sum of both totalizers (throughput ΣQ) transmitted via an output is no longer valid after the overflow of one of the totalizers.

18.1.4 Totalizer behavior after the measurement is stopped

It is possible to define the totalizer behavior after the measurement is stopped or after a reset of the transmitter.

```
Special functions\Totalizers\Keep totalizers
```

- Select the menu item `Totalizers` in the program branch `Special functions`.
- Press ENTER until the menu item `Keep totalizers` is displayed.
- Select `Yes` if the values of the flow totalizers are to be stored and used for the next measurement. Select `No` if the totalizers are to be set to zero.
- Press ENTER.

18.1.5 Totalizer sum

The sum of the totalizers for both flow directions can be displayed in the status line during the measurement.

```
Special functions\Totalizers\Show ΣQ
```

- Select the menu item `Totalizers` in the program branch `Special functions`.
- Press ENTER until the menu item `Show ΣQ` is displayed.
- Select `Yes` to display the totalizer sum. Select `No` if it is not to be displayed.
- Press ENTER.

18.1.6 Totalizer storing

The totalizer values can be stored now.

- Select the menu item `Special functions\Data logger\Configuration`.
- Press ENTER until the menu item `Store totalizers` is displayed.
- Select `Yes`.
- Press ENTER.

18.2 FastFood mode

The FastFood mode allows to measure highly dynamic flows. A continuous adaptation to changing measuring conditions is only partially realized in the FastFood mode.

- The sound speed of the fluid is not updated. The last measured value of the sound speed before toggling to the FastFood mode is used.
- It is not possible to change the measuring channel. The measurement takes place on one channel only. As long as the FastFood mode is activated, no measurement is carried out on the other channels.
- The outputs of the channel activated in FastFood mode can still be used. They are updated synchronously with the FastFood measuring rate, independently from the storage rate.
- Outputs for further channels (multi-channel measurement) transmit an error value.
- The measured values are stored with the storage rate of the FastFood mode.
- The FastFood mode has to be enabled and activated.

18.2.1 Enabling/disabling the FastFood mode

```
Special functions\Measurement\Measurement modes\Enable FastFood
```

- Select the menu item `Special functions\Measurement\Measurement modes`.
- Press ENTER until the menu item `Enable FastFood` is displayed.
- Select `On` to enable the FastFood mode, to disable it. Select `Off` to disable it.
- Press ENTER.

If `On` is selected, the menu item `Measuring rate FastF` is displayed. The FastFood measuring rate indicates in which interval the measured values are transmitted to the process outputs.

- Select `Default` if no customized inputs are to be made. The default value is 50 ms.
- Select `Customized` if a value for the FastFood measuring rate is to be entered.
- Enter a value within the range 10...200 ms.
- Press ENTER.

18.2.2 Storage rate of the FastFood mode

The storage rate for the FastFood mode is entered during the configuration of the data logger in the menu item `Storage rate FastF`.

`Special functions\Data logger\Configuration\Storage rate FastF`

- Select the menu item `Special functions\Data logger\Configuration`.
- Activate the channels whose measured values have to be stored.
- Press ENTER until the menu item `Storage rate FastF` is displayed.
- Select `Automatic` if the storage rate has to correspond to the value of the FastFood measuring rate.
- Press ENTER.
- Select `Customized` if the value for the storage rate is to be defined.
- Press ENTER.
- Enter a value.
- Press ENTER.

18.2.3 Activation/deactivation of the FastFood mode

If the FastFood mode is enabled and a measurement is started, the normal measuring mode will still be running.

- Press `0` to activate the FastFood mode for the measuring channel currently displayed. The symbol for the FastFood mode  appears in the upper line.
- Press `0` to deactivate the FastFood mode.

The FastFood mode can be activated/deactivated via remote functions.

18.3 Calculation channels

Notice!

Calculation channels are only available if the transmitter has more than one measuring channel.

In addition to the ultrasonic measuring channels, the transmitter has 2 virtual calculation channels Y and Z which calculate the measured values of all measuring channels.

The result of the defined calculation function is the measured value of the selected calculation channel. This measured value is equivalent to the measured values of a measuring channel. All operations which are possible with the measured values of a measuring channel (totalizing, storing, outputs, etc.) can also be done with the measured values of a calculation channel.

18.3.1 Characteristics of the calculation channels

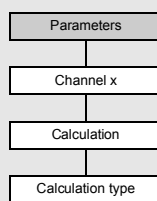

see annex A

The measuring channels to be used for calculation and the calculation function have to be entered in the program branch `Parameters`.

It is possible to define 2 cut-off flows for each calculation channel. The cut-off flow is not based on the flow velocity as is the case with the measuring channels. Instead, it is defined in the unit of measurement of the physical quantity selected for the calculation channel. During the measurement, the calculation values are compared with the cut-off values and set to zero, if necessary.

18.3.2 Parameterization of a calculation channel

`Parameters\Channel Y`

- Select a calculation channel (here: `Channel Y`) in the program branch `Parameters`.
- Press ENTER.

The current calculation function is displayed.

- Press ENTER.

18.3.2.1 Selection of the calculation type

Tab. 18.2: Calculation types

average (all chan. OK)	average (1 chan. OK)	special
mean with "AND" All measuring channels have to deliver a valid measuring value. calculation function: $Y = (A + B) / 2$	mean with "OR" At least one measuring channel has to deliver a valid measuring value. calculation function: $Y = (A + B) / n$	Each channel selected for calculation can be assigned with a signed value.

```
Parameters\Channel Y\Calculation type
```

- Select a calculation type.
- Press ENTER.
- Assign a measuring channel to each source channel.
- Press ENTER after each selection.

Example

```

calculation type:          special
source channel 1:         Meas. Channel A
sign source channel 1:    |A|
source channel 2:         Meas. Channel B
sign source channel 2:    |B|
average:                  1/2 (AND)
linear correction:        Yes
factor:                   1.5 Factor
offset:                   2.0 m/s

calculation function:     1.5 * (|A|+|B|)/2 + 2 m/s

```

18.3.2.2 Input of limits

It is possible to define limits for the physical quantity for each calculation channel. They are entered in the unit of measurement of the physical quantity selected for the calculation channel.

```
Parameters\Channel Y\Calculation type\+Upper limit
```

- Select `No limit` if the calculation channel has to output all positive values without upper limit.
- Press ENTER.
- Select `Set to limit` if the calculation channel has to output the limit when exceeding the upper limit.
- Press ENTER.
- Select `Set to error` if the calculation channel has to output an error (`UNDEF`) when exceeding the upper limit.
- Press ENTER.

```
Parameters\Channel Y\Calculation type\~Upper limit
```

- Select `No limit` if the calculation channel has to output all negative values without upper limit
- Press ENTER.
- Select `Set to limit` if the calculation channel has to output the limit when falling below the upper limit.
- Press ENTER.
- Select `Set to error` if the calculation channel has to output an error (`UNDEF`) when falling below the upper limit.
- Press ENTER.

It is possible to define 2 cut-off flows for each calculation channel. They are entered in the unit of measurement of the physical quantity selected for the calculation channel.

```
Parameters\Channel Y\Calculation type\+Cut-off flow
```

- Enter a value for the positive cut-off flow.
- Press ENTER.

All positive calculated values less than the limit are set to zero.

```
Parameters\Channel Y\Calculation type\-Cut-off flow
```

- Enter a value for the negative cut-off flow.
- Press ENTER.

All negative calculated values that are greater than the limit are set to zero.

18.3.3 Output options for a calculation channel

- Select the program branch `Options`.
- Press ENTER.

```
Options\Channel
```

- Select a calculation channel for which the physical quantity is to be entered.
- Press ENTER.
- Select `Measurement`.
- Press ENTER.

```
Options\Measurement\Physical quantity
```

- Select a physical quantity which is to be transmitted via the calculation channel.
- Press ENTER.

For the selected physical quantity (except sound speed), a scroll list with the available units of measurement is displayed. The unit of measurement which was selected previously is displayed first.

- Select the unit of measurement of the physical quantity.
- Press ENTER.

```
Options\Measurement\Damping
```

- Enter the damping factor.

If the damping factor for the measuring channels A or B has already been entered in the program branch `Options`, enter the value zero.

- Press ENTER.

18.3.4 Measurement with calculation channels

- Select the program branch `Measurement`.
- Press ENTER.

```
Measurement>Select channels
```

- Activate the necessary channels. The calculation channels are activated or deactivated the same way as measuring channels.
- Press ENTER.

Notice!

If a measuring channel that is needed for an activated calculation channel is deactivated, no value is output for the calculation channel.

18.3.5 Advanced diagnosis

An advanced diagnosis is available for the calculation channels in the ExperUser, SuperUser and SuperUser ext. mode. It serves to detect errors on individual measuring channels. The values of the advanced diagnosis can either be transmitted via the outputs of the transmitter or defined as source of the event trigger.

Selection of the calculation channel

```
Options\Channel Y
```

- Select the program branch `Options`.
- Press ENTER.
- Select the calculation channel (here: `Channel Y`).
- Press ENTER.

Assignment of an output

- Select `Outputs`.
- Press ENTER.

```
Options\Channel Y\Outputs\Current I1(--)
```

- Select the output to be assigned to the calculation channel (here: `Current I1(--)`).
- Press ENTER.

The scroll list contains all available outputs of the transmitter:

```
- Current Ix (--)
- Binary Bx (--)
```

If the output has already been assigned to a channel, it is displayed as follows: `Current I1 (Y)`.

```
Options\Channel Y\Outputs\Current I1\I1 Enable
```

- Select `Yes` to change the settings for an already assigned output or to assign a new output.
- Select `No` to cancel the assignment and to return to the previous menu item.
- Press ENTER.

One source item has to be assigned to each selected output.

```
Options\Channel Y\Outputs\...\Source item
```

- Select `Extended diagnost. as source item`.
- Press ENTER.
- Select a list item for the quantity to be output.
- Press ENTER.

Tab. 18.3: Source item Extended diagnost.

source item	list item	output
Extended diagnost.	Valid channels	percentage of physical channels, with valid measuring state
	σ (Sound speed)	standard deviation of the sound speed
	σ (Flow velocity)	standard deviation of the flow velocity
	σ (Amplification)	standard deviation of the signal amplification
	σ (Amplitude)	standard deviation of the signal amplitude
	σ (Quality)	standard deviation of the signal quality
	σ (SNR)	standard deviation SNR
	σ (SCNR)	standard deviation SCNR
	σ (VariAmp)	standard deviation of the amplitude fluctuation
σ (VariTime)	standard deviation of transit time fluctuation	

The list item `Valid channels` will not be displayed if a binary output was selected as output.
 The status of a standard deviation is OK if a measured value for calculation is available on at least 2 measuring channels.

Definition of an event trigger

Options\Channel Y

- Select a calculation channel in the program branch `Options`, for which an event trigger is to be enabled (here: `Channel Y`).
- Press ENTER.
- Select the menu item `Event trigger`.
- Press ENTER.

Options\Channel Y\Event trigger\Rx(-)

- Select the event trigger.
- If the event trigger has already been enabled, it is displayed as follows: `R1(+)`

Options\Channel Y\Event trigger\Rx Enable

- Select `Yes` to change the settings for an already assigned event trigger or to assign a new one.
- Select `No` to cancel the assignment and to return to the previous menu item.
- Press ENTER.

Options\Channel Y\Event trigger\Rx Enable\Source item

- Select the source item `Extended diagnost`.
- Press ENTER.
- Select the list item for which a condition is to be defined.
- Press ENTER.

18.4 Diagnosis with the help of the snap function

18.4.1 Configuration

By means of the snap function it is possible to store measuring parameters which are useful for the evaluation of measuring results or diagnostic purposes. To make use of the snap function it has to be configured.

```
Special functions\Snap\Configuration
```

- Select the menu item Configuration.
- Press ENTER.

```
Special functions\Snap\Configuration\Snap
```

- Select On to activate the snap function.
- Press ENTER.

```
Special functions\Snap\Configuration\Snap ringbuffer
```

- Select Yes to activate the snap ringbuffer.

If the snap ringbuffer is activated, after taking the 51th, snap the oldest snaps are overwritten. The oldest snaps will be overwritten. If the ringbuffer is deactivated, up to 50 snaps can be stored.

- Press ENTER.

```
Special functions\Snap\Configuration\Auto snap
```

- Select Yes if the auto snap has to be activated.

If the auto snap is activated, snaps are automatically stored during a measurement failure.

- Press ENTER.

```
Special functions\Snap\Configuration\Snap on R1
```

- Select Yes if an event has been parameterized on the event trigger R1 which, at time of occurrence, has to release a snap.
- Press ENTER.

18.4.2 Information concerning snaps

```
Special functions\Snap\Snap info
```

- Select the menu item Snap info.
- Press ENTER.

The following information are displayed:

display	description
Stored snaps	number of stored snaps
Snaps left	number of snaps that can still be stored
Ringbuffer	snap ringbuffer activated

18.4.3 Deletion of snaps

Special functions\Snap>Delete snaps

- Select the menu item `Delete snaps`.
- Press ENTER.
- Select `Yes` or `No`.
- Press ENTER.

18.5 Modification of the limit for the inner pipe diameter

It is possible to modify the lower limit of the inner pipe diameter for a given transducer type.

- Select the program branch `Special functions`.
- Press ENTER.

Special functions\Pipe diameter MIN

- Select `Pipe diameter MIN`.
- Press ENTER.

It is possible to define a min. pipe diameter for all relevant transducer frequencies.

- Select `Default` if no customized inputs are to be made and the default values are to be used.
- Press ENTER.
- Select `Customized` if a min. pipe diameter is to be defined.
- Press ENTER.
- Enter the pipe diameter in mm.
- Press ENTER.

Notice!

If a transducer is used below its recommended inner pipe diameter, a measurement might be impossible.

18.6 Remote functions

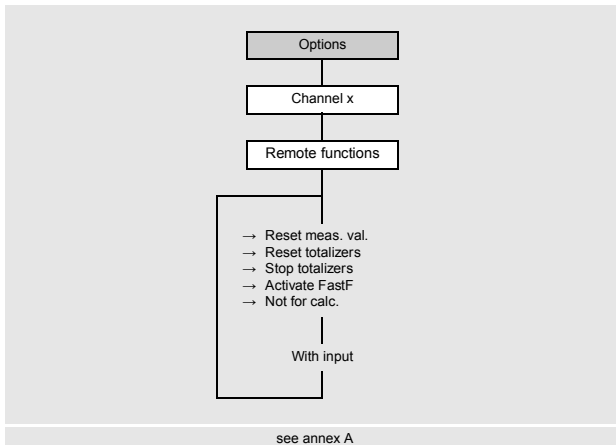

Remote functions can be released via event triggers, triggerable analog or binary inputs.

In order to define a remote function for an input, it has to be enabled in the menu item `Special functions\Inputs`.

In order to define a remote function for an event trigger, it has to be activated in the program branch `Options\Channel x\Event trigger`.

It is possible to trigger one or more remote functions for different channels.

The following remote functions can be triggered:

- reset of measured values
- reset totalizers
- stop totalizers
- activation of the FastFood mode
- not for calculation

Event trigger

The remote function is triggered if the switching condition is fulfilled. The remote function is reset as soon as the switching condition is no longer met.

18.6.1 Configuration of the remote function

The remote function can be configured for each individual channel.

```
Options\Channel x\Remote functions
```

- Select the measuring channel in the program branch `Options` for which a remote function is to be activated.
- Press ENTER.
- Select the menu item `Remote functions`.
- Press ENTER.

In the scroll list of the functions it is displayed whether the function is assigned and if yes with which input or event trigger it is defined.

- Select a list item:

```
- Reset meas. val. (-)
- Reset totalizers (-)
- Stop totalizers (-)
- Activate FastF (-)
- Not for calc. (-)
```

If this function has already been assigned to an input or event trigger, it is displayed as follows: `Reset meas. val. (R1)`.

- Press key  to return to the previous menu.

Notice!

The settings made are stored at the beginning of a measurement.

Reset of measured values

- Select the list item `Reset meas. val.`
- Press ENTER.

The measured value output simulates a reposing application for the duration of the signal. The actual measured flow velocity is ignored and the measured value is set to zero. All values of the physical quantity derived from the flow velocity and the values from the calculation channels also yield to zero.

The transmitter continues the measurement if the condition of the remote function is no longer met.

- Select the input which is to be used to trigger the selected remote function.
- Press ENTER.
- Select `No linkage` in order to deactivate the remote function.
- Press ENTER.

Reset of the totalizers

- Select the list item `Reset totalizers.`
- Press ENTER.

The totalizers are set to zero.

Totalizing starts at zero again, as soon as the condition for the remote function is no longer met.

When the totalizers are reset to zero with the remote function, the character `H` is displayed next to the measured value during the measurement.

- Select the input which is to be used to trigger the selected remote function.
- Press ENTER.
- Select `No linkage` in order to deactivate the remote function.
- Press ENTER.

Stop of the totalizers

- Select the list item `Stop totalizers.`
- Press ENTER.

The totalizers are stopped for the duration of the signal.

Totalizing will be continued with the last registered totalizer value if the condition of the remote function is no longer met.

- Select the input which is to be used to trigger the selected remote function.
- Press ENTER.
- Select `No linkage` in order to deactivate the remote function.
- Press ENTER.

Activation of the FastFood mode

- Select the list item `Activate FastF.`
- Press ENTER.

The FastFood mode is activated for the duration of the signal. It is deactivated as soon as the condition for the remote function is no longer met.

This list item is only available for measuring channels and only appears if the FastFood mode was activated in menu item `Special functions\Measurement\Measurement modes\FastFood.`

- Select the input which is to be used to trigger the selected remote function.
- Press ENTER.
- Select `No linkage` in order to deactivate the remote function.
- Press ENTER.

Not for calculation

This function enables the user to define an event-based channel selection for calculation channels.

- Select the list item `Not for calc..`
- Press ENTER.

If the condition for the remote function is met, this measuring channel will not be calculated in the calculation channel. The measurement on the measuring channel continues running. The source of this remote function can be an event trigger or a process input.

The measuring channel is available again for the calculation channel, if the condition for the remote function is no longer met.

- Select the input which is to be used to trigger the selected remote function.
- Press ENTER.
- Select `No linkage` in order to deactivate the remote function.
- Press ENTER.

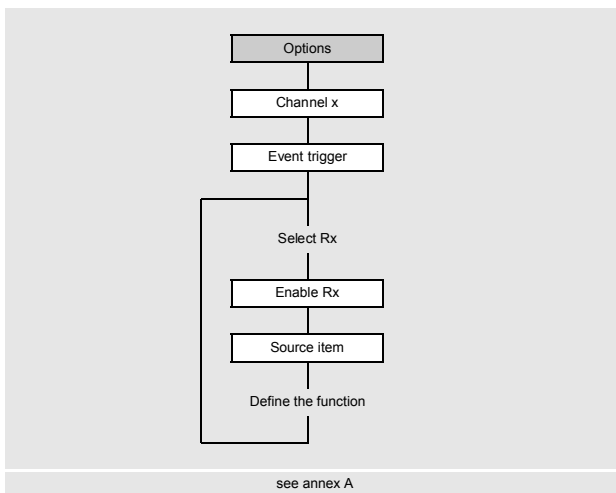
18.7 Event trigger

It is possible to configure max. 4 independent event trigger R1, R2, R3, R4 per channel.

The event trigger can be used to:

- output information about the ongoing measurement
- trigger special remote functions
- switch on/off pumps and motors
- Select the program branch `Options`.
- Press ENTER.

```
Options\Channel x\Event trigger\Rx(-)
```

- Select the event trigger.

If an event trigger has already been installed, it is displayed as follows: `Rx (+)`.

```
Options\Channel x\Event trigger\Rx Enable
```

- Select `Yes` to change the settings for an already assigned event trigger or to assign a new one.
- Select `No` to cancel the assignment and to return to the previous menu item.
- Press ENTER.

```
Options\Channel x\Event trigger\Rx Enable\Source item
```

- Select the source item (physical quantity) for which a condition has to be defined.

Tab. 18.4: Source item

source item	list item	output
Flow quantities	Flow velocity Volumetric flow rate Mass flow rate	flow velocity volumetric flow rate mass flow rate
Totalizers	Volume (+) Volume (-) Volume (Δ) Mass (+) Mass (-) Mass (Δ)	totalizer for the volumetric flow rate in positive flow direction totalizer for the volumetric flow rate in negative flow direction difference of the totalizers for the positive and negative flow direction totalizer for the mass flow rate in positive flow direction totalizer for the mass flow rate in negative flow direction difference of the totalizers for the positive and negative flow direction
Diagnostic values	Amplitude Quality SNR SCNR VariAmp VariTime Amplification PIG detection	signal amplitude signal quality ratio useful signal/noise signal ratio of useful signal and correlated noise signal amplitude fluctuation transit time fluctuation amplification, important to receive a useful signal signals whether a pig is detected This display will only be indicated if PIG detection is activated.
Miscellaneous	Custom. Input 1 Custom. Input 2 Custom. Input 3 Custom. Input 4	measured values of input quantities (e.g., temperature, density) which are not used for calculation In the menu item Options\Assign inputs it is possible to assign configured inputs to customized inputs.
Sound speed	Sound speed Sound speed (Δ)	measured sound speed in the fluid difference of the measured sound speed and the sound speed calculated from the fluid data

Afterwards the properties of the event trigger are defined.

Tab. 18.5: Properties of the event trigger

property event trigger	setting	description
Function (switching condition)	MAX (x>limit)	The event trigger will switch if the measured value exceeds the upper limit.
	MIN (x<limit)	The event trigger will switch if the measured value falls below the lower limit.
	ERR (x=fail)	The event trigger will switch if a measurement is not possible.
	Within range	The event trigger will switch if the measured value is within the defined range.
	Out of range	The event trigger will switch if the measured value is outside the defined range.
Type (holding behavior)	Non-hold	If the switching condition is no longer met, the event trigger will return to the idle state after approx. 1 s.
	Hold	The event trigger remains activated even if the switching condition is no longer met.
	Hold for a while	The event trigger remains activated during a defined time even if the switching condition is no longer met.

Definition of the switching condition

```
Options\Event trigger\Rx Enable\Source item\...\Function
```

- Select the switching condition.
- Press ENTER.

Definition of the holding behavior

```
Options\Event trigger\Rx Enable\Source item\...\Type
```

- Select the type of the holding behavior.
- Press ENTER.

Definition of trigger limits

```
Options\Event trigger\Rx Enable\Source item\...\Trigger value
```

It is important to enter the limits, when the event trigger have to toggle.

- Enter the upper limit MAX (x>limit).
- Press ENTER.
- Enter the lower limit MIN (x<limit).
- Press ENTER.

```
Options\Event trigger\Rx Enable\Source item\...\Hysteresis
```

It is possible to define a hysteresis to avoid a constant switching of the event trigger.

The event trigger will be activated if the measured values exceed the upper limit. It will be deactivated if the measured values fall below the lower limit.

- Enter the value for the hysteresis.
- If zero is entered, no hysteresis is used.
- Press ENTER.

Example

```
MAX (x>limit): 30 m³/h  
Hysteresis: 1 m³/h
```

The event trigger is activated for measured values > 30.5 m³/h and deactivated for measured values < 29.5 m³/h.

```
Options\Event trigger\Rx Enable\Source item\...\Range center
```

- Enter the value for the range center in which the event trigger has to be switched.
- Press ENTER.

```
Options\Event trigger\Rx Enable\Source item\...\Range width
```

- Enter the value for the range width in which the event trigger has to be switched.
- Press ENTER.

Example

```
Function: Out of range  
Range center: 100 m³/h  
Range width: 40 m³/h
```

The event trigger will switch if the measured value is below 80 m³/h or above 120 m³/h.

Definition of the switching delay

```
Options\Event trigger\Rx Enable\Source item\...\Glitch interval
```

- Enter a time interval after which the event trigger has to switch in case an event occurred.
- Press ENTER.

```
Options\Event trigger\Rx Enable\Source item\...\Failure delay
```

- Enter a time interval after which the event trigger has to be deactivated in case of a measurement failure.
- Press ENTER.

18.7.1 Apparent switching delay

The measured values and totalizer values will be displayed rounded according to the set number of decimal places. The limits, however, will be compared to the non-rounded measured values. This might cause an apparent switching delay when the measured value changes marginally (less than the visualized decimal places). In this case, the switching accuracy of the event trigger is higher than the accuracy of the display.

18.7.2 Reset and initialization of the event trigger

After an initialization of the transmitter all event triggers are deactivated.

- Press 3 times key C during measurement to set all event trigger to the idle state.

Event trigger whose switching condition is still met will be activated again after 1 s. This function is used to reset event trigger of the type HOLD if the switching condition is no longer met.

If a measurement is stopped, all event trigger will be de-energized, independently of the programmed idle state.

18.7.3 Event trigger during the measurement

An event trigger with the switching condition MAX ($x > \text{limit}$), MIN ($x < \text{limit}$), Within range or Out of range will be updated max. once per second to avoid a constant switching of the event trigger (i.e. fluctuation of the measured values around the value of the switching condition).

An event trigger with switching condition ERR ($x = \text{fail}$) will be activated during a measurement failure.

An event trigger of the type Non-hold will be activated if the switching condition is met. It will be deactivated if the switching condition is no longer met. The alarm remains activated for at least 1 s even if the switching condition is met for a shorter period of time.

An event trigger of the type Hold will be activated if the switching condition is met. It remains activated even if the switching condition is no longer true.

An event trigger of the type Hold for a while will be activated if the switching condition is met. In the menu item Hold interval the time is defined when deactivation takes place.

18.7.4 Status display of the event trigger

Notice!
There is no visual or acoustic indication of event trigger switching.











The state of the event trigger is displayed during the measurement.

- Press key 9 to scroll through the second line from below until the event trigger status is displayed.

The status display of the event trigger is structured as follows.

Rx = with x being the number of the event trigger and a pictogram according to Tab. 18.6.

Tab. 18.6: Pictograms for the status display of the event trigger

	No.		Function (switching condition)	Type (holding behavior)	current state
R		=			
	1		 MAX ($x > \text{limit}$)	 Non-hold	 closed
	2		 MIN ($x < \text{limit}$)	 Hold	 open
	3		 Within range	 Hold for a while	
	4		 Out of range		
			 ERR ($x = \text{fail}$)		

Example



R1 =   

18.8 Event protocol

If an error occurs, an error message will be displayed in the first line indicating the symbol . The error message can be displayed via the menu item `Event log`.

`Special functions\System settings\Event log`

- Select the menu item `Event log`.
 - Press ENTER.
- A list is displayed containing all error messages since the last time the transmitter was switched on.

- Press the keys  and  to select an error message.
- Press ENTER.

The display indicates the cause of the error.

Notice!

After reading out the event protocol the error message symbol will be deleted on the display, even the error has not been eliminated yet.

The event protocol will be deleted after a restart of the transmitter.

19 Settings

19.1 Dialogs and menus

Special functions\Dialogs/Menu

- Select the menu item `Dialogs/Menu` in the program branch `Special functions`.
- Press ENTER.

Pipe circumference

Special functions\Dialogs/Menu\Pipe circumference

- Select the menu item `Pipe circumference`.
- Select `Yes` if the pipe circumference is to be entered instead of the pipe diameter in the program branch `Parameters`.
- Press ENTER.

If `Yes` is selected for `Pipe circumference`, the outer pipe diameter will be requested in the program branch `Parameters`.

- Press key to select the menu item `Pipe circumference`.
- Press ENTER.

The value displayed in the menu item `Pipe circumference` is calculated from the last displayed outer pipe diameter.

Example: 100 mm · π = 314.2 mm

- Enter the pipe circumference. The limits for the pipe circumference are calculated on the basis of the limits for the outer pipe diameter.
- Press ENTER.

During the next scroll through the program branch `Parameters`, the outer pipe diameter that corresponds to the entered pipe circumference will be displayed.

Example: 180 mm : π = 57.3 mm

Coating

If the pipe has a coating, the material parameters of the coating have to be entered in the program branch `Parameters`.

Special functions\Dialogs/Menu>Edit coating

- Select the menu item `Edit coating`.
- Select `Yes` if the pipe has a coating.
- Press ENTER.

Lining 2

If the pipe has a second lining, the material parameters of the coating have to be entered in the program branch `Parameters`.

Special functions\Dialogs/Menu>Edit Lining 2

- Select the menu item `Edit Lining 2`.
- Select `Yes` if the pipe has 2 linings.
- Press ENTER.

Measuring point number

Special functions\Dialogs/Menu\Measuring point no.

- Select the menu item `Measuring point no.`
- Select `Number` if the measuring point is to be identified only by numbers. Select `Text` if the measuring point is to be identified only by characters.
- Press ENTER.

Error delay

The error delay is the time after which an error value will be sent to an output if no valid measured values are available.

```
Special functions\Dialogs/Menus/Error value delay
```

- Select the menu item `Error value delay`.
- Select `Edit` to enter an error delay. Select `Damping` if the damping factor is to be used as the error delay.
- Press ENTER.

Transducer distance

```
Special functions\Dialogs/Menus/Transducer distance
```

- Select the menu item `Transducer distance`.
- Select `Customized` if the measuring point is always the same. Select `Automatic` if the measuring point often changes.
- Press ENTER.

In the program branch `Measurement`, the recommended transducer distance will be displayed in parenthesis, below the entered transducer distance.

Sound speed of the reference fluid

```
Special functions\Dialogs/Menus/Compare c fluid
```

- Select the menu item `Compare c fluid`.

Select `Yes` if the difference $\Delta c = c_{\text{mea}} - c_{\text{stored}}$ between the two sound speeds has to be displayed. c_{ref} is the calculated sound speed of the reference fluid at same process conditions (temperature, pressure).

`Compare c fluid` can also be activated or deactivated during the measurement and has an immediate effect on the display of the measured values.

- Press key `3` during the measurement to scroll to the display of Δc .

Display of the last value

```
Special functions\Dialogs/Menus/Display last value
```

- Select the menu item `Display last value`.
- Select `Yes` to display the last valid value.

If `Yes` is selected and no valid measured value can be displayed during the measurement, the channel will display the last valid value. Behind this value a question mark will be displayed.

Toggle time

The toggle time indicates the time interval after which the transmitter (operating in `AutoMux` mode) toggles between the different channels during the measurement. The default value is 3 s.

```
Special functions\Dialogs/Menus/Toggle time
```

- Select the menu item `Toggle time`.
- Enter a different toggle time value if the default value is no to be used.
- Press ENTER.

This value remains stored until a new toggle time is entered.

Switching off the display backlight

```
Special functions\Dialogs/Menus/Light autom. off
```

- Select `Yes` to activate the automatic switch-off.
- Press ENTER.

If the automatic switch-off of the display backlight is activated, the backlight is switched off after about 30 s. When pressing a key or connecting a USB cable, the backlight is switched on again.

19.2 Measuring modes

```
Special functions\Measurement\Measurement modes
```

- Select the menu item `Measurement` in the program branch `Special functions`.
- Press ENTER.
- Select the menu item `Measurement modes`.
- Press ENTER.

FastFood mode

```
Special functions\Measurement\Measurement modes\Enable FastFood
```

- Select `On` to enable the `FastFood` mode, to disable it. Select `Off` to disable it.
- Press ENTER.

19.3 Measurement settings

```
Special functions\Measurement\Measurement settings
```

- Select the menu item `Measurement` in the program branch `Special functions`.
- Press ENTER.
- Select the menu item `Measurement settings`.
- Press ENTER.

Multi-point calibration

A multi-point calibration allows a very precise output of measuring results. The basis for the multi-point calibration offer calibration curves of measurement series.

```
Special functions\Measurement\Measurement settings\Multi-point calibration
```

- Select the menu item `Multi-point calibration`.
- Select `On` to activate the multi-point calibration. Select `Off` to deactivate it.
- Press ENTER.
- Select `Default (Multi-point calibration = Off)` if no customized inputs are to be made.
- Press ENTER.

If `On` is selected, a series of measured values have to be entered in the program branch `Options`.

Swift damping

If `Swift damping` is activated, each displayed measured value is a floating average of the last x seconds, with x being the damping factor. The display thus takes x seconds to fully respond to flow rate changes.

If `Swift damping` is deactivated, the damping is calculated as first order low-pass filter, i.e. changes of measured values become effective in form of an exponential time course in the measuring result.

```
Special functions\Measurement\Measurement settings\Swift damping
```

- Select the menu item `Swift damping`.
- Select `On` to activate the swift damping. Select `Off` to deactivate it.
- Select `Default (Swift damping = On)` if no customized inputs are to be made.
- Press ENTER.

19.4 Units of measurement

It is possible to set the global units of measurement for length, temperature, pressure, sound speed, density and kinematic viscosity.

```
Special functions\Units of measurement
```

- Select the menu item `Units of measurement`.
- Press ENTER.
- Select a unit of measurement for all quantities.
- Press ENTER.

```
Special functions\Units of measurement\Barrel type
```

In this menu item it is possible to define which barrel type is to be displayed as unit of measurement for the volumetric flow rate.

- Select a barrel type.
- Press ENTER.

19.5 Material scroll list

At delivery, all stored materials are displayed in a scroll list in the menu item `Parameters\Pipe material`. For the sake of clarity, materials can be removed from the scroll list. Removed materials can be added at any time.

Addition or removal of a material

- Select the menu item `Special functions\Libraries\Use material list`.
- Press ENTER.

```
Special functions\Libraries\Use material list
```

- Select `Yes` if a material is to be added or removed from the material scroll list.
- Press ENTER.
- Press key `8` or `2` to scroll through the scroll list.
- Press key `6` or `4` to add (+) or remove (-) a material.
- Press ENTER.

Similarly, the fluid scroll list can be adapted (`Special functions\Libraries\Use fluid list`).

Addition of all materials

- Select the menu item `Special functions\Libraries\Use material list`.
- Press ENTER.

```
Special functions\Libraries\Use material list
```

- Select `No` if all materials are to be displayed in the material scroll list.
- Press ENTER.

Similarly, the fluid scroll list can be adapted (`Special functions\Libraries\Use fluid list`).

19.6 Working with parameter records

19.6.1 Introduction

Parameter records are data sets that contain all information necessary to perform a certain measurement task:

- pipe parameters
- transducer parameters
- fluid parameter
- output options

Working with parameter records will make repeated measurement tasks easier and faster. The transmitter can store max. 20 parameter records.

Notice!

No parameter records are stored in the delivery state. Parameter records are entered manually.

The parameters have first to be entered in the program branches `Parameters`, `Options` and `Special functions`. Afterwards, they can be stored as parameter record.

```
Special functions\Param. record memo.
```

- Select the menu item `Param. record memo.`
- Press ENTER.
- Select `Save current record.`
- Press ENTER.

```
Special functions\Param. record name
```

- Enter the name the parameter record has to be stored with.
- Press ENTER.

19.6.2 Load of a parameter record

Stored parameter records can be loaded and used for measurement.

```
Special functions\Param. record memo.\Load param. record
```

- Select the menu item `Load param. record.`
- Press ENTER.
- Select the parameter record to be loaded.
- Press ENTER.

19.6.3 Deletion of parameter records

```
Special functions\Param. record memo.\Delete param. record
```

- Select the menu item `Delete param. record.`
- Press ENTER.
- Select the parameter record to be deleted.
- Press ENTER.

19.7 Contrast settings

Special functions\System settings\Display contrast

- Select the menu item `System settings` in the program branch `Special functions`.
- Press ENTER.
- Select the menu item `Display contrast`.
- Press ENTER.

The display contrast is adjusted with the following keys:

 increases the contrast

 reduces the contrast

- Press ENTER.

Notice!

After an initialization of the transmitter, the display is reset to medium contrast.

19.8 HotCodes

A HotCode is a digit sequence that activates certain functions and settings.

- Press key  for several seconds to return to the beginning of the program branch.
- Press key C.
- Enter the HotCode via the keyboard. The HotCode is not displayed during the input.

function	HotCode
set display to medium contrast	555000
language	9090xx
initialization	909000
activate/deactivate flow direction detection	007026
activate/deactivate pig detection	007028
show totalization in lower display line as well	007032

Language

The language selection can either be carried out via the program branch `Special functions` or a HotCode:

language	HotCode
English	909044
German	909049
French	909033
Spanish	909034
Dutch	909031
Russian	909007
Polish	909048
Turkish	909090
Italian	909039

When the last digit has been entered, the main menu is displayed in the selected language. The selected language remains activated when the transmitter is switched off and on again.

19.9 Key lock

An ongoing measurement can be protected against unintentional intervention.

Definition of a key lock code

- Select the menu item `System settings` in the program branch `Special functions`.
- Press ENTER.

```
Special functions\System settings\Key lock
```

- Select `Key lock`.
- Press ENTER.
- Enter a 6-digit key lock code.
- Press ENTER.

Notice!

Do not forget the key lock code!

Intervention in the measurement

If the key lock is activated, the message `Key lock activated` will be displayed for a few seconds when pressing a key. In order to interrupt a measurement, the key lock has to be deactivated.

- Press key .
- Select `Show parameters`.
- Press ENTER.
- Deactivate the key lock.

Deactivation of the key lock

- Select the menu item `System settings` in the program branch `Special functions`.
- Press ENTER.

```
Special functions\System settings\Key lock
```

- Select `Key lock`.
- Press ENTER.
- Enter a 6-digit key lock code.
- Press ENTER.

Disabled functions with activated key lock

The following table gives an overview of the transmitter functions that are not available when the key lock is activated.

measurement not started	measurement started
<ul style="list-style-type: none"> • input of parameters • modification of settings (e.g., measuring modes) • deletion of the data logger • setting of time/date • start of measurement (start-up) 	<ul style="list-style-type: none"> • modification of settings that are available in an ongoing measurement (e.g., language selection) • triggering snaps • toggling to FastFood mode • toggling to NoiseTrek mode • stop of the totalizers • reset of the totalizers • stop of the measurement

Annex

A Menu structure

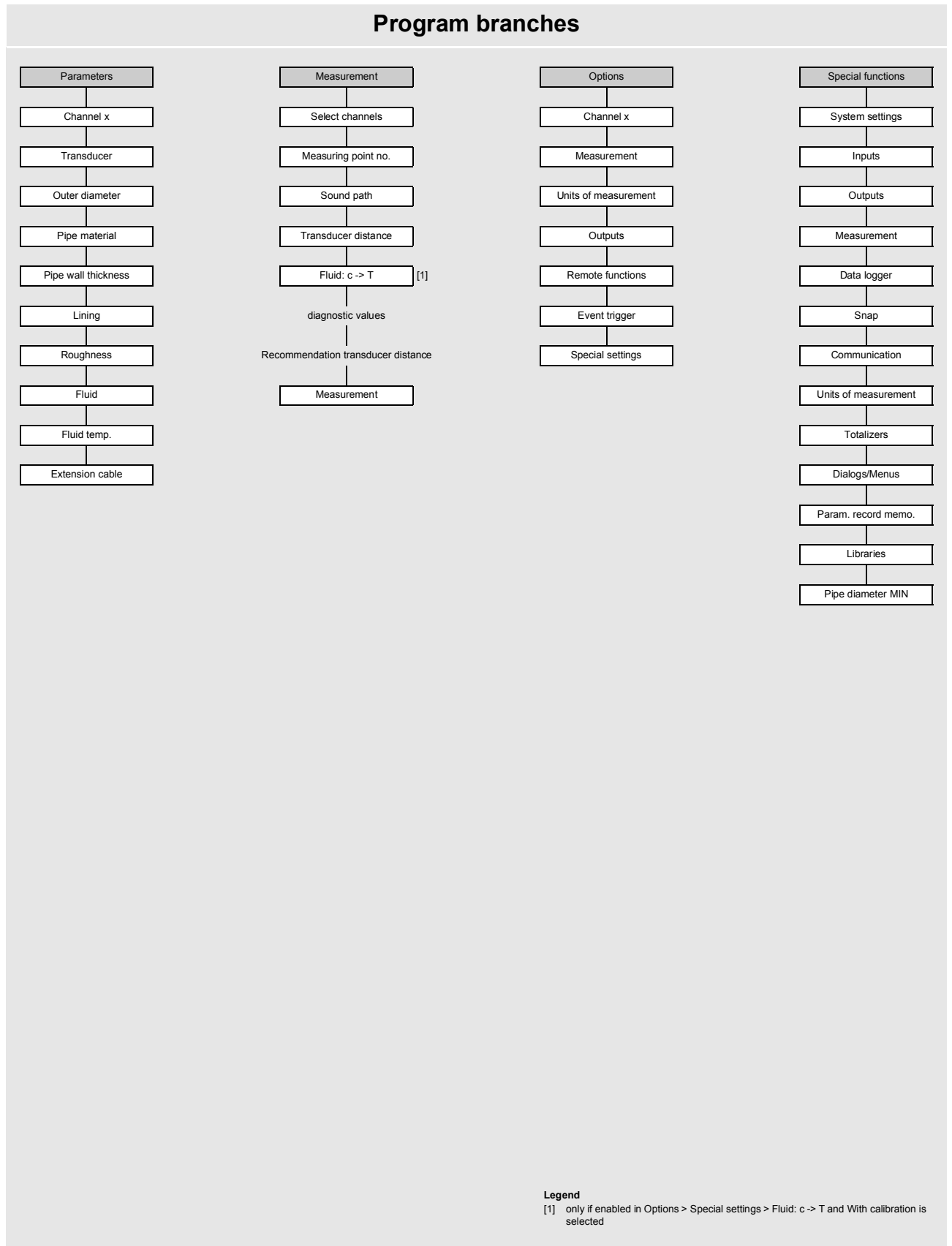

Parameter input

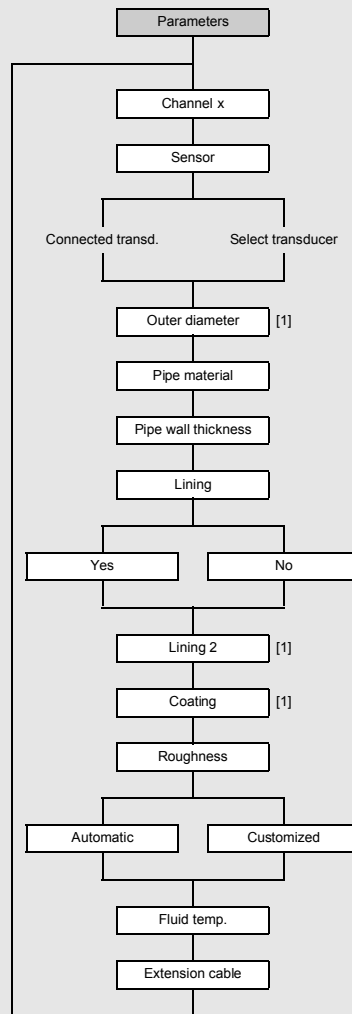

Legend
[1] only if enabled in Special functions > Dialogs/Menus

Measurement settings

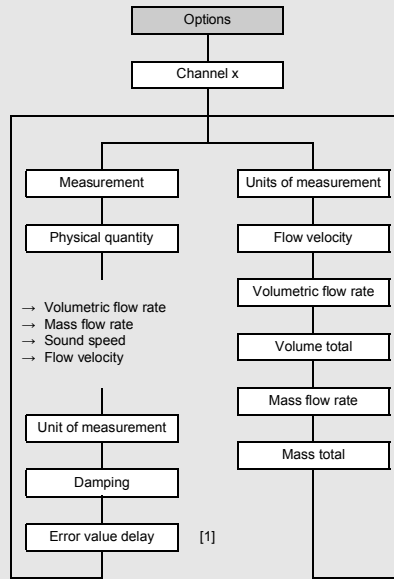

Legend

[1] only if enabled in Special functions > Dialogs/Menus

Data logger

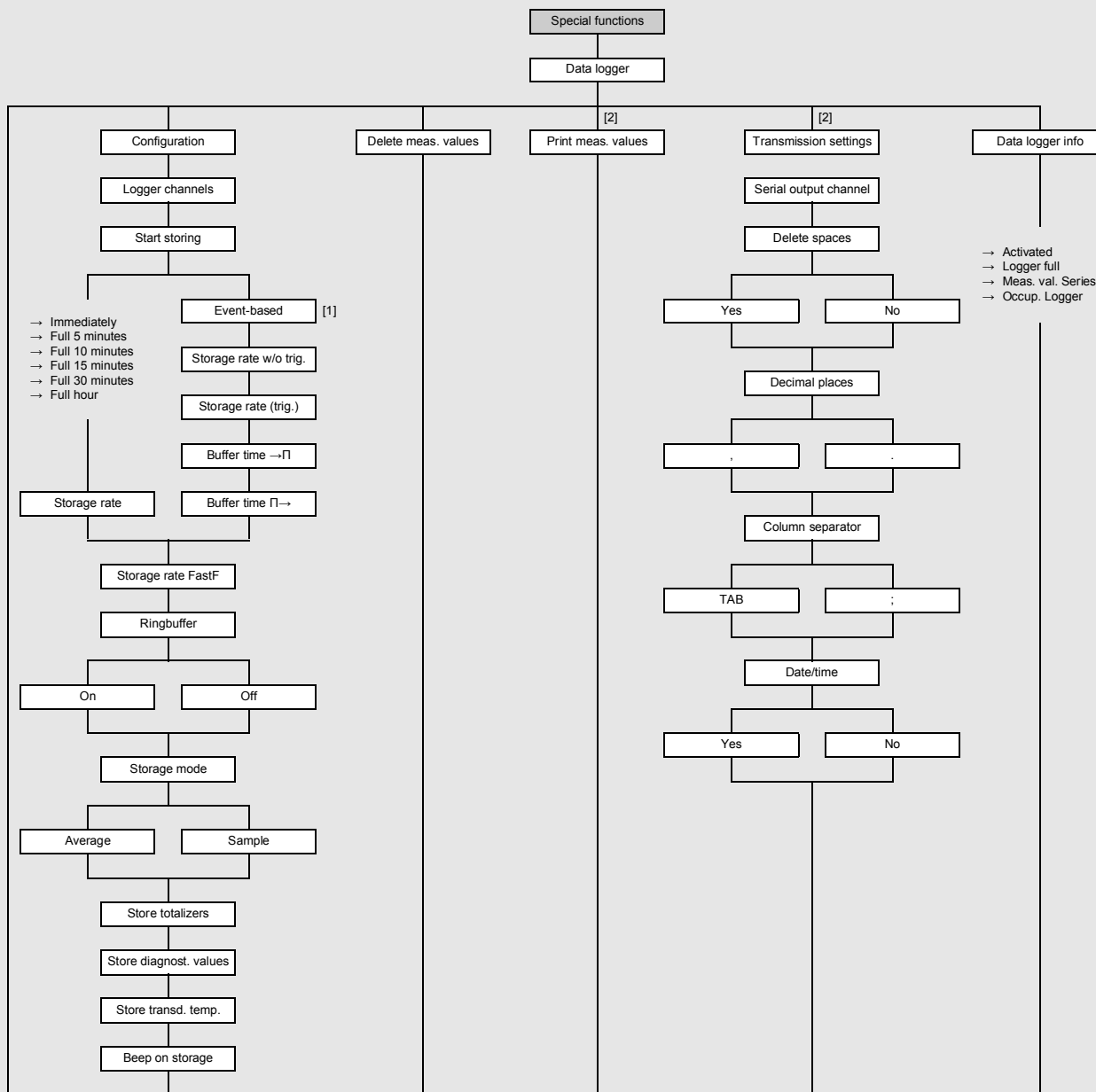

Legend
 [1] list of parameterized and triggerable inputs and event triggers
 [2] only if RS485 interface is available

Start of the measurement

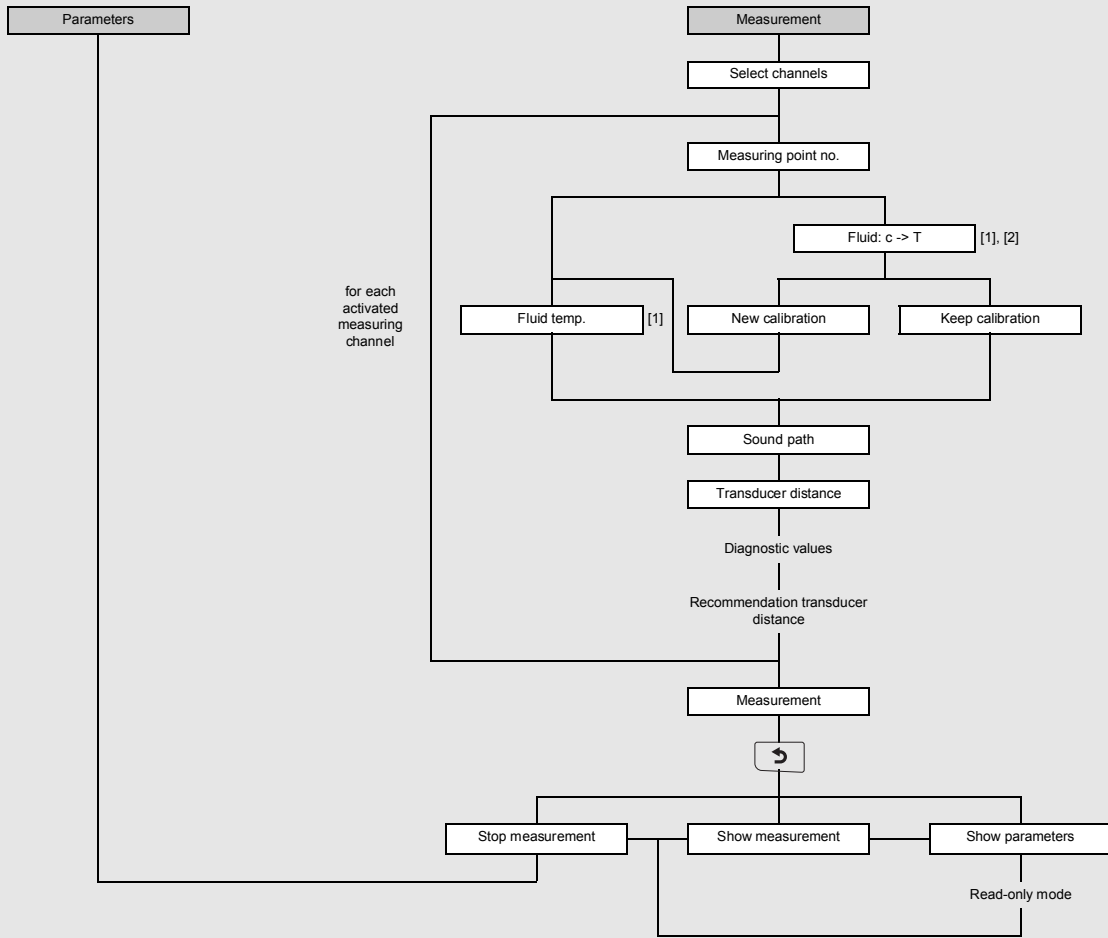

Legend

- [1] only if enabled in Options > Special settings > Fluid: c -> T and With calibration is selected
- [2] only if an offset has already been stored in the corresponding measuring channel of the transmitter

Configuration of outputs

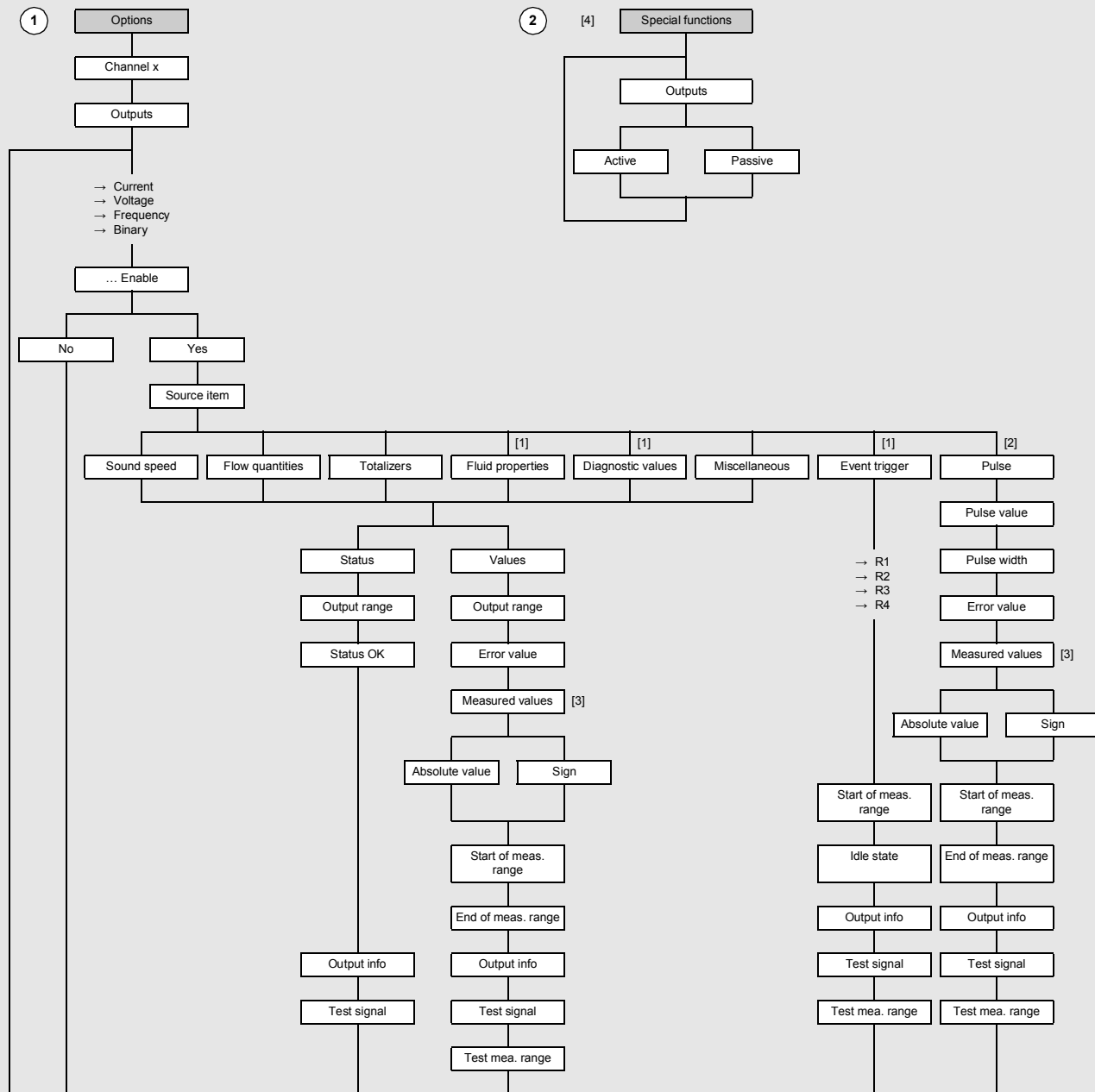

- Legend**
- [1] not available with calculation channels
 - [2] only available for binary outputs supporting pulse outputs
 - [3] request only if physical quantity can adopt a negative value
 - [4] only if switchable current outputs are available

Configuration of the inputs

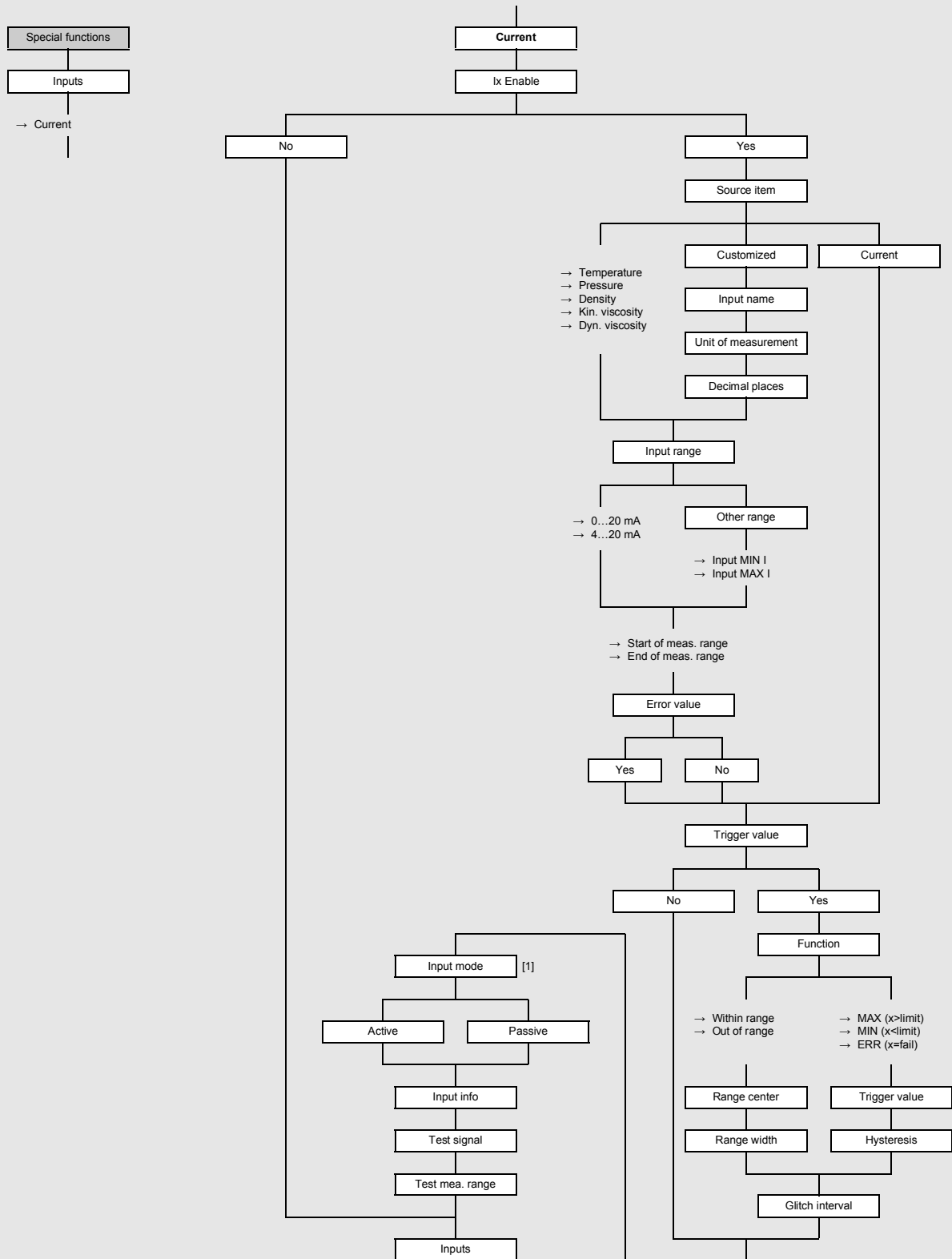

Legend
[1] only if supported by the hardware

Special settings

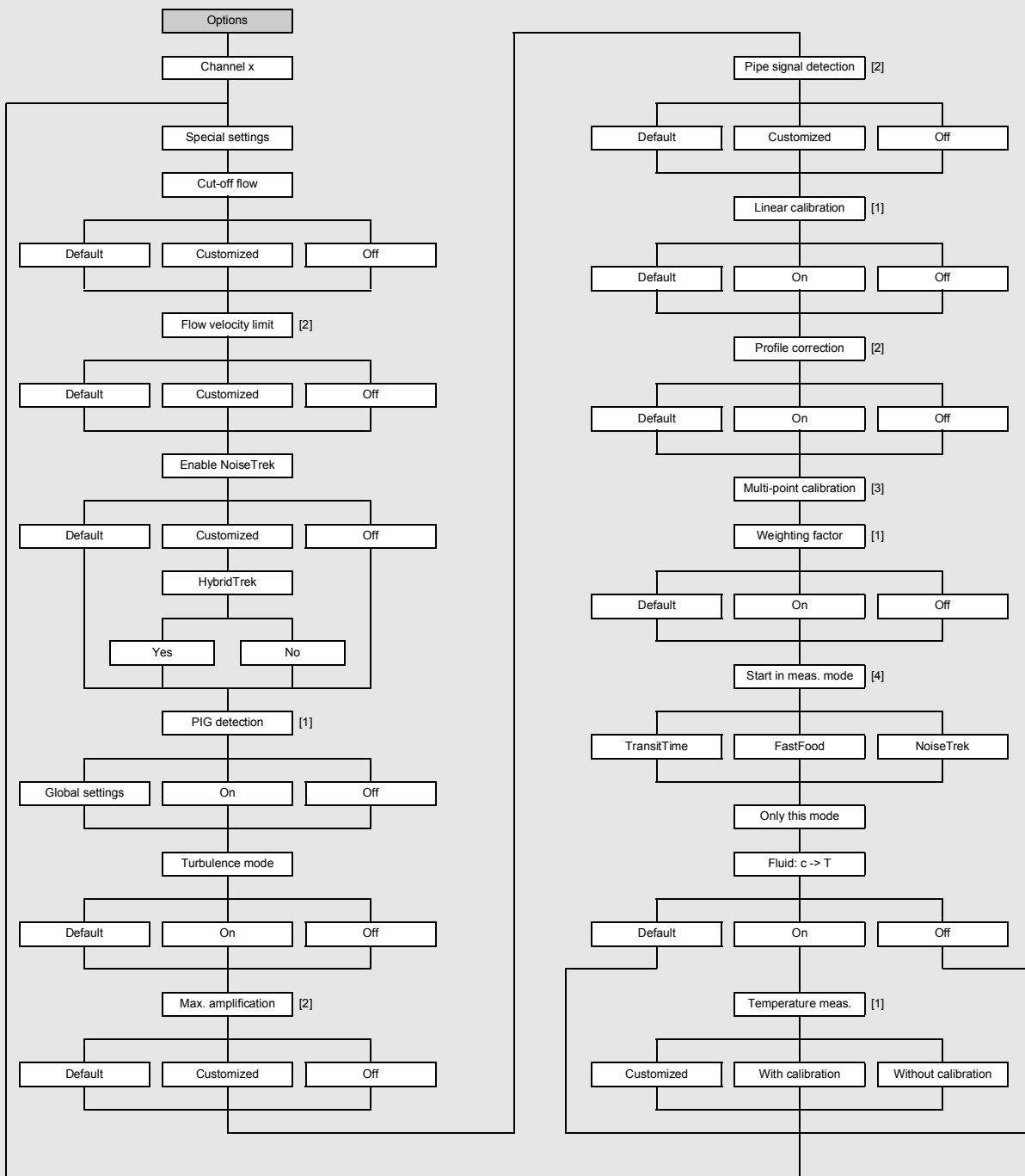

Legend

- [1] only in ExpertUser, SuperUser and SuperUser ext. mode
- [2] from ExpertUser mode
- [3] only if enabled in Special functions > Measurement > Measurement settings
- [4] only if FastFood is enabled in Special functions > Measurement > Measurement modes or NoiseTrek mode is supported

Calculation channels

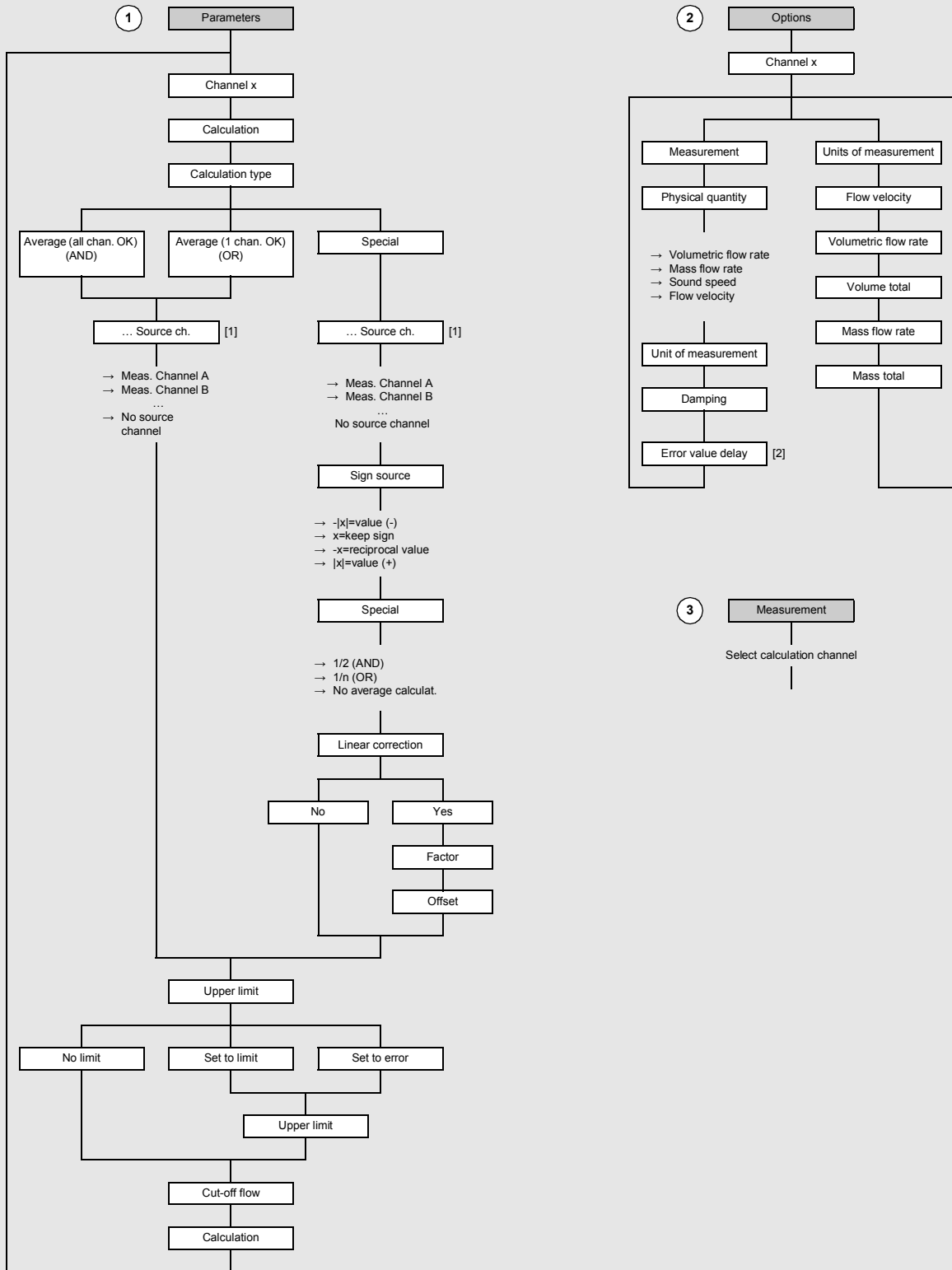

Legend

- [1] n corresponds to the number of physical channels in the transmitter
- [2] only if enabled in Special functions > Dialogs/Menus

Results – overview

Trigger

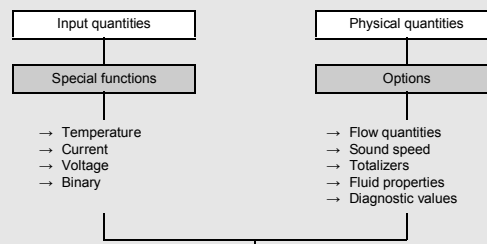

Condition

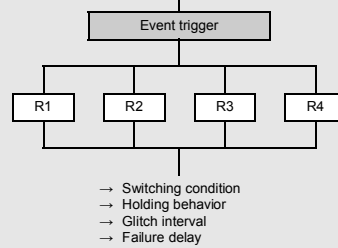

Action

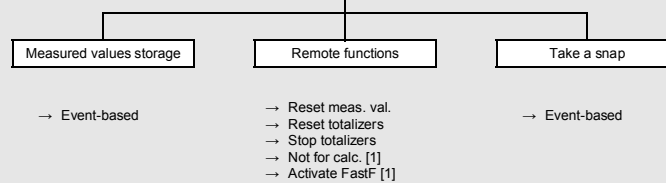

Legend
[1] only for physical channels

Definition of the event trigger

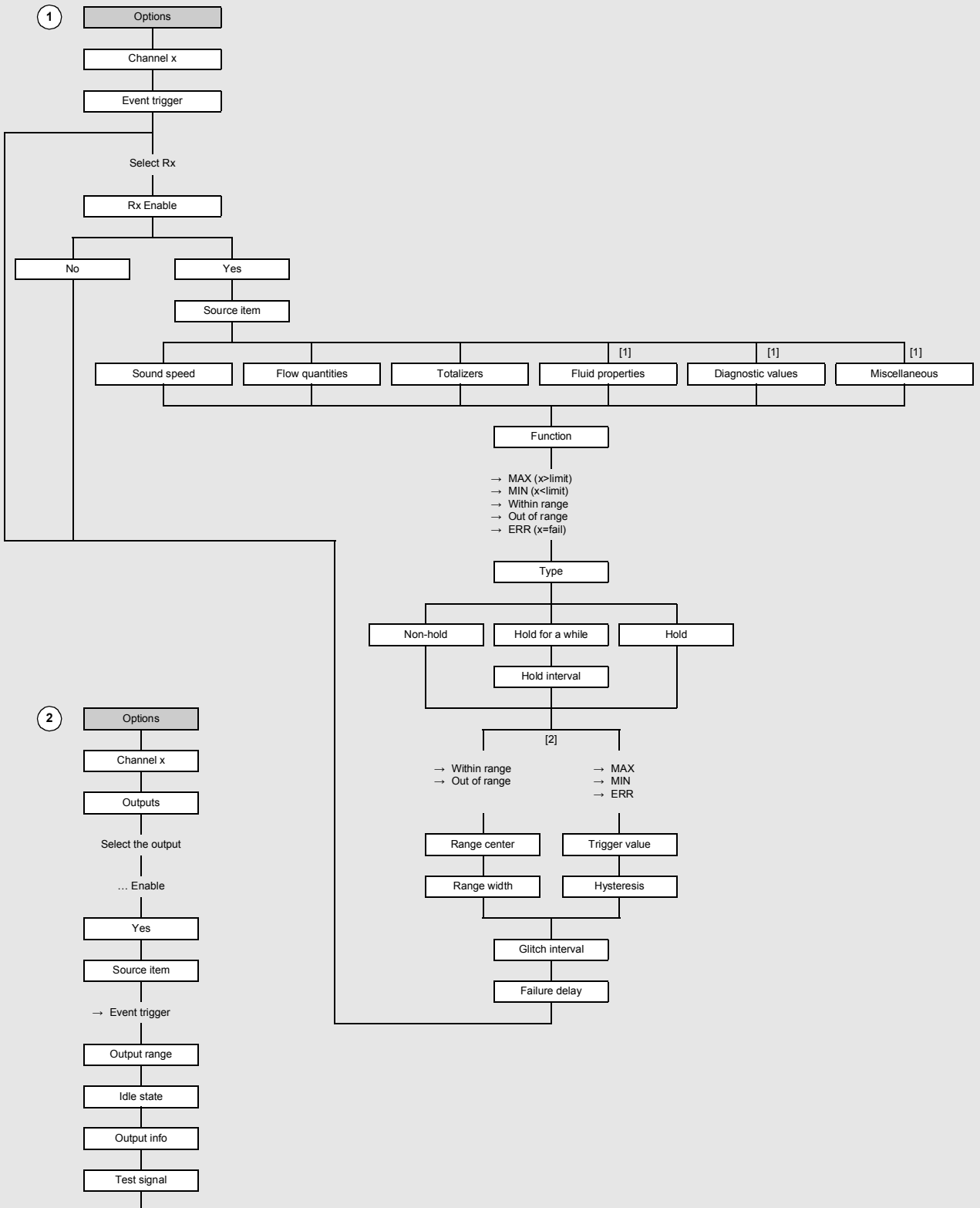

Legend

- [1] not available with calculation channels
- [2] depending on the selection of the function

Remote functions

1 Trigger

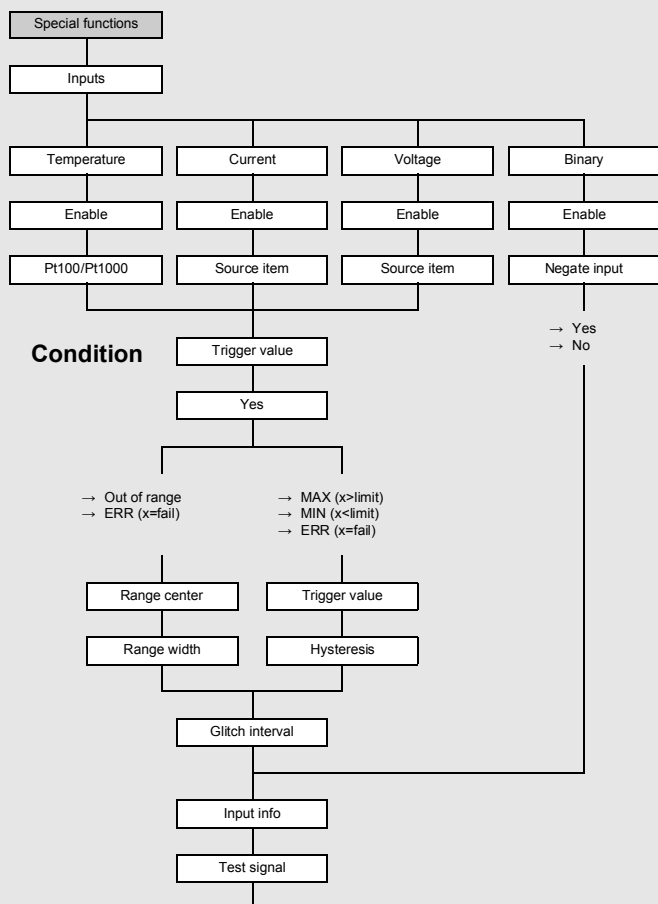

Condition

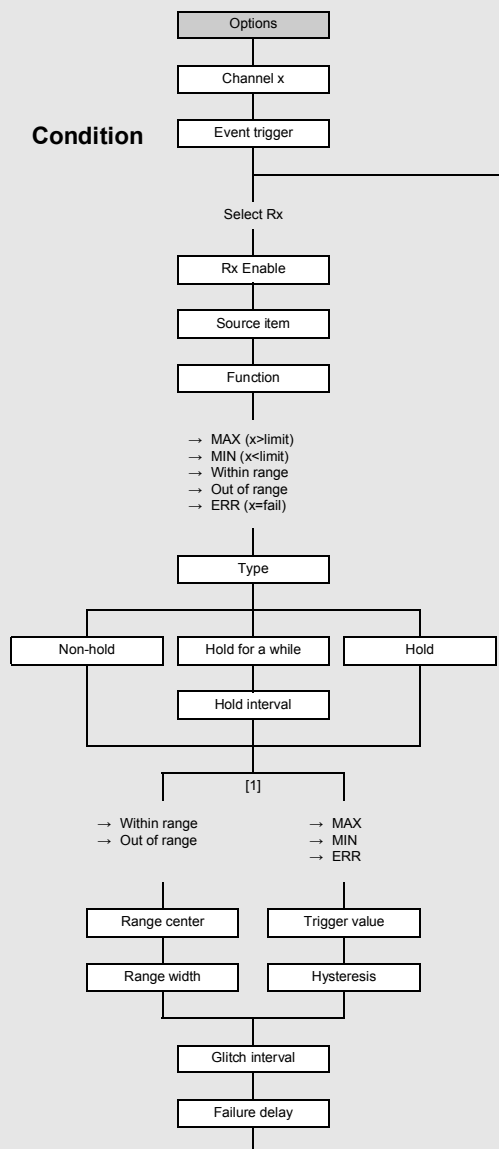

2 Action

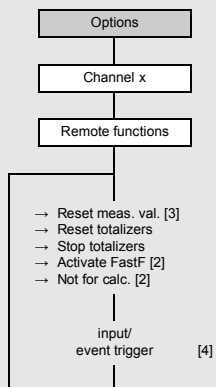

Legend

- [1] depending on the selection of the function
- [2] not available with calculation channels and only if FastFood mode is enabled in Special functions > Measurement > Measurement modes
- [3] only controllable via inputs
- [4] list of parameterized and triggerable inputs and event triggers

Event-based storing of measured values

1 Trigger

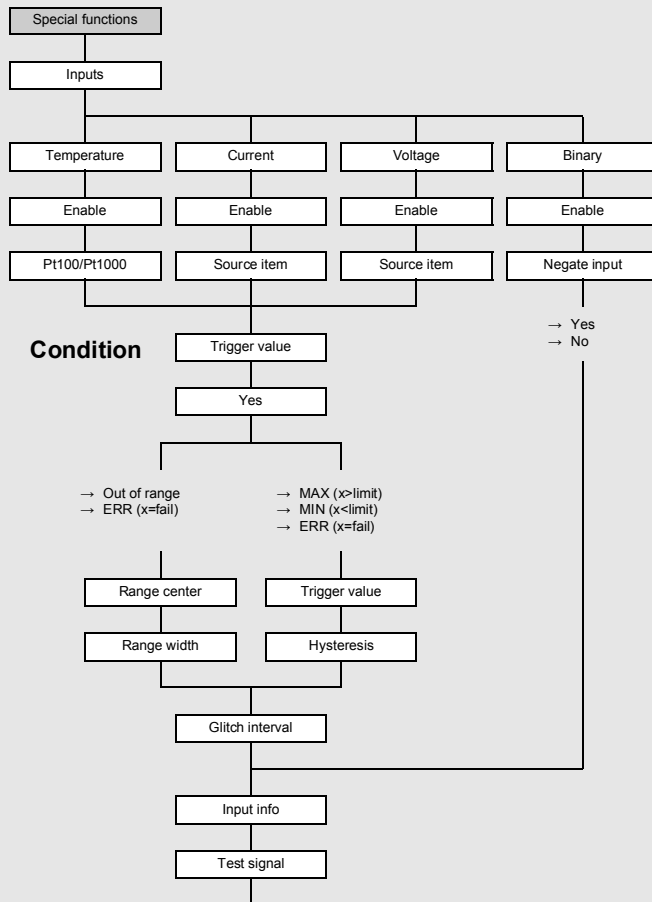

Condition

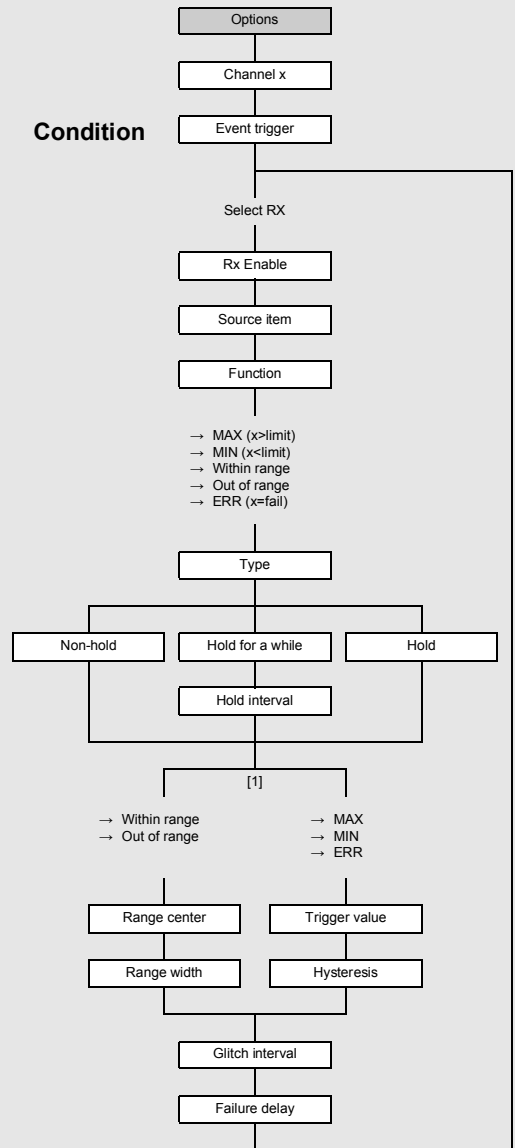

2 Action

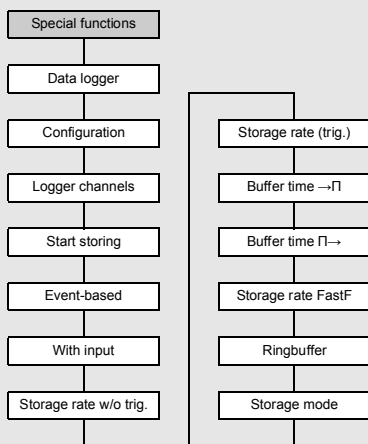

Legend

[1] depending on the selection of the function

Example 1

The diagnostic values are to be checked.

If the SCNR is < 20 dB, a snap has to be triggered.

Trigger: SCNR < 20 dB

Condition: R1 with SCNR < 20 dB

Action: trigger a snap

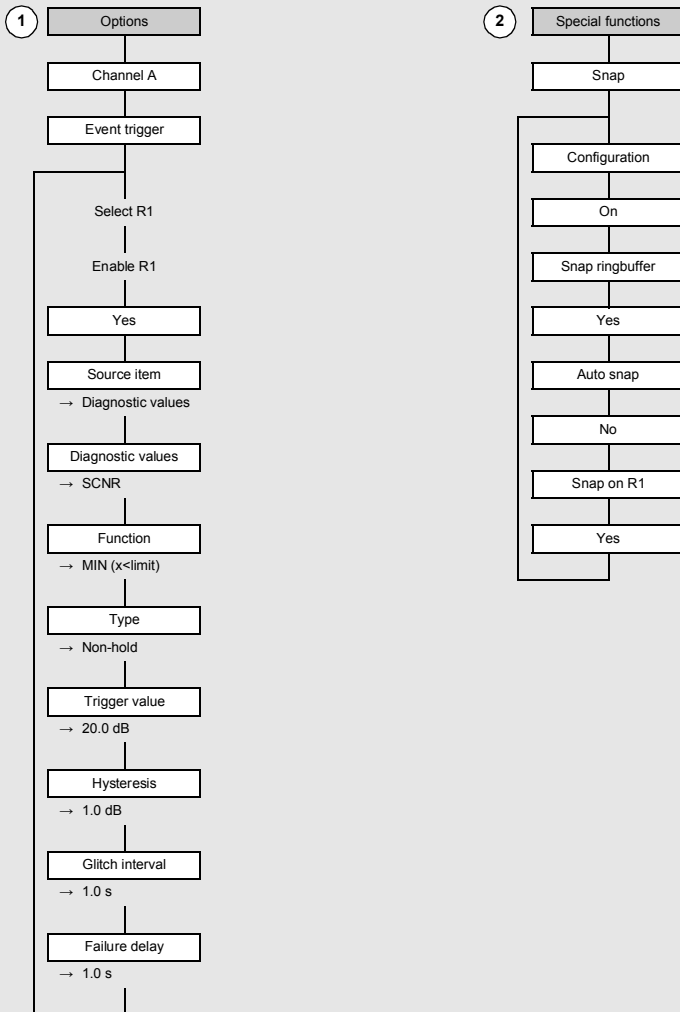

Example 2

The flow velocity is measured.

If the flow velocity is ≤ 5 m/s, the transmitter measures in the TransitTime mode. As long as the flow velocity is > 5 m/s, the transmitter has to measure in the FastFood mode.

Trigger: flow velocity > 5 m/s

Condition: R1 with flow velocity > 5 m/s

Action: measurement in the FastFood mode

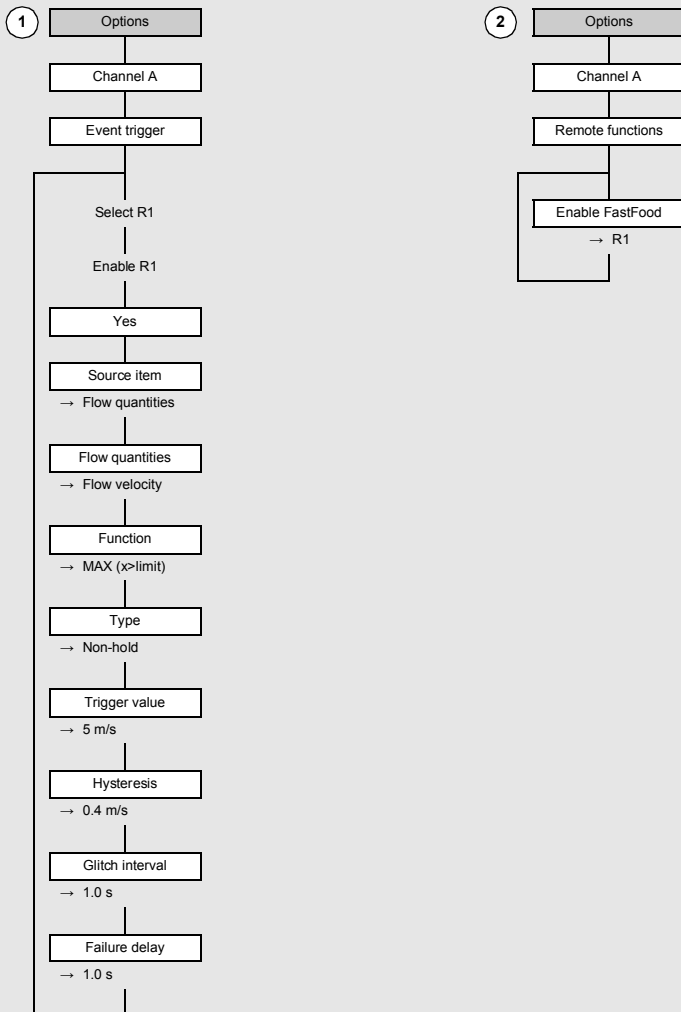

B Units of measurement

Length/roughness

unit of measurement	description
mm	millimeter
inch	inch

Temperature

unit of measurement	description
°C	degree Celsius
°F	degree Fahrenheit

Pressure

unit of measurement	description
bar(a)	bar (absolute)
bar(g)	bar (relative)
psi(a)	pound per square inch (absolute)
psi(g)	pound per square inch (relative)

Density

unit of measurement	description
g/cm ³	gram per cubic centimeter
kg/cm ³	kilogram per cubic centimeter

Sound speed

unit of measurement	description
m/s	meter per second

Kinematic viscosity

unit of measurement	description
mm ² /s	square millimeter per second

1 mm²/s = 1 cSt

Flow velocity

unit of measurement	description
m/s	meter per second
cm/s	centimeter per second
inch/s	inch per second
fps (ft/s)	foot per second

Volumetric flow rate

unit of measurement	description	volume (totalized) ⁽¹⁾
m ³ /d	cubic meter per day	m ³
m ³ /h	cubic meter per hour	m ³
m ³ /min	cubic meter per minute	m ³
m ³ /s	cubic meter per second	m ³
km ³ /h	cubic kilometer per hour	km ³
ml/min	milliliter per minute	l
l/h	liter per hour	l
l/min	liter per minute	l
l/s	liter per second	l
hl/h	hectoliter per hour	hl
hl/min	hectoliter per minute	hl
hl/s	hectoliter per second	hl
Ml/d (megaliter/d)	megaliter per day	Ml
bbl/d ⁽⁴⁾	barrel per day	bbl
bbl/h ⁽⁴⁾	barrel per hour	bbl
bbl/m ⁽⁴⁾	barrel per minute	bbl
bbl/s ⁽⁴⁾	barrel per second	bbl
USgpd (US-gal/d)	gallon per day	gal
USgph (US-gal/h)	gallon per hour	gal
USgpm (US-gal/m)	gallon per minute	gal
USgps (US-gal/s)	gallon per second	gal
KGPM (US-Kgal/m)	kilogallon per minute	kgal
MGD (US-Mgal/d)	million gallons per day	Mgal
CFD	cubic foot per day	cft ⁽²⁾
CFH	cubic foot per hour	cft
CFM	cubic foot per minute	cft
CFS	cubic foot per second	aft ⁽³⁾
MMCFD	million cubic feet per day	MMCF
MMCFH	million cubic feet per hour	MMCF

⁽¹⁾ selection in Options\Units of measurement

⁽²⁾ cft: cubic foot

⁽³⁾ aft: acre foot

⁽⁴⁾ In Special functions\Units of measurement\Barrel type it can be defined which barrel type is to be displayed for the settings of the units of measurement for the volumetric flow rate and the totalized volume.

1 US-gal = 3.78541 l

1 UK-gal = 4.54609 l

1 bbl = US Oil ≈ 159 l

1 bbl = US Wine ≈ 119 l

1 bbl = US Beer ≈ 117 l

1 bbl = UK ≈ 164 l

unit of measurement	description	volume (totalized) ⁽¹⁾
lgpd (Imp-gal/d)	gallon per day	lgal
lgph (Imp-gal/h)	gallon per hour	lgal
lgpm (Imp-gal/m)	gallon per minute	lgal
lgps (Imp-gal/s)	gallon per second	lgal
IKGM (Imp-Kgal/m)	imperial kilogallon per minute	IKG
IMGD (Imp-Mgal/d)	million imperial gallons per day	IMG

(1) selection in Options\Units of measurement

(2) cft: cubic foot

(3) aft: acre foot

(4) In Special functions\Units of measurement\Barrel type it can be defined which barrel type is to be displayed for the settings of the units of measurement for the volumetric flow rate and the totalized volume.

1 US-gal = 3.78541 l

1 UK-gal = 4.54609 l

1 bbl = US Oil ≈ 159 l

1 bbl = US Wine ≈ 119 l

1 bbl = US Beer ≈ 117 l

1 bbl = UK ≈ 164 l

Mass flow rate

unit of measurement	description	mass (totalized)
t/h	ton per hour	t
t/d	ton per day	t
kg/h	kilogram per hour	kg
kg/min	kilogram per minute	kg
kg/s	kilogram per second	kg
g/s	gram per second	g
lb/d	pound per day	lb
lb/h	pound per hour	lb
lb/m	pound per minute	lb
lb/s	pound per second	lb
klb/h	kilopound per hour	klb
klb/m	kilopound per minute	klb

1 lb = 453.59237 g

1 t = 1000 kg

C Reference

The following tables provide assistance for the user. The accuracy of the data depends on the composition, temperature and processing of the material. FLEXIM does not assume liability for any inaccuracies.

C.1 Sound speed of selected pipe and lining materials at 20 °C

The values of some of these materials are stored in the internal database of the transmitter. Column c_{flow} shows the sound speed (longitudinal or transversal) used for the flow measurement.

material (display)	explanation	c_{trans} [m/s]	c_{long} [m/s]	c_{flow}
Carbon Steel	steel, normal	3230	5930	trans
Stainless Steel	steel, stainless	3100	5790	trans
DUPLEX	duplex stainless steel	3272	5720	trans
Ductile Iron	ductile iron	2650	-	trans
Asbestos Cement	asbestos cement	2200	-	trans
Titanium	titanium	3067	5955	trans
Copper	copper	2260	4700	trans
Aluminium	aluminum	3100	6300	trans
Brass	brass	2100	4300	trans
Plastic	plastic	1120	2000	long
GRP	glass reinforced plastic (GRP)	-	2650	long
PVC	polyvinyl chloride	-	2395	long
PE	polyethylene	540	1950	long
PP	polypropylene	2600	2550	trans
Bitumen	bitumen	2500	-	trans
Acrylic	acrylic glass	1250	2730	long
Lead	lead	700	2200	long
Cu-Ni-Fe	copper-nickel-iron alloy	2510	4900	trans
Grey Cast Iron	gray cast iron	2200	4600	trans
Rubber	rubber	1900	2400	trans
Glass	glass	3400	5600	trans
PFA	perfluoralcoxy	500	1185	long
PVDF	polyvinylidene fluorid	760	2050	long
Sintimid	Sintimid	-	2472	long
Teka PEEK	Teka PEEK	-	2534	long
Tekason	Tekason	-	2230	long

The sound speed depends on the composition and the manufacturing process of the material. The sound speed of alloys and cast materials fluctuates strongly. The values only serve as an orientation.

C.2 Typical roughness values of pipes

The values are based on experience and measurements.

material	absolute roughness [mm]
drawn pipes of non-ferrous metal, glass, plastics and light metal	0...0.0015
drawn steel pipes	0.01...0.05
fine-planed, polished surface	max. 0.01
planed surface	0.01...0.04
rough-planed surface	0.05...0.1
welded steel pipes, new	0.05...0.1
after long use, cleaned	0.15...0.2
moderately rusted, slightly encrusted	max. 0.4
heavily encrusted	max. 3
cast iron pipes:	
bitumen lining	> 0.12
new, without lining	0.25...1
rusted	1...1.5
encrusted	1.5...3

C.3 Properties of water at 1 bar and at saturation pressure

fluid temperature [°C]	fluid pressure [bar]	sound speed [m/s]	density [kg/m ³]	specific heat capacity ¹ [kJ/kg/K ⁻¹]
0.1	1.013	1402.9	999.8	4.219
10	1.013	1447.3	999.7	4.195
20	1.013	1482.3	998.2	4.184
30	1.013	1509.2	995.6	4.180
40	1.013	1528.9	992.2	4.179
50	1.013	1542.6	988.0	4.181
60	1.013	1551.0	983.2	4.185
70	1.013	1554.7	977.8	4.190
80	1.013	1554.4	971.8	4.197
90	1.013	1550.5	965.3	4.205
100	1.013	1543.2	958.3	4.216
120	1.985	1519.9	943.1	4.244
140	3.615	1486.2	926.1	4.283
160	6.182	1443.2	907.4	4.335
180	10.03	1391.7	887.0	4.405
200	15.55	1332.1	864.7	4.496
220	23.20	1264.5	840.2	4.615
240	33.47	1189.0	813.4	4.772
260	46.92	1105.3	783.6	4.986
280	64.17	1012.6	750.3	5.289
300	85.88	909.40	712.1	5.750
320	112.8	793.16	667.1	6.537
340	146.0	658.27	610.7	8.208
360	186.7	479.74	527.6	15.00
373.946	220.640	72.356	322.0	∞

¹ at constant pressure

D Conformity declarations

We,

FLEXIM Flexible Industriemesstechnik GmbH
Boxberger Straße 4
12681 Berlin
Germany,



declare under our sole responsibility that the transmitters

FLUXUS *721 - NN0*A, FLUXUS *721** - NN0*S**

to which this declaration relates are in conformity with the following EU directives:

- EMC Directive 2014/30/EU for Electromagnetic Compatibility
- Low Voltage Directive 2014/35/EU for Electrical Safety
- Directive 2011/65/EU of the European Parliament and of the Council of 8 June 2011 on the restriction of the use of certain hazardous substances in electrical and electronic equipment
- Commission Delegated Directive (EU) 2015/863 of 31 March 2015 amending Annex II to Directive 2011/65/EU of the European Parliament and of the Council as regards the list of restricted substances

The transmitters are in conformity with the following European standards when used with the FLEXIM transducers and accessories:

EU directive	Class	Standard	Description
EMC Directive	- Immunity	EN 61326-1:2013	Electrical equipment for measurement, control and laboratory use – EMC requirements – General requirements
		EN 61326-1:2013	Electrical equipment for continuous, unattended operation intended to be used in an industrial electromagnetic environment
		EN 61000-4-2:2009	Electromagnetic compatibility (EMC) – Testing and measurement techniques – Electrostatic discharge immunity test
		EN 61000-4-3:2006 + A1:2008 + A2:2010	Electromagnetic compatibility (EMC) – Testing and measurement techniques – Radiated, radio-frequency, electromagnetic field immunity test
		EN 61000-4-4:2004 + A1:2010	Electromagnetic compatibility (EMC) – Testing and measurement techniques – Electrical fast transient/burst immunity test
		EN 61000-4-5:2006	Electromagnetic compatibility (EMC) – Testing and measurement techniques – Surge immunity test
		EN 61000-4-6:2009	Electromagnetic compatibility (EMC) – Testing and measurement techniques – Immunity to conducted disturbances, induced by radio-frequency fields
		EN 61000-4-11:2004	Electromagnetic compatibility (EMC) – Testing and measurement techniques – Voltage dips, short interruptions and voltage variations immunity tests
		- Emission	EN 61326-1:2013
	EN 55011:2009 + A1:2010		Industrial, scientific and medical equipment – Radio-frequency disturbance characteristics – Limits and methods of measurement

EU directive	Class	Standard	Description
Low Voltage Directive	Equipment Safety Requirement	EN 61010-1:2010	Safety requirements for electrical equipment for measurement, control, and laboratory use – General requirements
		EN 61010-2-030:2010	Safety requirements for electrical equipment for measurement, control, and laboratory use – Particular requirements for testing and measuring circuits
	- Insulation	EN 61010-1:2010	Pollution degree 2 Overvoltage category 2 Safety class 1

The installation, operating and safety instructions have to be observed!

Berlin, 2019-07-22



Dipl.-Ing. Jens Hilpert
Managing Director