



OPTISWIRL 4200 Handbook

Vortex flowmeter

Electronic revision: ER 2.0.1_

All rights reserved. It is prohibited to reproduce this documentation, or any part thereof, without the prior written authorisation of KROHNE Messtechnik GmbH.

Subject to change without notice.

Copyright 2017 by
KROHNE Messtechnik GmbH - Ludwig-Krohne-Str. 5 - 47058 Duisburg (Germany)

1	Safety instructions	6
1.1	Software history	6
1.2	Intended use	7
1.3	Certifications	9
1.4	Pressure equipment directive	10
1.5	Safety instructions from the manufacturer	11
1.5.1	Copyright and data protection	11
1.5.2	Disclaimer	11
1.5.3	Product liability and warranty	12
1.5.4	Information concerning the documentation	12
1.5.5	Warnings and symbols used	13
1.6	Safety instructions for the operator	13
2	Device description	14
2.1	Scope of delivery	14
2.2	Device versions	14
2.2.1	Devices with connection flange	15
2.2.2	Devices in sandwich version	15
2.2.3	Dual version and twofold reliability	16
2.2.4	Remote version	16
2.2.5	Devices with integrated nominal diameter reduction	17
2.2.6	Device description	17
2.2.7	Free air delivery measurement - FAD (optional)	18
2.2.8	Gross heat measurement (optional)	19
2.2.9	Net heat measurement (optional)	20
2.2.10	Dual seal	21
2.3	Nameplate	22
3	Installation	23
3.1	General notes on installation	23
3.2	Storage	23
3.3	Transport	23
3.4	Installation conditions	24
3.4.1	Prohibited installation when measuring liquids	25
3.4.2	Prohibited installation when measuring steam and gases	26
3.4.3	Pipelines with control valve	26
3.4.4	Preferred mounting position	27
3.5	Minimum inlet sections	28
3.6	Minimum outlet sections	29
3.7	Flow straightener	29
3.8	Installation	30
3.8.1	General installation notes	30
3.8.2	Installing devices in sandwich design	31
3.8.3	Installing devices in flange design	32
3.8.4	Mounting the field housing, remote version	33
3.9	Heat insulation	34
3.10	Turning the connection housing	35
3.11	Turning the display	36

4 Electrical connections	37
4.1 Safety instructions	37
4.2 Connecting the signal converter	38
4.3 Electrical connections	39
4.3.1 Power supply	39
4.3.2 Current output	39
4.3.3 Current input	40
4.3.4 Binary output	40
4.3.5 Limit switch output	41
4.3.6 Pulse output / Frequency output	43
4.3.7 Status output	44
4.4 Connection of remote version	44
4.5 Grounding connections	46
4.6 Ingress protection	47
5 Start-up	48
5.1 Start-up screen	48
5.2 Operation	48
6 Operation	49
6.1 Display and operating elements	49
6.1.1 Display for selection of submenu and functions, 3 lines	50
6.1.2 Display when setting parameters, 4 lines	51
6.1.3 Display when previewing parameters, 4 lines	51
6.2 Basic principles of operation	52
6.2.1 Functional description of the keys	52
6.2.2 Switch from measuring mode to menu mode	52
6.2.3 Change the settings in the menu	52
6.2.4 Character selection in change mode	53
6.2.5 Units, figures and factors	54
6.2.6 Security and permissions	54
6.3 Overview of the most important functions and units	56
6.4 Menu languages	56
6.5 Gas options for gas measurement	57
6.6 Units	58
6.7 Menu structure	61
6.7.1 Menu overview "A Quick Setup"	61
6.7.2 Menu overview "B Test"	62
6.7.3 Menu overview "C Setup"	63
6.7.4 Menu description "A Quick Setup"	67
6.7.5 Menu description "B Test"	75
6.7.6 Menu description "C Setup"	75
6.8 Setting examples	84
6.8.1 Settings for free air delivery measurement - FAD	84
6.8.2 Gross heat measurement	85
6.8.3 Net heat measurement	86
6.9 Status messages and diagnostic information	87
6.10 A12 plausibility checks	93

7 Service	94
7.1 Replacing signal converter / LC display	94
7.2 Maintaining the O-rings.....	95
7.3 Spare parts availability	96
7.4 Availability of services	96
7.5 Returning the device to the manufacturer.....	96
7.5.1 General information.....	96
7.5.2 Form (for copying) to accompany a returned device.....	97
7.6 Disposal	97
8 Technical data	98
8.1 Functional principle.....	98
8.2 Technical data.....	99
8.3 Dimensions and weights	104
8.3.1 Flange versions.....	104
8.3.2 Sandwich version	111
8.3.3 Dimensions of remote version.....	113
8.4 Flow tables	114
9 Notes	117

1.1 Software history

The "Electronic Revision" (ER) is consulted to document the revision status of electronic equipment according to NE 53 for all devices. It is easy to see from the ER whether troubleshooting or larger changes in the electronic equipment have taken place and how that has affected the compatibility.

Changes and effect on compatibility

1	Downwards compatible changes and fault repair with no effect on operation (e.g. spelling mistakes on display)	
2- _	Downwards compatible hardware and/or software change of interfaces:	
	H	HART®
	P	Profibus
	F	Foundation Fieldbus
3- _	Downwards compatible hardware and/or software change of inputs and outputs:	
	CO	Current output
	FO, PO	Frequency output / pulse output
	SO	Status output
	LS	Limit switch
	CI	Current input
	D	Display
4	Downwards compatible changes with new functions	
5	Incompatible changes, i.e. electronic equipment must be changed	

Release date	Electronic revision	Changes and compatibility	Documentation
2014-12-10	ER 1.0.0_	-	MA OPTISWIRL 4200 R01
2015-01-07	ER 1.0.1_	1; 2-H	MA OPTISWIRL 4200 R01
2015-02-04	ER 1.0.2_	1; 3-PO	MA OPTISWIRL 4200 R01
2015-03-04	ER 1.0.3_	1; 2-H; 3-CO; 3-PO; 3-CI; 3-D	MA OPTISWIRL 4200 R01
2015-09-07	ER 1.0.4_	1; 2-H; 3-D	MA OPTISWIRL 4200 R01
2016-04-18	ER 1.0.5_	1; 3-PO; 3-SO	MA OPTISWIRL 4200 R02
2016-08-19	ER 1.0.6_	1; 3-D	MA OPTISWIRL 4200 R03
2017-07-10	ER 2.0.0_	5	MA OPTISWIRL 4200 R04
2017-10-01	ER 2.0.1_	1	MA OPTISWIRL 4200 R05

1.2 Intended use

**CAUTION!**

Responsibility for the use of the measuring devices with regard to suitability, intended use and corrosion resistance of the used materials against the measured fluid lies solely with the operator.

**INFORMATION!**

This device is a Group 1, Class A device as specified within CISPR11:2009. It is intended for use in industrial environment. There may be potential difficulties in ensuring electromagnetic compatibility in other environments, due to conducted as well as radiated disturbances.

**INFORMATION!**

The manufacturer is not liable for any damage resulting from improper use or use for other than the intended purpose.

The vortex flowmeters are used for flow measurement of gases, vapours and liquids.

The devices are particularly suitable for the measurement of:

- Clean liquids with low viscosity (< 10 cP)
- Hydrocarbons with low viscosity (< 10 cP)
- Water
- Chemicals with low corrosiveness
- Saturated steam
- Superheated steam, including CIP and SIP applications in the food industry

- The flow sensors are made from stainless steel 1.4404 / 316L or Hastelloy® C-22.
- In your project planning, please observe the data given in the corrosion tables.
- The pressure-bearing parts have been designed and rated for stationary operation taking into account the maximum pressure and temperature.
- Observe the data indicated on the nameplate for PS, TS and PT.
- External forces and moments, caused e.g. by pipe stresses, have not been taken into account.

Primarily, volumetric flow and temperature are measured, with pressure measurement as an option. From these parameters the measuring device calculates the mass flow or standard volumetric flow using pre-programmed density data and then exports the measured values via various communication interfaces.

The devices are rated for the following flow velocities:

Liquids: DN15...DN300		V_{\min} : 0.3 m/s ③	0.98 ft/s	$V_{\min} [\text{m/s}] = 0.5 \times \sqrt{\frac{998}{\rho}} \quad \rho \left[\frac{\text{kg}}{\text{m}^3} \right]$	①
		V_{\max} : 10 m/s	32 ft/s	$V_{\max} [\text{m/s}] = 7 \times \left(\frac{998}{\rho} \right)^{0.47} \quad \rho \left[\frac{\text{kg}}{\text{m}^3} \right]$	②
Gases and steam:	DN15	V_{\min} : 3 m/s	10 ft/s	$V_{\min} [\text{m/s}] = 6 \times \sqrt{\frac{1.204}{\rho}} \quad \rho \left[\frac{\text{kg}}{\text{m}^3} \right]$	①
		V_{\max} : 45 m/s	147 ft/s	$V_{\max} [\text{m/s}] = 7 \times \left(\frac{998}{\rho} \right)^{0.47} \quad \rho \left[\frac{\text{kg}}{\text{m}^3} \right]$	②
	DN15C	V_{\min} : 3 m/s	10 ft/s	$V_{\min} [\text{m/s}] = 12 \times \sqrt{\frac{1.204}{\rho}} \quad \rho \left[\frac{\text{kg}}{\text{m}^3} \right]$	①
		V_{\max} : 55 m/s	180 ft/s	$V_{\max} [\text{m/s}] = 7 \times \left(\frac{998}{\rho} \right)^{0.47} \quad \rho \left[\frac{\text{kg}}{\text{m}^3} \right]$	②
	DN25	V_{\min} : 2 m/s	6.6 ft/s	$V_{\min} [\text{m/s}] = 6 \times \sqrt{\frac{1.204}{\rho}} \quad \rho \left[\frac{\text{kg}}{\text{m}^3} \right]$	①
		V_{\max} : 70 m/s	229 ft/s	$V_{\max} [\text{m/s}] = 7 \times \left(\frac{998}{\rho} \right)^{0.47} \quad \rho \left[\frac{\text{kg}}{\text{m}^3} \right]$	②
	DN25C	V_{\min} : 2 m/s	6.6 ft/s	$V_{\min} [\text{m/s}] = 12 \times \sqrt{\frac{1.204}{\rho}} \quad \rho \left[\frac{\text{kg}}{\text{m}^3} \right]$	①
		V_{\max} : 80 m/s	262 ft/s	$V_{\max} [\text{m/s}] = 7 \times \left(\frac{998}{\rho} \right)^{0.47} \quad \rho \left[\frac{\text{kg}}{\text{m}^3} \right]$	②
	DN40... DN300	V_{\min} : 2 m/s	6.6 ft/s	$V_{\min} [\text{m/s}] = 6 \times \sqrt{\frac{1.204}{\rho}} \quad \rho \left[\frac{\text{kg}}{\text{m}^3} \right]$	①
		V_{\max} : 80 m/s	262 ft/s	$V_{\max} [\text{m/s}] = 7 \times \left(\frac{998}{\rho} \right)^{0.47} \quad \rho \left[\frac{\text{kg}}{\text{m}^3} \right]$	②

① Use the larger value, according to the amount.

② Use the smaller value, according to the amount.

③ $v_{\min} = 0.7 \text{ m/s} / 2.3 \text{ ft/s}$ in SIL mode for liquid application.



INFORMATION!

DN15C and DN25C have a robust flow sensor (signal pick-up) for harsh measuring conditions and higher maximum velocity compared to the standard version.

1.3 Certifications

CE marking



The device fulfils the statutory requirements of the following EU directives:

- Pressure equipment directive
- EMC directive
- Devices for use in hazardous areas: ATEX directive

as well as

- EN 61010
- NAMUR recommendations NE 21 and NE 43

The manufacturer certifies successful testing of the product by applying the CE marking. An EU declaration of conformity regarding the directives in question and the associated harmonised standards can be downloaded from our internet site.



DANGER!

For devices used in hazardous areas, additional safety notes apply; please refer to the Ex documentation.



CAUTION!

*For devices used in SIL applications, additional safety notes apply.
For detailed information refer to the "Safety Manual".*

1.4 Pressure equipment directive

A conformity assessment in accordance with pressure equipment directive has been carried out for the devices described. Conformity is certified by applying the CE mark. The number of the notified body is also stated.

The PED key describes the rating of the devices:

Example: PED/G1/III/H

G	Gases and vapours
1	Fluid group 1
III	Category III
H	Conformity assessment method according to Module H

The PED key identification can be found on the nameplate of the device (for details refer to *Nameplate* on page 22).



INFORMATION!

The stated pressures (PS) and temperatures (TS) only apply as refers to the pressure resistance of the sensor body. As regards the functionality of the entire device, further restrictions of the maximum temperature may need to be observed (e.g. ATEX approval). Devices rated below category I due to their size, do not receive the CE mark in the scope of the PED. These devices are subject to applicable sound engineering practice (SEP).

Residual risk

A risk analysis in accordance with the pressure equipment directive has been carried out for the devices. The residual risk is described as follows:

- The devices are designed according to the valid and applicable rules and standards for static operation and their pressure resistance is calculated for the declared maximum pressure and temperature (no calculation for cyclical change).
- Responsibility for the use of the measuring devices with regard to corrosion resistance of the used materials against the measured fluid lies solely with the operator.
- Don't use abrasive and high viscous media.
- Avoid pulsation and cavitation.
- The maximum allowable ambient temperatures are depending on the device equipment and declared in the technical data.
- The draining of the device will be performed in the same way as the connected pipeline.
- Protect devices from vibration and high-frequency oscillation.
- Implement appropriate measures to counteract external fire hazards

1.5 Safety instructions from the manufacturer

1.5.1 Copyright and data protection

The contents of this document have been created with great care. Nevertheless, we provide no guarantee that the contents are correct, complete or up-to-date.

The contents and works in this document are subject to copyright. Contributions from third parties are identified as such. Reproduction, processing, dissemination and any type of use beyond what is permitted under copyright requires written authorisation from the respective author and/or the manufacturer.

The manufacturer tries always to observe the copyrights of others, and to draw on works created in-house or works in the public domain.

The collection of personal data (such as names, street addresses or e-mail addresses) in the manufacturer's documents is always on a voluntary basis whenever possible. Whenever feasible, it is always possible to make use of the offerings and services without providing any personal data.

We draw your attention to the fact that data transmission over the Internet (e.g. when communicating by e-mail) may involve gaps in security. It is not possible to protect such data completely against access by third parties.

We hereby expressly prohibit the use of the contact data published as part of our duty to publish an imprint for the purpose of sending us any advertising or informational materials that we have not expressly requested.

1.5.2 Disclaimer

The manufacturer will not be liable for any damage of any kind by using its product, including, but not limited to direct, indirect or incidental and consequential damages.

This disclaimer does not apply in case the manufacturer has acted on purpose or with gross negligence. In the event any applicable law does not allow such limitations on implied warranties or the exclusion of limitation of certain damages, you may, if such law applies to you, not be subject to some or all of the above disclaimer, exclusions or limitations.

Any product purchased from the manufacturer is warranted in accordance with the relevant product documentation and our Terms and Conditions of Sale.

The manufacturer reserves the right to alter the content of its documents, including this disclaimer in any way, at any time, for any reason, without prior notification, and will not be liable in any way for possible consequences of such changes.

1.5.3 Product liability and warranty

The operator shall bear responsibility for the suitability of the device for the specific purpose. The manufacturer accepts no liability for the consequences of misuse by the operator. Improper installation or operation of the devices (systems) will cause the warranty to be void. The respective "Standard Terms and Conditions" which form the basis for the sales contract shall also apply.

1.5.4 Information concerning the documentation

To prevent any injury to the user or damage to the device it is essential that you read the information in this document and observe applicable national standards, safety requirements and accident prevention regulations.

If this document is not in your native language and if you have any problems understanding the text, we advise you to contact your local office for assistance. The manufacturer can not accept responsibility for any damage or injury caused by misunderstanding of the information in this document.

This document is provided to help you establish operating conditions, which will permit safe and efficient use of this device. Special considerations and precautions are also described in the document, which appear in the form of icons as shown below.

1.5.5 Warnings and symbols used

Safety warnings are indicated by the following symbols.



DANGER!

This warning refers to the immediate danger when working with electricity.



DANGER!

This warning refers to the immediate danger of burns caused by heat or hot surfaces.



DANGER!

This warning refers to the immediate danger when using this device in a hazardous atmosphere.



DANGER!

These warnings must be observed without fail. Even partial disregard of this warning can lead to serious health problems and even death. There is also the risk of seriously damaging the device or parts of the operator's plant.



WARNING!

Disregarding this safety warning, even if only in part, poses the risk of serious health problems. There is also the risk of damaging the device or parts of the operator's plant.



CAUTION!

Disregarding these instructions can result in damage to the device or to parts of the operator's plant.



INFORMATION!

These instructions contain important information for the handling of the device.



LEGAL NOTICE!

This note contains information on statutory directives and standards.



• **HANDLING**

This symbol designates all instructions for actions to be carried out by the operator in the specified sequence.

➔ **RESULT**

This symbol refers to all important consequences of the previous actions.

1.6 Safety instructions for the operator



WARNING!

*In general, devices from the manufacturer may only be installed, commissioned, operated and maintained by properly trained and authorized personnel.
This document is provided to help you establish operating conditions, which will permit safe and efficient use of this device.*

2.1 Scope of delivery



INFORMATION!

Inspect the packaging carefully for damages or signs of rough handling. Report damage to the carrier and to the local office of the manufacturer.



INFORMATION!

Do a check of the packing list to make sure that you have all the elements given in the order.



INFORMATION!

Look at the device nameplate to ensure that the device is delivered according to your order. Check for the correct supply voltage printed on the nameplate.

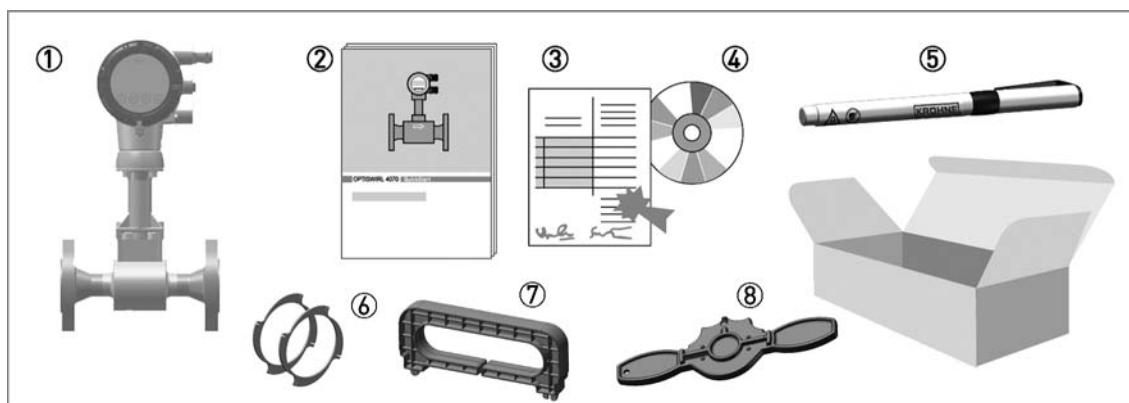

Figure 2-1: Scope of delivery

- ① Measuring device in ordered version
- ② Product documentation
- ③ Certificates, calibration report and parameter data sheet
- ④ CD with complete documentation
- ⑤ Bar magnet
- ⑥ Centering rings (only for sandwich devices)
- ⑦ Handle to pull off the display
- ⑧ Key for opening the front and rear cover

2.2 Device versions

The devices are delivered in the following variants:

- Signal converter with display
- Flow sensor in flanged design, flow sensor F
- Flow sensor in sandwich design, flow sensor S
- Remote version - Flow sensor with separated remote signal converter
- Dual version with two flow sensors and two signal converters

The following designs are available as options:

- With pressure sensor - with or without shut-off valve
- Flange version, flow sensor with single reduction F1R
- Flange version, flow sensor with double reduction F2R

2.2.1 Devices with connection flange

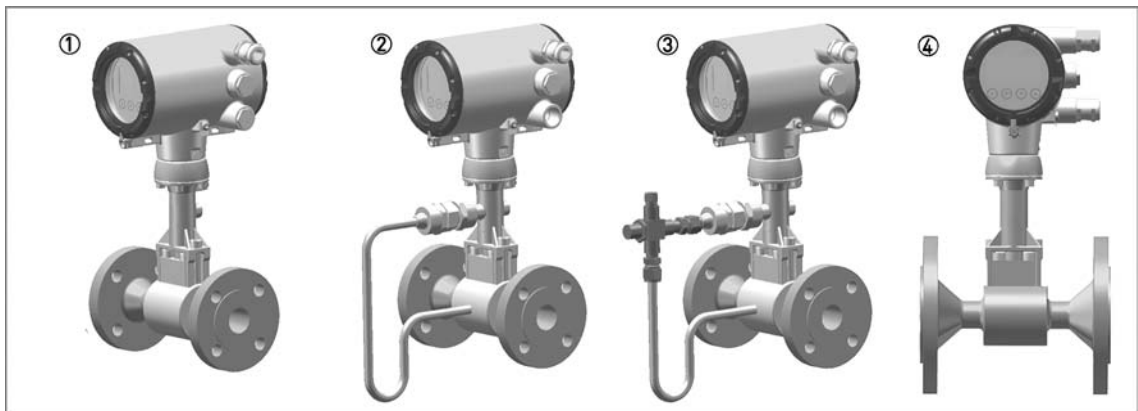

Figure 2-2: Flanged devices with display

- ① Version with temperature sensor
- ② Version with temperature sensor and optional pressure sensor
- ③ Version with temperature sensor, optional pressure sensor and shut-off valve
- ④ Version with temperature sensor, flow sensor with integrated reducer

2.2.2 Devices in sandwich version

The sandwich version features 2 centering rings to aid with installation.

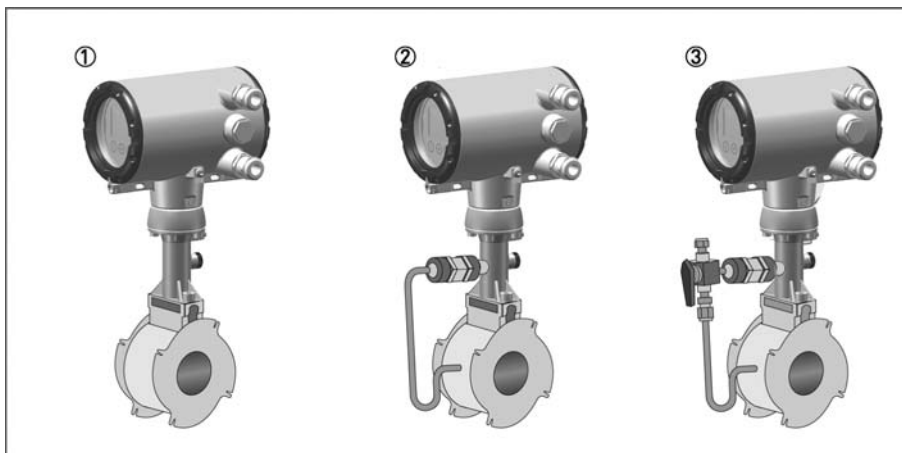

Figure 2-3: Sandwich versions with display

- ① Version with temperature sensor
- ② Version with temperature sensor and optional pressure sensor
- ③ Version with temperature sensor, optional pressure sensor and shut-off valve

2.2.3 Dual version and twofold reliability



This is a genuine redundant system with two independent flow sensors and two signal converters.

This provides twofold functional reliability and availability of the measurement. This variant is ideally suited for measurements in multi-product pipelines. In such pipelines, two different products are moved through one after the other. One signal converter can be programmed for one product, and the other signal converter for the other product.

2.2.4 Remote version

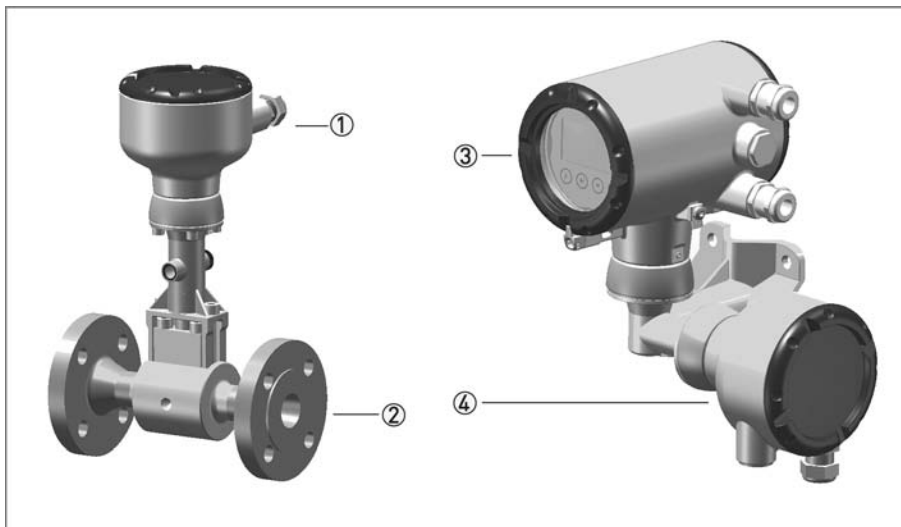

Figure 2-4: Remote version

- ① Flow sensor connection box
- ② Flow sensor
- ③ Signal converter
- ④ Wall mount bracket connection box

With the remote version, the flow sensor and signal converter are installed separately in different places. The 6-pin, shielded connection cable is available with a length up to 50 m / 164 ft.

2.2.5 Devices with integrated nominal diameter reduction

The device versions F1R and F2R offer an integrated nominal diameter reduction up to two nominal diameter sizes to assure best results in accuracy and optimum measuring ranges; even in pipelines with large diameters, which have been designed for a low pressure loss.

Nominal diameter of flow sensor	Nominal size of process connections									
	DN15	DN25	DN40	DN50	DN80	DN100	DN150	DN200	DN250	DN300
DN15	StV ①	F1R	F2R	-	-	-	-	-	-	-
DN25	-	StV ①	F1R	F2R	-	-	-	-	-	-
DN40	-	-	StV ①	F1R	F2R	-	-	-	-	-
DN50	-	-	-	StV ①	F1R	F2R	-	-	-	-
DN80	-	-	-	-	StV ①	F1R	F2R	-	-	-
DN100	-	-	-	-	-	StV ①	F1R	F2R	-	-
DN150	-	-	-	-	-	-	StV ①	F1R	F2R	-
DN200	-	-	-	-	-	-	-	StV ①	F1R	F2R
DN250	-	-	-	-	-	-	-	-	StV ①	F1R
DN300	-	-	-	-	-	-	-	-	-	StV ①

① Standard version

2.2.6 Device description

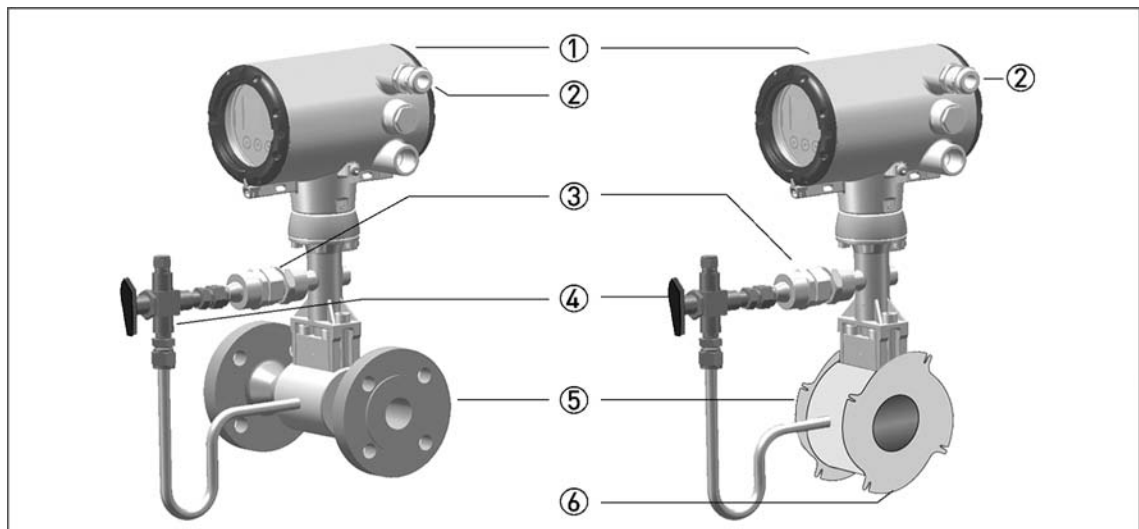

Figure 2-5: Device description

- ① Signal converter
- ② Cable feed through
- ③ Pressure sensor, optional
- ④ Shut-off valve, optional
- ⑤ Flow sensor
- ⑥ Centering ring

2.2.7 Free air delivery measurement - FAD (optional)

To create compressed air, a compressor draws in air from the ambient atmosphere, compresses it and delivers it at the required pressure. Since the ambient atmosphere also contains water vapour, the compressor draws in a mixture of air and water vapour. In addition to the moisture in the air, the ambient temperature and pressure conditions on the inlet side and the process conditions on the outlet side also influence the compressor capacity.

That is why most manufacturers specify compressor capacity as free air delivery at standard intake conditions. To compare the capacity of different compressors or to compare the capacity of a compressor at different points in time, the measurement of the air supplied by the compressor must be corrected by the influences of the process and of the environment and converted to these standardised suction conditions.

The vortex flowmeter with optional FAD function (FAD - Free Air Delivery) can measure the free air delivery online, regardless of its function as standard flowmeter. For this the device needs the process and ambient conditions, as well as the compressor data. When installed on the outlet side, it measures the air volume generated by the compressor and the process conditions. The menu-driven, user-friendly software prompts the operator to enter the following values:

- Ambient temperature (inlet)
- Atmospheric pressure (inlet)
- Air humidity (inlet and outlet)
- Motor speed (rated speed and actual speed)
- Pressure loss of the air filter

The FAD value is calculated from the measured and entered parameters using the vapour and compressibility tables stored in the measuring device.



INFORMATION!

- *For correct FAD measurement the compressor must run at full capacity.*
- *FAD measurement is an optional feature, which can be unlocked subsequently in menu "C6.3 Extras" if not unlocked by order.
Please contact the manufacturer to obtain the four digit code required to enable this feature.
For programming example refer to Settings for free air delivery measurement - FAD on page 84.*

2.2.8 Gross heat measurement (optional)

This functionality enables the calculation of the heat amount, which is carried by hot water, saturated or superheated steam in energy supply systems without external flow calculators.

The gross heat calculation is based on the temperature-dependent enthalpy of steam or hot water and the mass flow rate. The exact mass flow rate is measured by the vortex flowmeter, and the enthalpy tables are programmed in the device. The gross power flow rate is calculated within the device according to the following formula:

$$\text{Gross power } [Q_H] = \text{mass flow } [Q_m] \times \text{enthalpy } [H]$$

The absolute hot water and steam supply, as well as the energy, can be monitored internally via a totalizer by integration of the measured heat flow over time.



INFORMATION!

Heat quantity calculation is an optional feature, which can be unlocked subsequently in menu "C6.3 Extras" if not unlocked by order. Please contact the manufacturer to obtain the four digit code required to enable this feature.

For programming example refer to Gross heat measurement on page 85.

2.2.9 Net heat measurement (optional)

By installing a vortex flowmeter in the inlet line of a particular system section and adding an additional temperature sensor in the return section, the amount of energy, which is consumed by the considered system section can be determined directly by the vortex flowmeter. The temperature value can be fed into the vortex flowmeter either via the current input or via HART®.

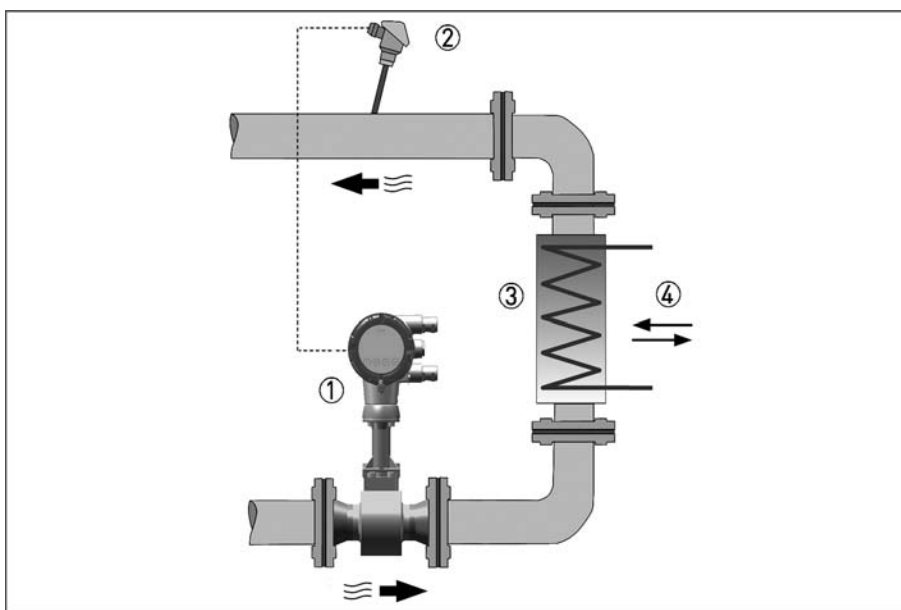

Figure 2-6: Measuring heat difference

- ① Flowmeter with built-in temperature sensor
- ② Temperature sensor
- ③ Heat exchanger
- ④ Heat flow



INFORMATION!

- *The net heat measurement can be realised for the inlet line media saturated steam, superheated steam and hot water. The medium in the return line must always be water.*
- *Heat quantity calculation is an optional feature, which can be unlocked subsequently in menu "C6.3 Extras" if not unlocked by order. Please contact the manufacturer to obtain the four digit code required to enable this feature. For programming examples refer to Net heat measurement on page 86.*

2.2.10 Dual seal

To comply with the requirements of ANSI/ISA 12.27.01 "Requirements for Process Sealing Between Electrical Systems and Flammable or Combustible Process Fluids", a membrane vent is integrated in the neck of the device. This vent is located between the primary seal (process) and the secondary seal (electronics compartment) and works to prevent pressure build-up in the device neck, thus preventing product from penetrating the electronics compartment in the unlikely event of a leak in the primary seal.

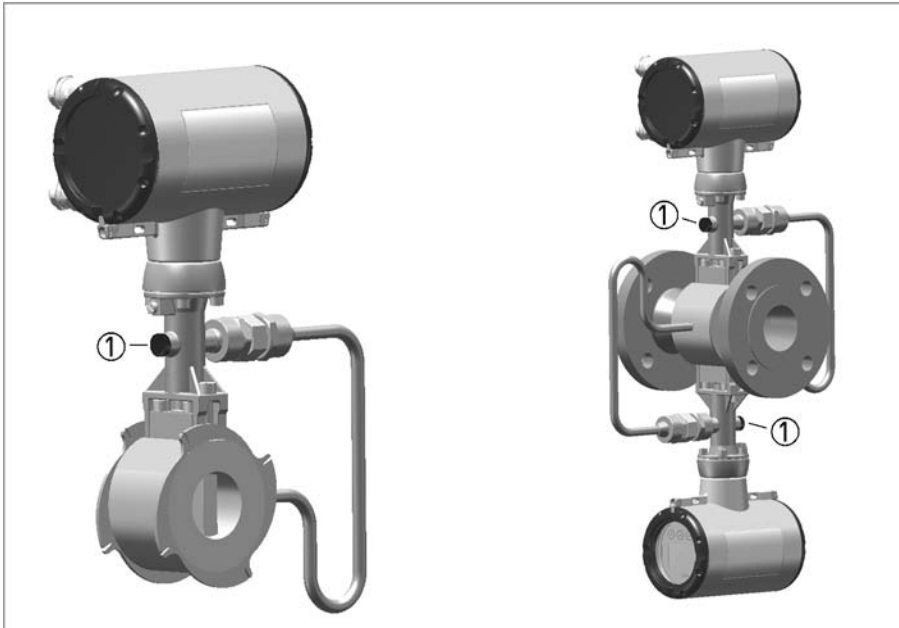

Figure 2-7: Dual Seal

① Membrane vent

The seal between the pick-up and the measuring tube is considered as the primary seal. The material used for this is always the same as that used for the measuring tube itself (e.g. 1.4435 / 316L for measuring tube made of stainless steel 1.4404 / 316L or Hastelloy[®] C-276 for measuring tube made of Hastelloy[®] C-22). When selecting the material, corrosion resistance depending on process parameters (product, temperature) must be taken into account. By using the membrane vent, all requirements for a "DUAL SEAL" version in terms of the above mentioned standards are met.

- It protects the electronics from the process media.
- Any leak in the primary seal can be detected.

Even though there is no reason to expect the seal to fail, regular visual checks should still be carried out to detect any possible leak as early as possible.

In the event of a leak, contact the manufacturer's service department to service or replace the device.

2.3 Nameplate



INFORMATION!

Check the device nameplate to ensure that the device is delivered according to your order. Check for the correct supply voltage printed on the nameplate.

②	③	④						
<p>KROHNE KROHNE Messtechnik GmbH 47058 Duisburg Germany</p>								
①	<p>OPTISWIRL 4200C Sensor: F1R MD: 2014</p> <p>PA: 012345678.001 DN50 PN100</p> <p>SN: D080000123456789 1.4435(316L)</p> <p>ER 1.1.1P2014 K-factor: 123,12 Pulse/m3</p>							
⑦	⑥							
<p> PTB 01 ATEX 2181 PED/G1/3.3/SEP</p> <p>II2GD EEx ia IIC T6 IP 66/67 PTmax: 84 bar</p> <p>II3GD IIC PS: 50 bar</p> <p>Tamb:-20°C...+60°C (T6: +xx°C) TS: 200 °C</p>								
⑧	<table style="width: 100%;"> <tr> <td>C1/C2 Ui = 30V li = 100mA</td> <td>Steam</td> </tr> <tr> <td>M1(3) / M2(4) Pi = 1W Ci = 15nF</td> <td>4.67353 kg/m3</td> </tr> <tr> <td>I1 / I2 Li = 600μH</td> <td>175.4 °C</td> </tr> </table>		C1/C2 Ui = 30V li = 100mA	Steam	M1(3) / M2(4) Pi = 1W Ci = 15nF	4.67353 kg/m3	I1 / I2 Li = 600μH	175.4 °C
C1/C2 Ui = 30V li = 100mA	Steam							
M1(3) / M2(4) Pi = 1W Ci = 15nF	4.67353 kg/m3							
I1 / I2 Li = 600μH	175.4 °C							
⑨	<p>Tag-No.: FIT-5436RES 7.5 bar</p>							
<p> → www.krohne.com </p>								

Figure 2-8: Example of nameplate

- ① Meter type
- ② Manufacturer
- ③ Flow sensor
S - Sandwich
F - Flange
F1R - Flange, single reduction
F2R - Flange, double reduction
- ④ Notified bodies for PED & ATEX (only available if this option was ordered)
- ⑤ Connection data: nominal diameter and pressure rating
- ⑥ PED data
- ⑦ Ex data (only available if this option was ordered)
- ⑧ Electrical connection data
- ⑨ Tag no. - Measuring point identifier

①	SN: D06000000100000
②	SO: nnnnnn/nnn
③	PA: nnnnnnnnnnn
④	nnnnnnnnnnnnnnnnnnnnnnnnnnnnnn
⑤	AC: nnnnnnnnnnn

Figure 2-9: Example of nameplate

- ① Serial number
- ② Order number
- ③ Production order number
- ④ Type code
- ⑤ Article code

3.1 General notes on installation



INFORMATION!

Inspect the packaging carefully for damages or signs of rough handling. Report damage to the carrier and to the local office of the manufacturer.



INFORMATION!

Do a check of the packing list to make sure that you have all the elements given in the order.

3.2 Storage

- Store the device in a dry, dust-free location.
- Avoid extended direct exposure to the sun.
- Store the device in the original packaging.
- The permissible storage temperature for standard devices is $-40\dots+85^{\circ}\text{C}$ / $-40\dots+185^{\circ}\text{F}$.

3.3 Transport

- Use lifting straps wrapped around both process connections for transport.
- Do not lift measuring devices by the signal converter housing for transport.
- Never lift the measuring device by the pressure sensor.
- Do not use lifting chains as they may damage the housing.

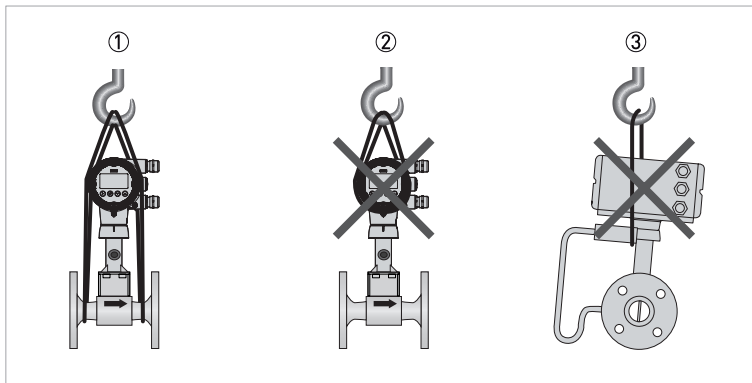

Figure 3-1: Transport instructions



CAUTION!

Non-secured devices can pose risk of injury. The centre of mass of the device is often higher than the point at which the lifting straps are attached. Prevent the measuring device from sliding or rotating accidentally.

3.4 Installation conditions

**INFORMATION!**

For accurate volumetric flow measurement the measuring device needs a completely filled pipe and a fully developed flow profile.

**CAUTION!**

Any vibrations may distort the measuring result. That is why any vibrations in the pipeline must be prevented through suitable measures.

**CAUTION!****Procedures to carry out before installing the device:**

- *Nominal diameter of connection pipe flange = nominal flange diameter of pipe!*
- *Use flanges with smooth holes, e.g. welding neck flanges.*
- *Align carefully the holes of the connecting flange and the flowmeter flange.*
- *Check the compatibility of the gasket material with the process product.*
- *Make sure that the gaskets are arranged concentrically. The flange gaskets must not project into the pipe cross-section.*
- *The flanges have to be concentric.*
- *There must not be any pipe bends, valves, flaps or other internals in the immediate inlet run.*
- *Devices in sandwich version may only be installed using centering rings.*
- *Never install the device directly behind piston compressors or rotary piston meters.*
- *The device must not be heated by radiated heat (e.g. exposure to the sun) to a electronics housing surface temperature above the maximum permissible ambient temperature. If it is necessary to prevent damage from heat sources, a heat protection (e.g. sun shade) has to be installed.*
- *Do not lay signal cables directly next to cables for the power supply.*
- *At product temperatures or ambient temperatures $>+65^{\circ}\text{C}$ / $+149^{\circ}\text{F}$, a connection cable and cable glands with a minimum service temperature of $+80^{\circ}\text{C}$ / $+176^{\circ}\text{F}$ must be used.*

**INFORMATION!**

If there is a risk of water hammers in steam networks, appropriate condensate separators must be installed. Suitable measures must be taken to avoid water cavitation if it is a possible risk.

3.4.1 Prohibited installation when measuring liquids

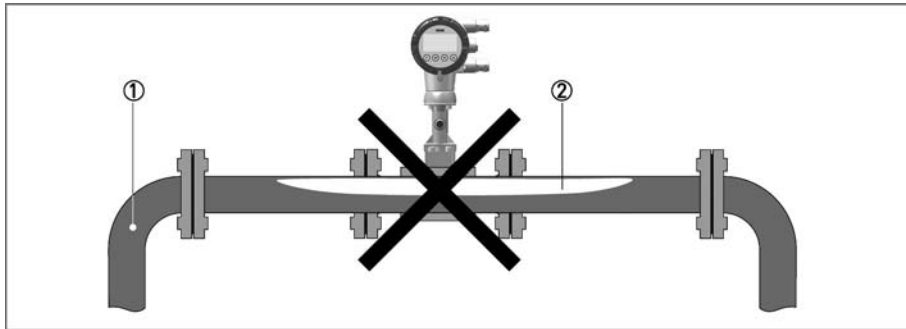

Figure 3-2: Upper pipe bend



CAUTION!

Prohibited: Installing the device in an upper pipe bend ①, because there is a risk of gas bubbles ② forming. Gas bubbles can lead to pressure surges and inaccurate measurement.

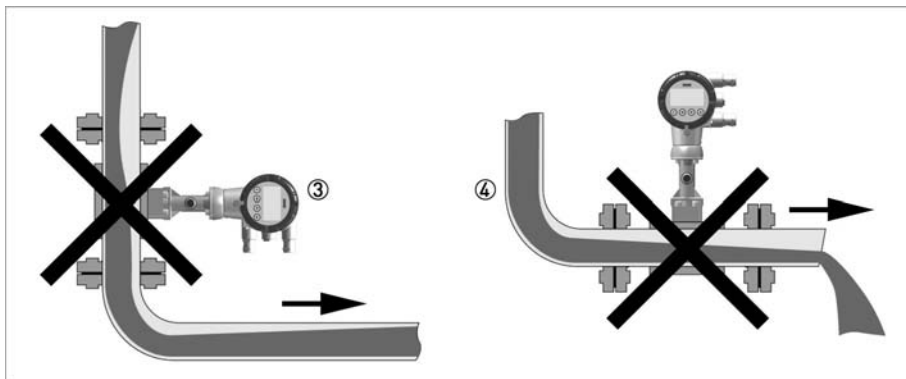

Figure 3-3: Downstream pipe and outlet



CAUTION!

Installing the device in a downstream pipe ③ or upstream pipe of an outlet ④. There is the risk of partially filled pipes leading to inaccurate measurements.

3.4.2 Prohibited installation when measuring steam and gases

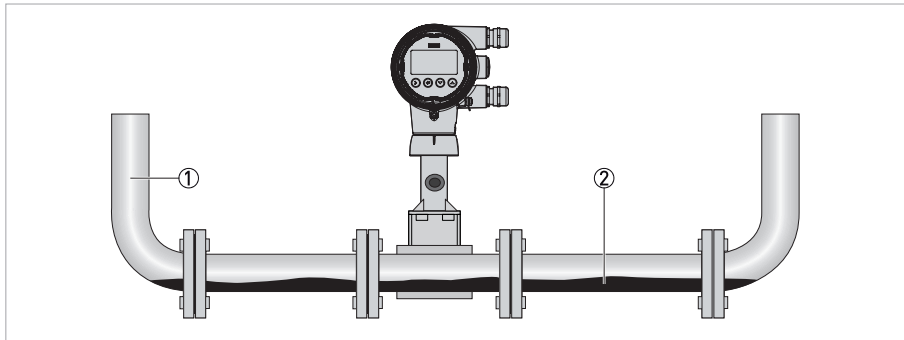

Figure 3-4: Prohibited installation when measuring steam and gases

- ① Lower pipe bends
- ② Condensate

**DANGER!**

Prohibited: Installing the device in a lower pipe bend ①, because there is a risk of condensate forming ②.

Condensate can lead to cavitation and inaccurate measurement. Under certain circumstances the device can be destroyed and the measured medium can leak.

3.4.3 Pipelines with control valve

**INFORMATION!**

To ensure smooth and correct measurement, the manufacturer recommends not installing the measuring device downstream from a control valve. This would run the risk of vortex formation, which would distort the measuring result.

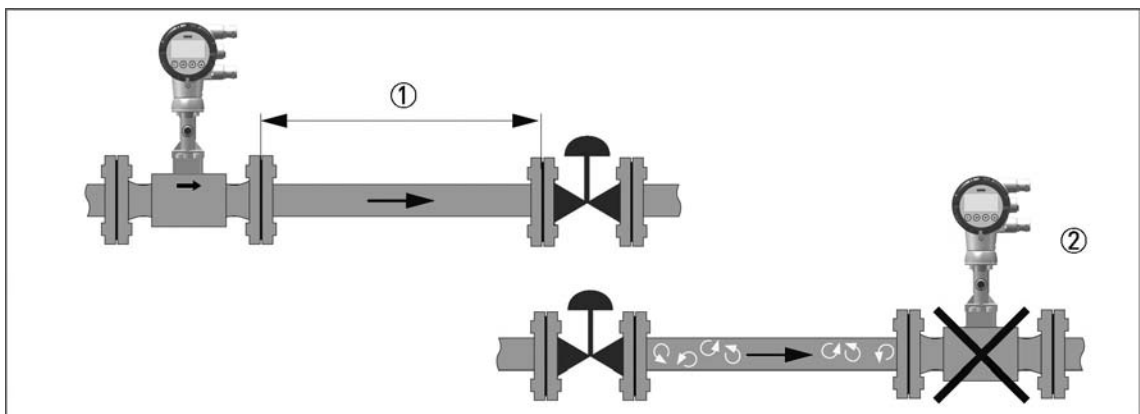

Figure 3-5: Pipelines with control valve

- ① Recommended: installing the device before the control valve at a distance of ≥ 5 DN
- ② Not recommended: Installing the flowmeter directly downstream of control valves, due to vortex formation.

3.4.4 Preferred mounting position

Preferred mounting position

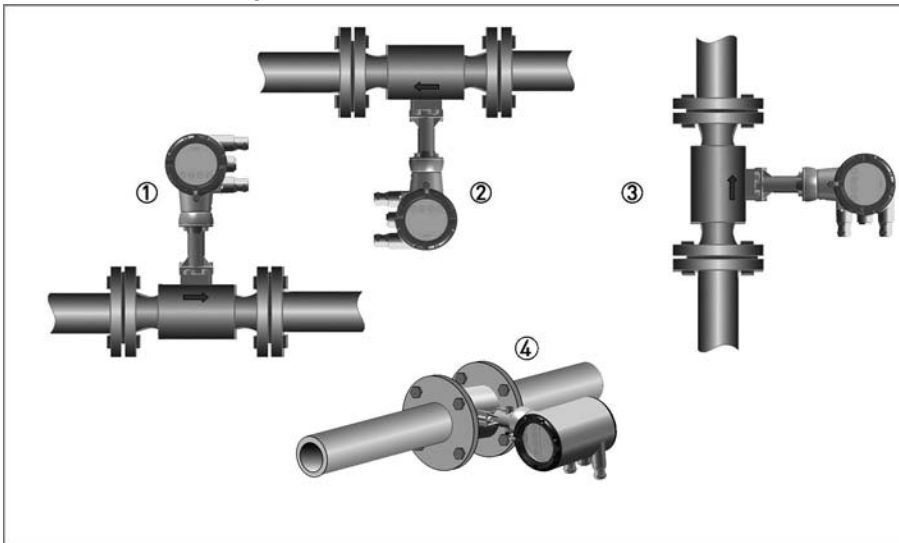

Figure 3-6: Mounting position

- ① Above a horizontal pipe
- ② Underneath a horizontal pipe (not permitted with lines at risk of condensate forming)
- ③ On a vertical pipe
- ④ Horizontal pipeline with signal converter-orientation 90° to the side



INFORMATION!

Depending on the installation position, you may have to rotate the display and/or the connection housing.

3.5 Minimum inlet sections

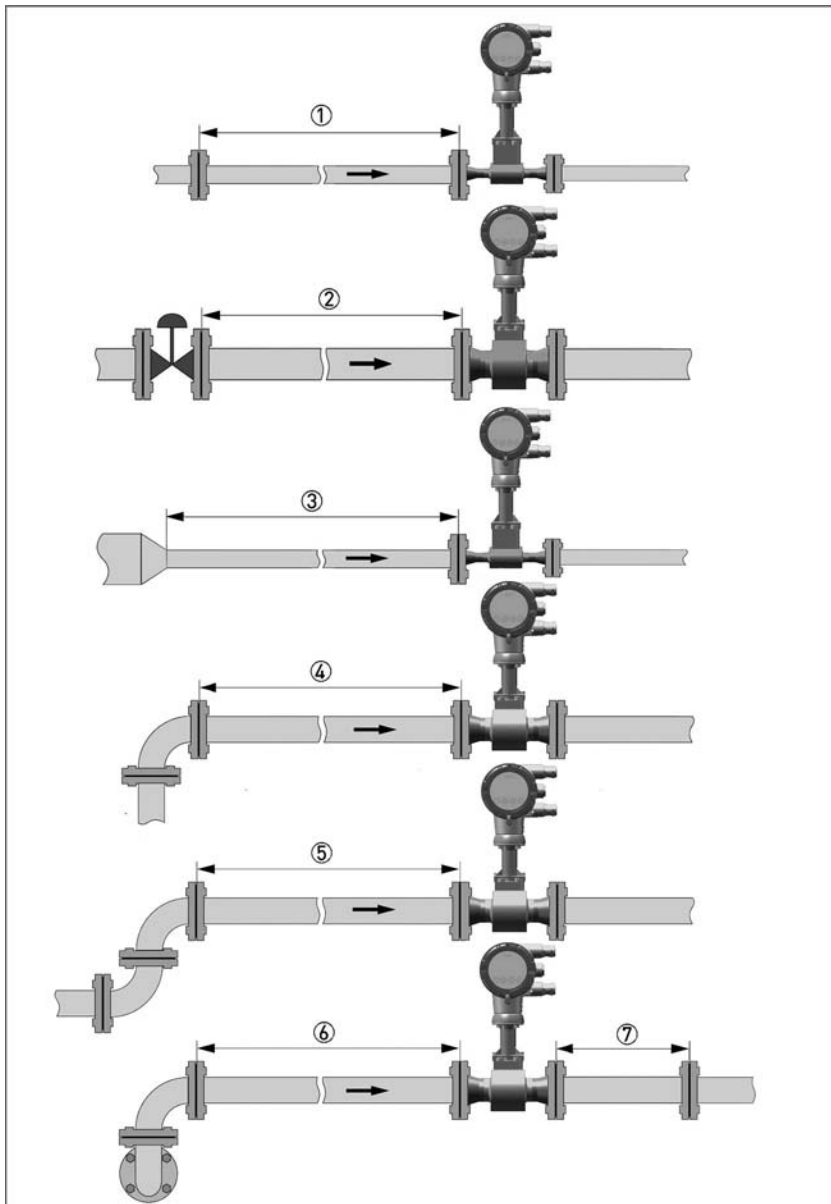

Figure 3-7: Minimum inlet sections

- ① General inlet section without disturbing flow ≥ 15 DN
- ② After a control valve ≥ 50 DN
- ③ After a pipe diameter reduction ≥ 20 DN
- ④ After a single bend $90^\circ \geq 20$ DN
- ⑤ After a double bend $2 \times 90^\circ \geq 30$ DN
- ⑥ After a double three-dimensional bend $2 \times 90^\circ \geq 40$ DN
- ⑦ Outlet section: > 5 DN



INFORMATION!

The nominal diameter of the flange is significant for the determination of the minimum inlet and outlet sections for the nominal diameter reduced versions of vortex flowmeter versions F1R and F2R.

3.6 Minimum outlet sections

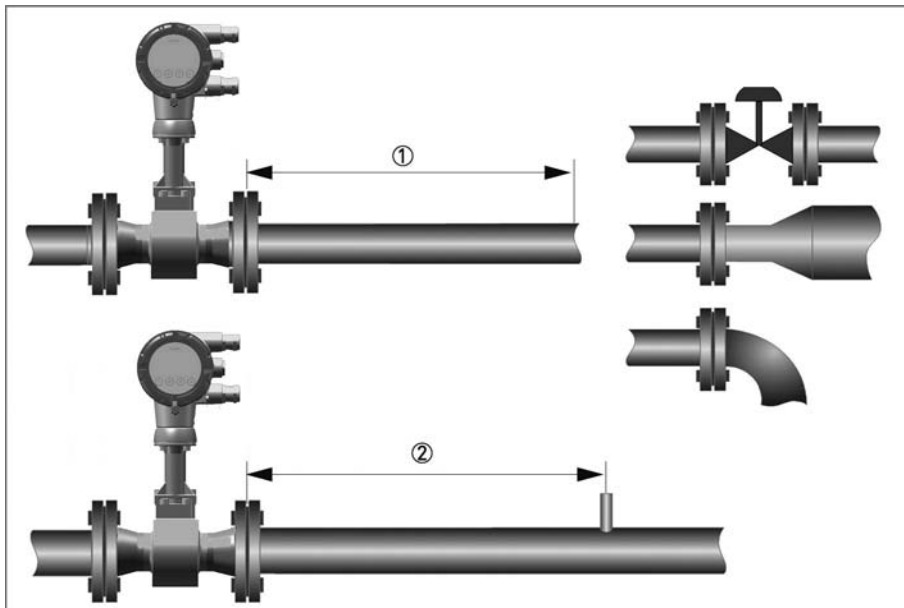

Figure 3-8: Minimum outlet sections

- ① Upstream of pipe expanders, pipe bends, control valves, etc. ≥ 5 DN
- ② Upstream of measuring points ≥ 5 DN



INFORMATION!

The interior of the pipe at the metering points must be free of burrs and other flow impediments. The measuring device has an internal temperature sensor. The distance from external temperature measuring points must be ≥ 5 DN. Use flow sensors that are as short as possible to avoid disturbances of the flow profile.

3.7 Flow straightener

If, due to the type of installation, the required inlet sections are not available, the manufacturer recommends using flow straighteners. Flow straighteners are installed between two flanges upstream of the device and shorten the required inlet section.

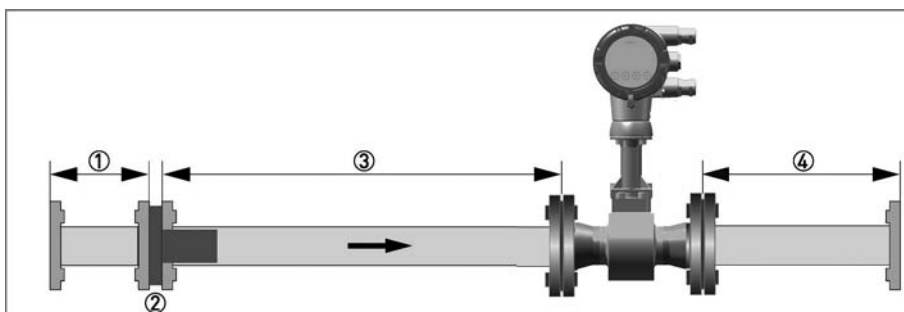

Figure 3-9: Flow straightener

- ① Straight inlet section upstream of straightener ≥ 2 DN
- ② Flow straightener
- ③ Straight pipe run between flow straightener and device ≥ 8 DN
- ④ Minimum straight outlet section ≥ 5 DN

3.8 Installation

3.8.1 General installation notes



CAUTION!

Installation, assembly, start-up and maintenance may only be performed by appropriately trained personnel. The regional occupational health and safety directives must always be observed.



The following procedures have to be carried out before installing the device:

- Ensure that the gaskets have the same diameter as the pipelines.
- Note the correct flow direction for the device. This is indicated by an arrow on the neck of the flow sensor.
- On measuring points with varying thermal loads, the devices have to be mounted with stress bolts (DIN 2510).
- Stress bolts or bolts and nuts are not included in the scope of delivery.
- Ensure that the measuring flange is concentrically fitted.
- Note the exact installation length of the measuring device when preparing the measuring point.

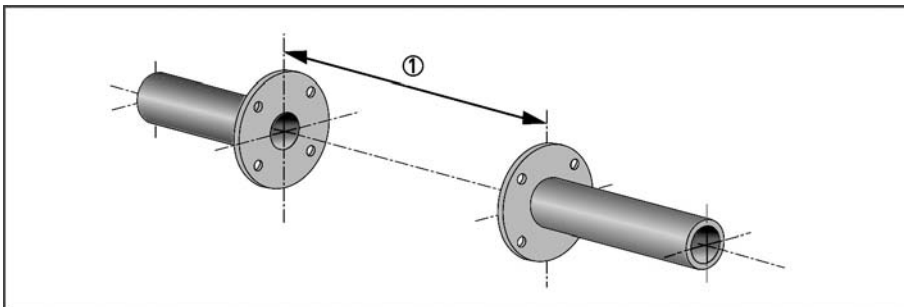

Figure 3-10: Preparing the metering point

- ① Installation length of measuring device + thickness of gaskets.



CAUTION!

The internal diameter of the pipelines, the flow sensor and the gaskets must match. The gaskets may not protrude into the flow.

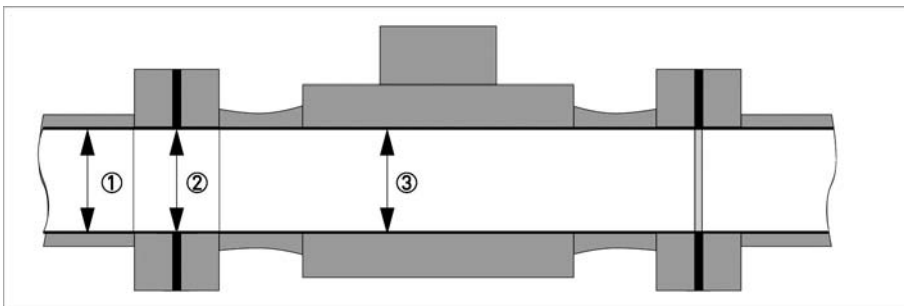

Figure 3-11: Inner diameter

- ① Inner diameter of connection pipe
 ② Inner diameter of flange and gasket
 ③ Inner diameter of flow sensor

3.8.2 Installing devices in sandwich design

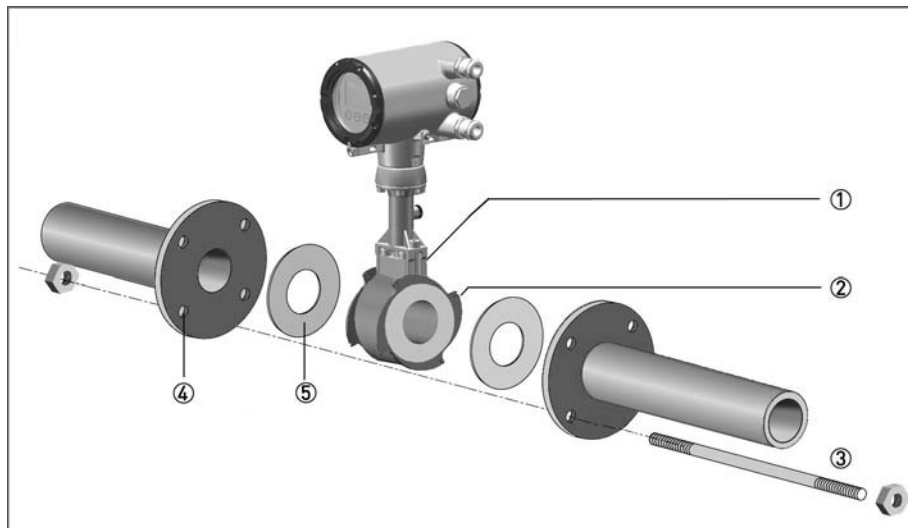

Figure 3-12: Installation using centering ring

- ① Flow sensor
- ② Centering ring
- ③ Bolts with fixing nuts
- ④ Drill hole
- ⑤ Sealing



- Push the first bolt ③ through the hole ④ of both flanges.
- Screw on the nuts and washers to both ends of the bolt ③ but do not tighten them.
- Install the second bolt through the holes ④.
- Place the flow sensor ① between the two flanges.
- Insert the gaskets ⑤ between flow sensor ① and flanges and align them.
- Check that the flange is concentric.
- Install the remaining bolts, washers and nuts. Do not yet tighten the nuts.
- Turn the centering ring ② in a counter-clockwise direction and align the device.
- Check that the gaskets ⑤ are concentric; they must not protrude into the pipe cross-section.
- Now tighten all nuts bit by bit alternately across the diagonal.

3.8.3 Installing devices in flange design

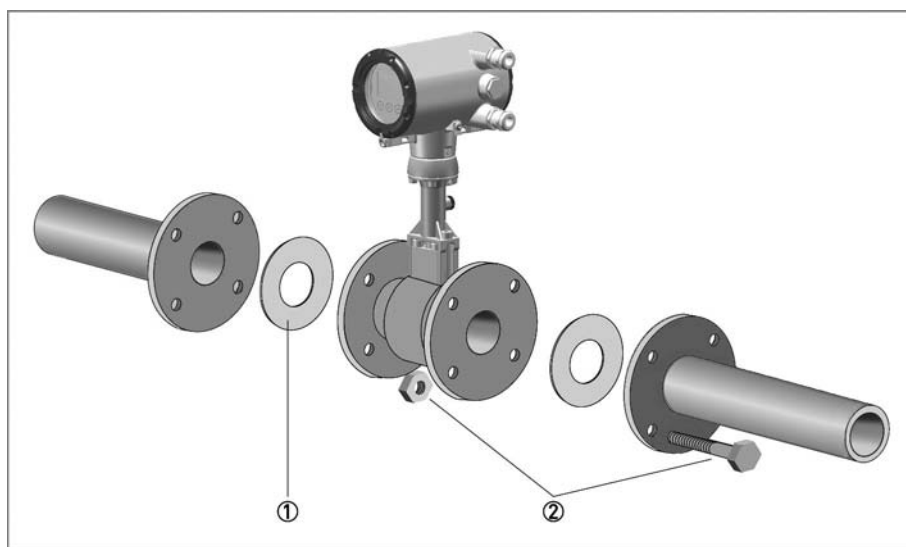

Figure 3-13: Installing devices in flange design

- ① Sealing
- ② Bolts with fastening nuts



- Use bolts and fastening nuts ② to attach the measuring device to one side of the flange.
- While doing so, insert the gaskets ① between flow sensor and flange and align them.
- Check that the gasket is concentric and that it is not protruding into the pipe cross-section.
- Install the gasket, bolts and fastening nuts on the other side of the flange.
- Align the measuring device and the gaskets so they are concentric.
- Now tighten all nuts bit by bit alternately across the diagonal.

3.8.4 Mounting the field housing, remote version



INFORMATION!

Assembly materials and tools are not part of the delivery. Use the assembly materials and tools in compliance with the applicable occupational health and safety directives.

Pipe mounting

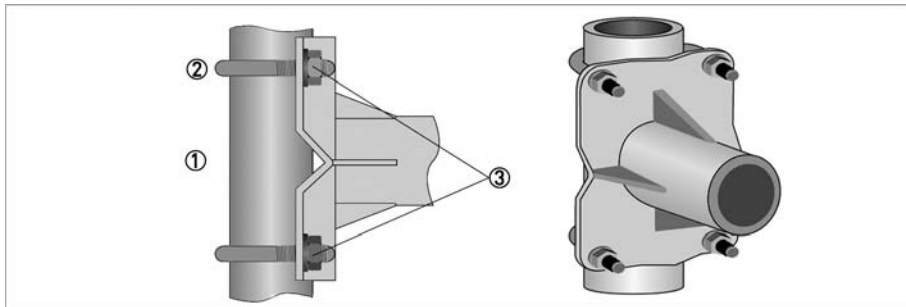

Figure 3-14: Pipe mounting of the field housing



- ① Fix the signal converter to the pipe.
- ② Fasten the signal converter using standard U-bolts and washers.
- ③ Tighten the nuts.

Wall mounting

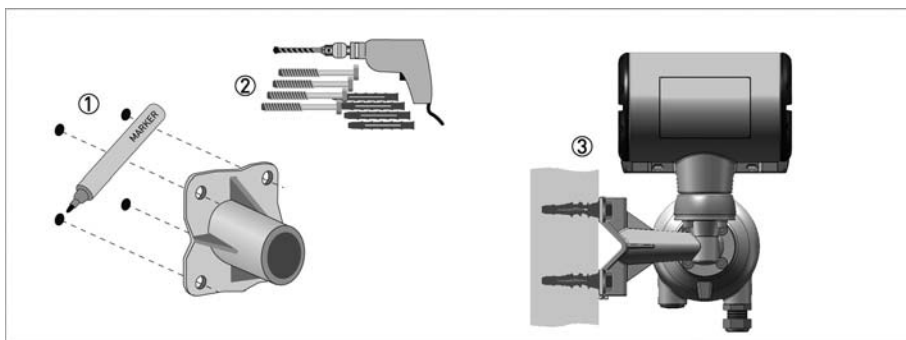

Figure 3-15: Wall mounting of the field housing



- ① Prepare the holes with the aid of the mounting plate.
- ② Use the mounting material and tools in compliance with the applicable occupational health and safety directives.
- ③ Fasten the housing securely to the wall.



INFORMATION!

Signal converters with a wall mounting rack have to be mounted with screws ($\varnothing 8$ mm / 0.3") or with U-brackets ($\varnothing 8$ mm / 0.3") in case of pole installation. In case of mounting directly to the wall, a mounting system with a minimum load force of 0.1 kN (for example FISCHER type UX10) suitable for the background has to be applied.

3.9 Heat insulation



CAUTION!

For applications with medium temperatures above +160°C / +320°F an insulation of the pipeline in accordance to the insulation guideline is suggested. Avoid higher electronic temperatures than +80°C / +176°F.

The area above the signal converter support must not be heat-insulated.

The heat insulation ③ may only extend to the maximum height ① shown below.

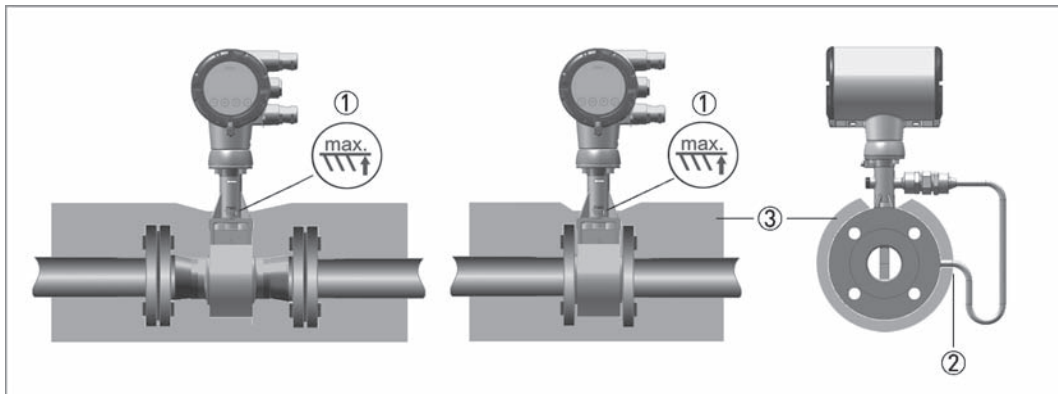

Figure 3-16: Installation heat insulation

- ① Max. height of the insulation up to the marking on the neck of the flow sensor
- ② Max. thickness of the insulation up to the bend of the pressure pipe
- ③ Insulation



CAUTION!

The heat insulation ③ may only extend as far as the bend of the pressure sensing line ②.

3.10 Turning the connection housing

**DANGER!**

All work on the device electronics may only be carried out by appropriately trained personnel.
The regional occupational health and safety directives must always be observed.

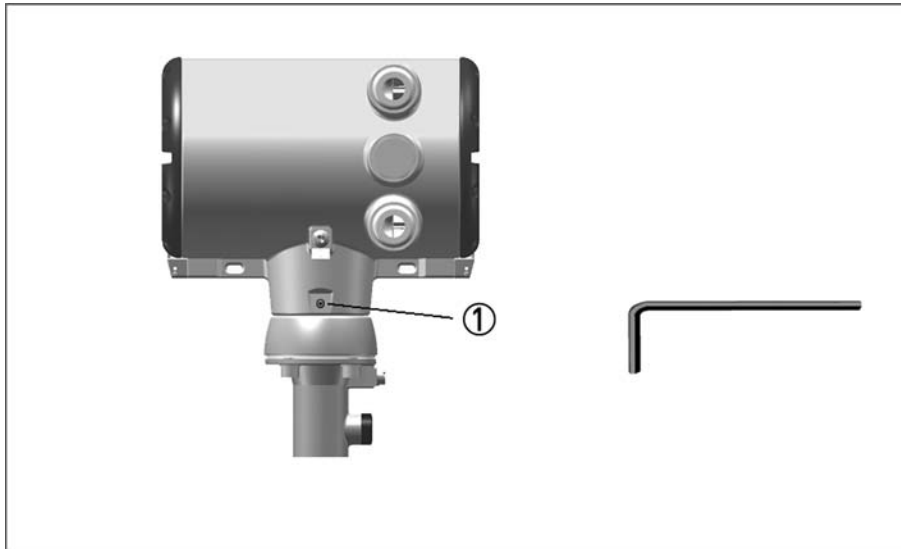

Figure 3-17: Turning the connection housing

① M4 Allen screw on connection housing



- Loosen the M4 Allen screw ① on the side of the connection housing.
- Rotate the connection housing to the desired position (0...360°).
- Tighten the M4 Allen screw ① again.

3.11 Turning the display

**DANGER!**

All work on the device electronics may only be carried out by appropriately trained personnel. The regional occupational health and safety directives must always be observed.

**INFORMATION!**

If the measuring device is installed in a vertical pipe, you will have to turn the display by 90°; if installed below a pipe, turn 180°.

**INFORMATION!**

The display can be turned in increments of 90° to four positions.

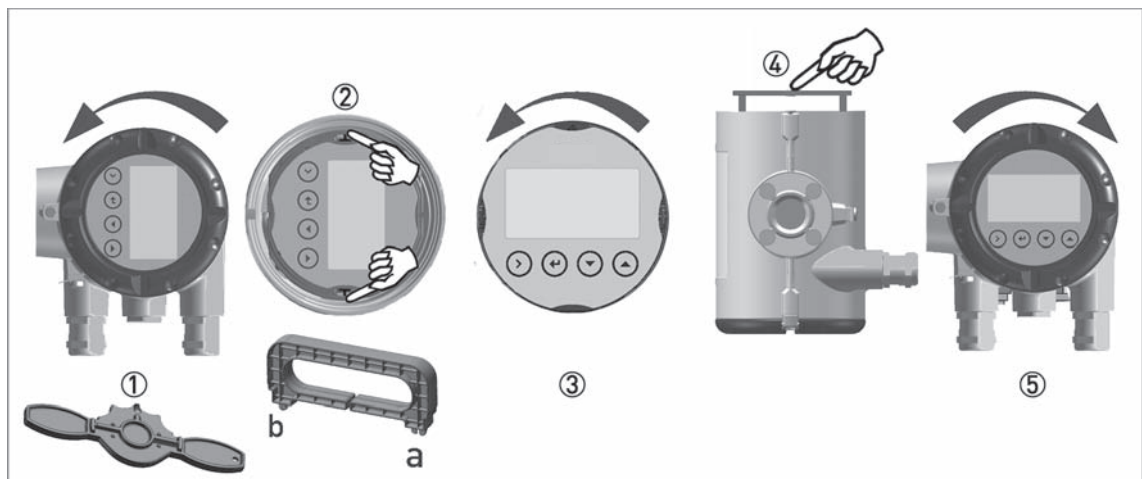

Figure 3-18: Turning the display

**Turn the display as follows:**

- Disconnect the power supply from the measuring device.
- Unscrew the housing cover with the key ①.
- Please use the handle to pull out the display module.
- First put the handle on side "a" and then on side "b" of the display, and then pull out the display ② carefully. Turn it into the favoured position ③.
- Disconnect the display from the handle first on side "a" and then on side "b".
- Press the display onto the spacer pins ④, until it clicks.
- Turn the cover with gasket ⑤ back onto the housing and tighten it by hand.

**INFORMATION!**

Before closing the housing cover refer to *Maintaining the O-rings* on page 95.

4.1 Safety instructions

**DANGER!**

All work on the electrical connections may only be carried out with the power disconnected. Take note of the voltage data on the nameplate (for details refer to Nameplate on page 22).

**DANGER!**

Observe the national regulations for electrical installations!

**DANGER!**

For devices used in hazardous areas, additional safety notes apply; please refer to the Ex documentation.

**WARNING!**

Observe without fail the local occupational health and safety regulations. Any work done on the electrical components of the measuring device may only be carried out by properly trained specialists.

**INFORMATION!**

Check the device nameplate to ensure that the device is delivered according to your order. Check for the correct supply voltage printed on the nameplate.

4.2 Connecting the signal converter



DANGER!

All work on the electrical connections may only be carried out with the power disconnected. Take note of the voltage data on the nameplate!



INFORMATION!

When using the binary output M1...M4 as pulse output and frequencies above 100 Hz, shielded cables are to be used in order to reduce effects from electrical interferences (EMC).

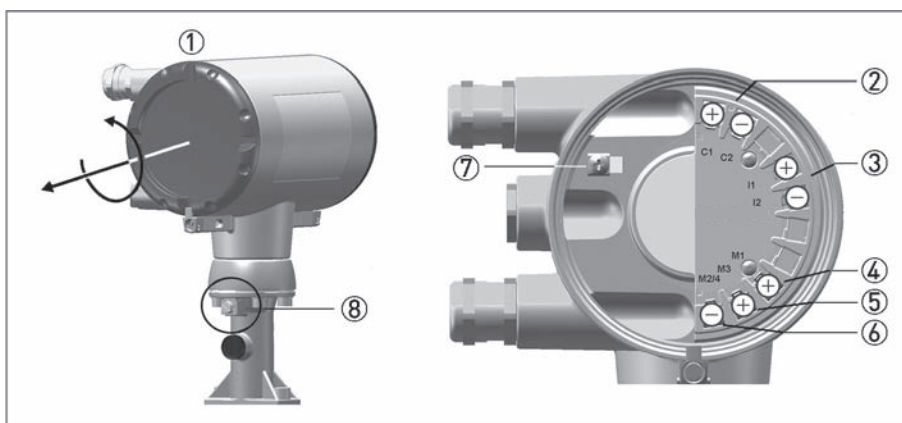

Figure 4-1: Connecting the signal converter

- ① Open the housing cover of the electrical terminal compartment using the key
- ② Signal converter supply and 4...20 mA loop
- ③ 4...20 mA current input, - external transmitter, optional
- ④ Terminal M1 binary (high current)
- ⑤ Terminal M3 binary (NAMUR)
- ⑥ Terminal M2/4 binary, common minus connection
- ⑦ Ground terminal in housing
- ⑧ Ground terminal on connection piece between flow sensor and signal converter



INFORMATION!

Both grounding terminals 7 and 8 are equally effective from a technical point of view.



Steps for connecting the signal converter:

- Unscrew the housing cover ① of the electrical terminal compartment.
- Feed the connection cable through the cable entry in the housing.
- Connect the cable according to the terminal diagrams below.
- Connect the grounding to the terminal ⑦. Alternatively use the ground terminal ⑧ on the connection piece between the flow sensor and the signal converter.
- Tighten the cable glands.
- Turn the housing cover and gasket back onto the housing and tighten it by hand.



INFORMATION!

Ensure that the housing gasket is properly fitted, clean and undamaged.
Before closing the housing cover refer to Maintaining the O-rings on page 95.

4.3 Electrical connections

The signal converter is a 2-wire device with 4...20 mA as output signal. All other inputs and outputs are passive and always require an additional power supply.

4.3.1 Power supply

All versions are intended for connection to limited-energy circuits of max. 36 VDC / 4 A.



INFORMATION!

The supply voltage has to be between 12 VDC and 36 VDC (12...30 VDC for Ex). This is based on the total resistance of the measuring loop. To calculate this, the resistance of each component in the measuring loop (not including the device) must be added up.

The required supply voltage can be calculated using the formula below:

$$U_{\text{ext.}} = R_L \cdot 22 \text{ mA} + 12 \text{ V}$$

with

$U_{\text{ext.}}$ = minimum supply voltage

R_L = total measuring loop resistance



INFORMATION!

The power supply has to be able to supply a minimum of 22 mA.

4.3.2 Current output

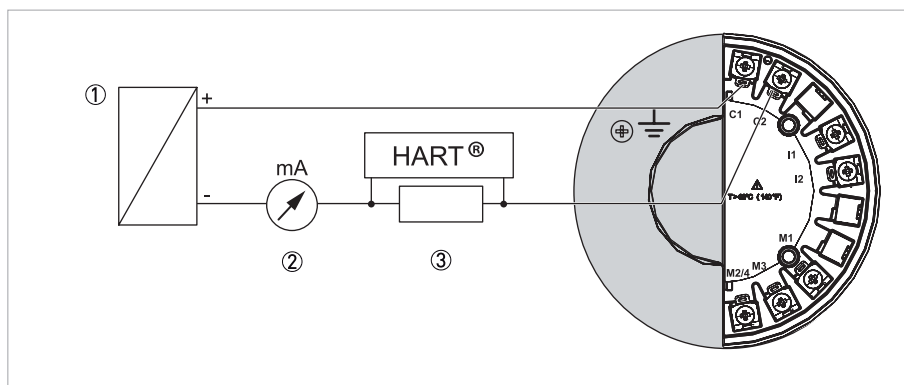

Figure 4-2: Electrical connection current output

- ① Power supply for current output
- ② Optional display unit [R_L]
- ③ Load for HART® $\geq 250 \Omega$

Connect current loop 4..20 mA to terminals C1+ and C2-.

When connection cables are long, a shielded or twisted cable may be necessary. The cable shield may only be grounded at one place (e.g. on the power supply unit).

4.3.3 Current input

An external transmitter, e.g. temperature or pressure transmitter, can be connected to terminals I1+ and I2-. The 4...20 mA current signal is converted to the corresponding temperature or pressure value in the signal converter.

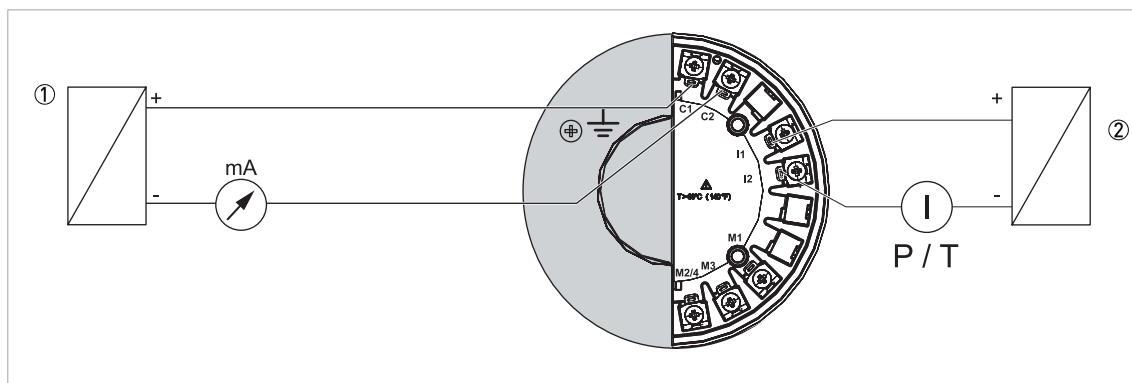

Figure 4-3: Electrical connection current input

- ① Power supply for the signal converter
- ② Current input of an external temperature or pressure transmitter

The current input can be configured in menu C1.5. Depending on the configuration of the current input, the sources for temperature and/or pressure value have to be adjusted in menu C1.6 or C1.7.

4.3.4 Binary output

Unless otherwise ordered, the binary output is inactive by default and must thus be activated and configured as limit switch output, pulse output, frequency output or status output in menu C2.2 prior to first use. The binary output is electrically separated from the current output and must be supplied with power separately.

4.3.5 Limit switch output

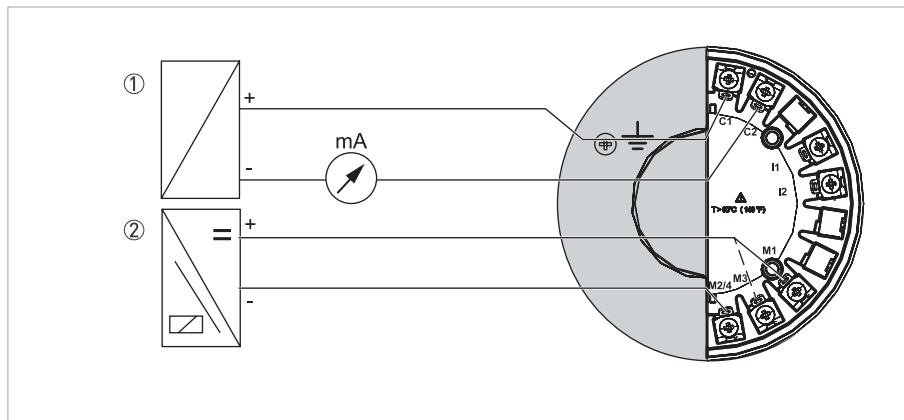

Figure 4-4: Connection binary output

- ① Power supply U_{ext} .
- ② Isolated switching amplifier



INFORMATION!

Binary output Mx can only be operated if the loop supply 4...20 mA is applied to the terminals $C1+$ and $C2-$. The binary output is inactive by default and must thus be activated in menu $C2.2$ prior to first use.

Connection binary output

In accordance with the desired signal transmission, select one of the following connection types for binary output M :

- $M2/4$ and $M3$ - NAMUR (DC interface in accordance with EN 60947-5-6)
- $M2/4$ and $M1$ - Transistor output (passive, open collector)

Terminal connection

Terminal	M1	M3	M2/4
Connection NAMUR		+ (open collector, $R_i \sim 1 \text{ k}\Omega$)	Common
Connection transistor output	+ (open collector, $I_{max} < 100 \text{ mA}$)		Common

Value range for NAMUR

	NC contact ①	NO contact ②
Switching value reached	< 1 mA	> 3 mA
Switching value not reached	> 3 mA	< 1 mA

① C2.2.6 Invert Signal On

② C2.2.6 Invert Signal Off

Value range applies only when connected to a switching amplifier with the following reference values:

- Open-circuit voltage $U_0 = 8.2 \text{ VDC}$
- Internal resistance $R_i = 1 \text{ k}\Omega$

Value range for transistor output

	U_L	I_L	U_H	I_H
via load R_L	0...2 V	0...2 mA	16...30 V	20...100 mA

To ensure the value ranges, a load R_L between 250Ω and $1 \text{ k}\Omega$ is recommended for the passive transistor output with a nominal voltage of 24 VDC. If other loads are used, caution is advised as the range of values of the signal voltages then no longer corresponds to the range of values for the inputs of process control systems and controls (DIN IEC 946).

**CAUTION!**

The upper limit of the signal current must not be exceeded as this may damage the transistor output.

For selection of measurement variable and adjustable data of the limit switch refer to chapter "Menu description C - Setup", menu "C2.2.5 Limit Switch" and appropriate submenus.

4.3.6 Pulse output / Frequency output

The maximum frequency of both pulse output and frequency output is 1000 Hz.

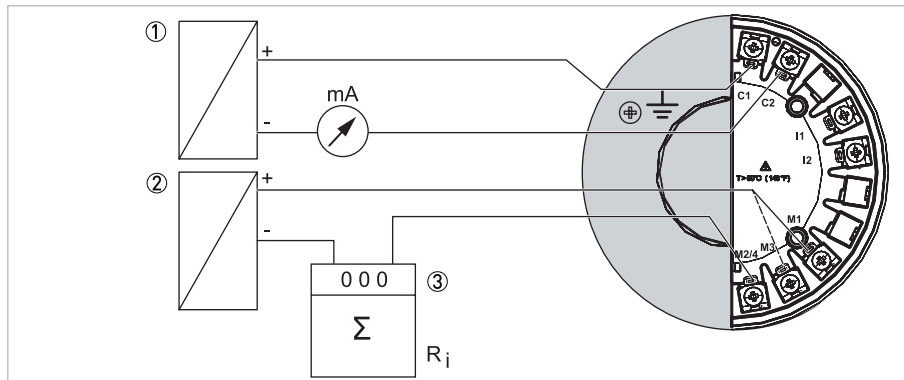

Figure 4-5: Electrical connection pulse output

- ① Signal converter power supply
- ② Pulse output power supply
- ③ Pulse counter or frequency meter

The connection is made between terminal M2/4 Common (-) and M1 for Hi Current (+) or M3 NAMUR (+). Only one of the two connections M1 or M3 can be selected in menu C2.2. The output is selected as pulse or frequency output in menu C2.2. The output is a passive "open collector" output which is electrically separated from the current interface and the flow sensor. It requires its own power supply ②. The total resistance must be adapted so that the total current I_{tot} does not exceed 120 mA.

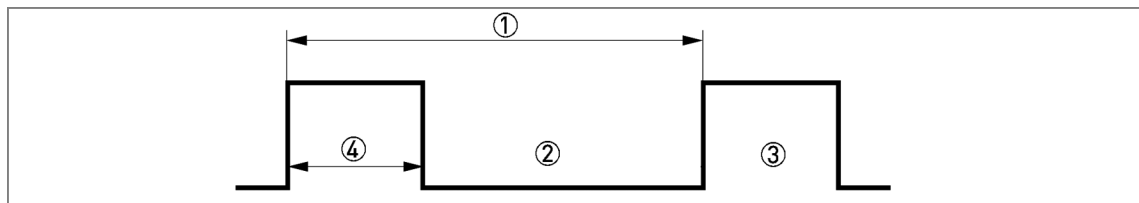

Figure 4-6: Pulse output signal definition

- ① T_{max}
- ② Closed
- ③ Open
- ④ Pulse width ≥ 0.5 ms

For selection of measurement variable and adjustable data of the pulse or frequency output refer to chapter "Menu description C - Setup", menu "C2.2.2 Pulse Output" or menu "C2.2.3 Frequency Output" and appropriate submenus.



INFORMATION!

Make sure the pulse width is in line with the pulse rate.

4.3.7 Status output

The + pole of the high current output is on the M1 terminal connection. The + pole of the NAMUR output is on the M3 connection terminal. Terminal M2/4 is the common - pole of the status output.

High current terminal M1...M2/4		
Open	Maximum voltage $U_{\max} = 36 \text{ VDC}$	Closed current $I_R < 1 \text{ mA}$
Closed	Maximum current $I_{\max} = 100 \text{ mA}$	Voltage $U < 2 \text{ VDC}$

NAMUR terminal M3...M2/4	
$R_T = 900 \Omega$	$U_{\max} = 36 \text{ VDC}$

For selection of status function and adjustable data of the status output refer to chapter "Menu description C - Setup", menu "C2.2.4 Status Output" and appropriate submenus.

4.4 Connection of remote version

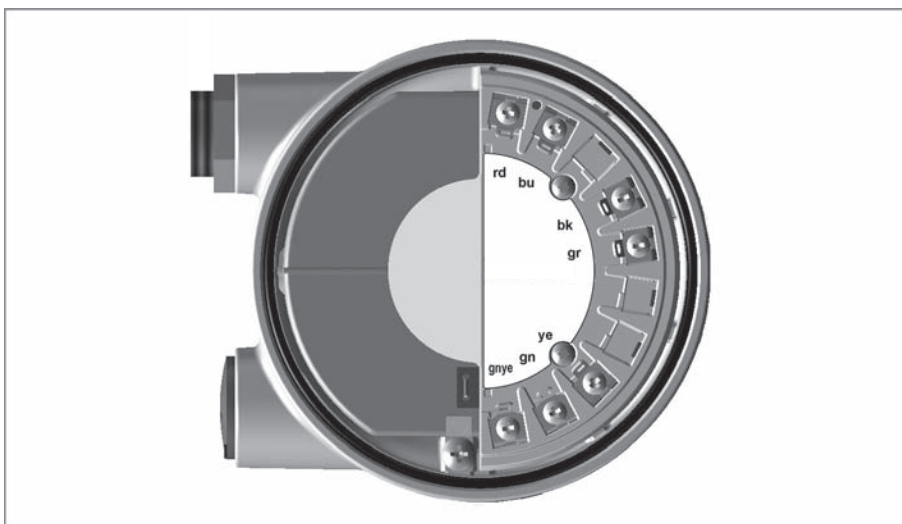

The connection terminals in the connection box of the flow sensor and the wall bracket are identical in construction.

Connection cable strand colour

Terminals	Strand colour
rd	red
bu	blue
bk	black
gr	grey
ye	yellow
gn	green
gnye	Shielding

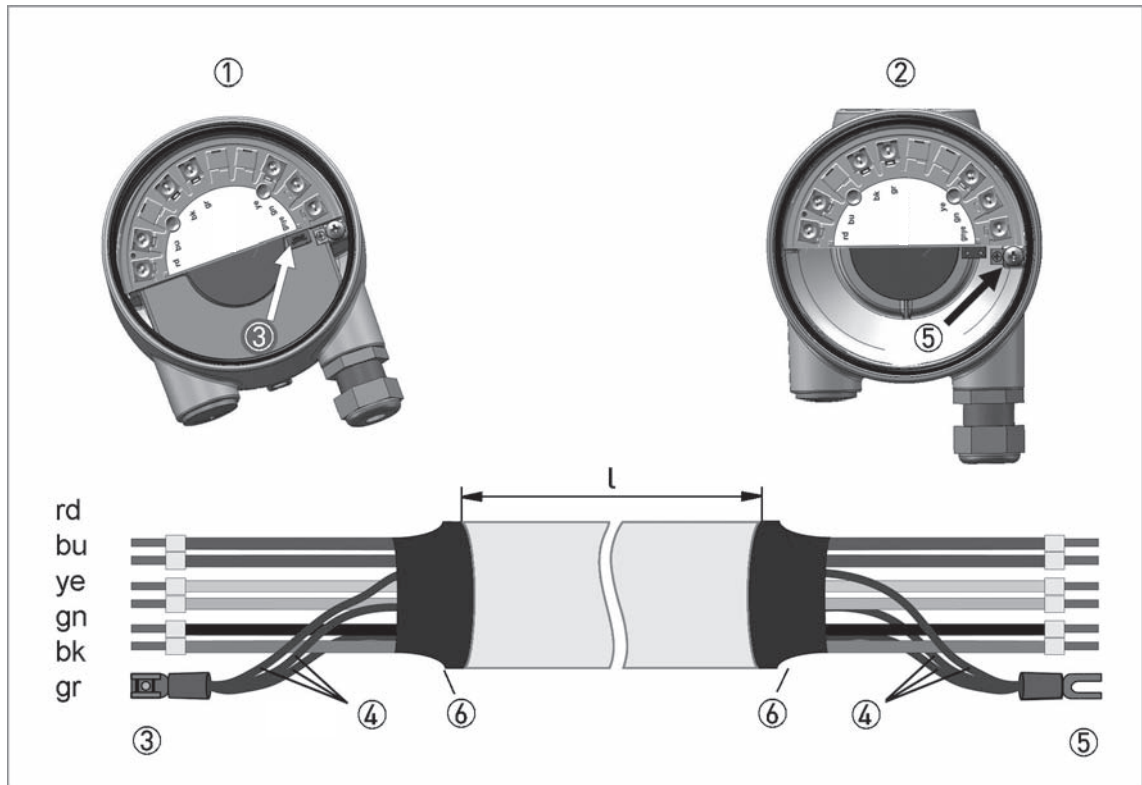

Figure 4-7: Connection of remote version

- ① Terminal connection of flow sensor
- ② Terminal connection of signal converter
- ③ Terminal end pair shielding of flow sensor
- ④ Filler wire pair shielding (protected with heat shrink tubing)
- ⑤ Fork clamp pair shielding on signal converter side
- ⑥ Heat shrink tubing

The maximum cable length is 50 m / 164 ft.

The cable can be shortened easily. All wires must be connected afterwards.



CAUTION!

Please ensure that the shielding ④ has been properly connected to both terminals ③ and ⑤. The exterior shielding of the cable must not be connected to any terminal.

4.5 Grounding connections

The grounding can be done either by connecting the PE (Protective Earth) terminal in the housing or the PE terminal on the connection piece between flow sensor and signal converter. Both of these electrical connections are equally effective from a technical point of view.

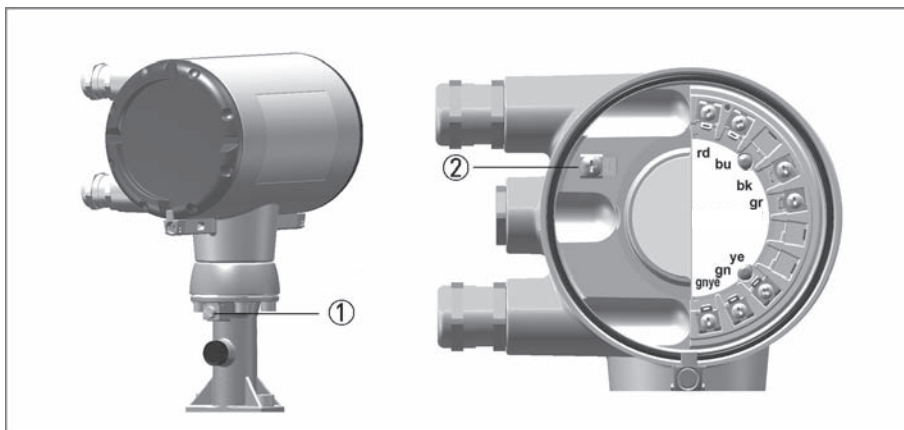

Figure 4-8: Ground connection compact version

- ① Electrical grounding connection on connection piece between flow sensor and signal converter.
- ② Electrical grounding terminal in the housing



CAUTION!

The measuring device has to be grounded properly to achieve accurate measurement. The grounding wire may not transfer any interference voltage. Do not use this grounding cable to ground any other electrical devices.

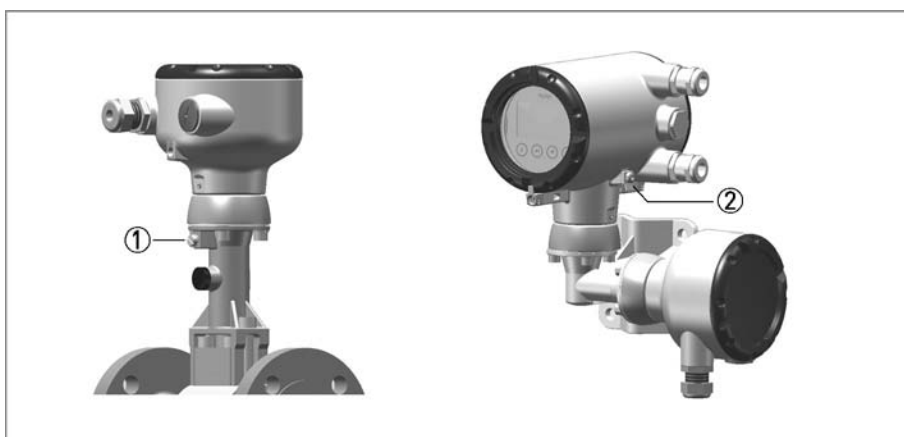

Figure 4-9: Ground connection remote version

- ① Electrical grounding connection on flow sensor
- ② Electrical grounding connection on signal converter housing



INFORMATION!

In the remote version, the flow sensor as well as the signal converter must be grounded.

4.6 Ingress protection

The signal converter electronics housing meets the requirements for IP66/67 in accordance with EN 60529 both for the compact and for the remote version.



CAUTION!

After all servicing and maintenance work on the measuring device, the specified ingress protection category must be ensured again.

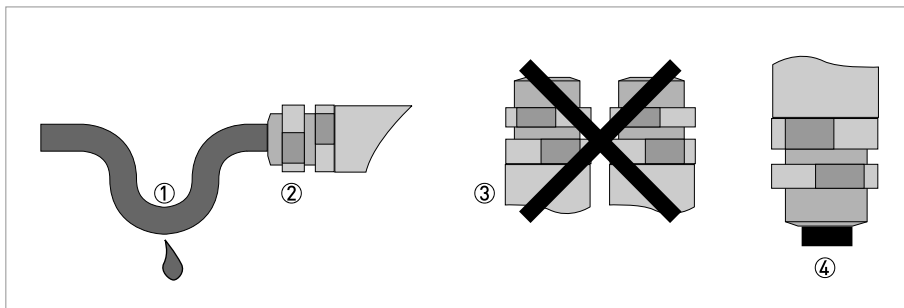

Figure 4-10: Cable feedthrough



Therefore it is essential to observe the following points:

- Use only original gaskets. They must be clean and free of any damage. Defective gaskets must be replaced.
- The electrical cables used must be undamaged and must comply with regulations.
- The cables must be laid with a loop ① upstream of the measuring device to prevent water from getting into the housing.
- The cable feedthroughs ② must be tightened. Note that the clamping range of the cable feedthrough corresponds to the outer diameter of the cable.
- Align the measuring device so that the cable feedthrough is never facing up ③.
- Close any unused cable feedthroughs using blind plugs ④ suitable for the protection category.
- Do not remove the required cable bushing from the cable feedthrough.

5.1 Start-up screen



INFORMATION!

After connection to power supply the device carries out a self-test. After 10 seconds the following start-up screen appears:

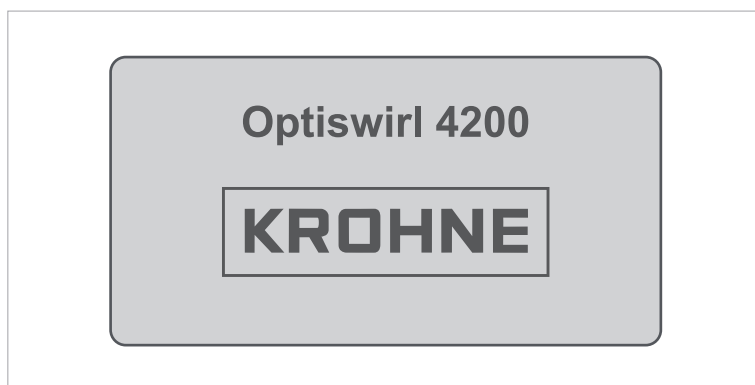

Figure 5-1: Start-up screen

After finishing of the self-test the device switches to the measuring mode. Here, all of the parameters preset for the customer are analysed and checked for plausibility, and the currently measured value is displayed.

5.2 Operation



INFORMATION!

*The measuring device is largely maintenance-free.
Observe the application limits in respect of temperature and medium.*

6.1 Display and operating elements

In case of an open front cover, the device is operated by using mechanical keys; in the case of a closed cover, a bar magnet ① is used.

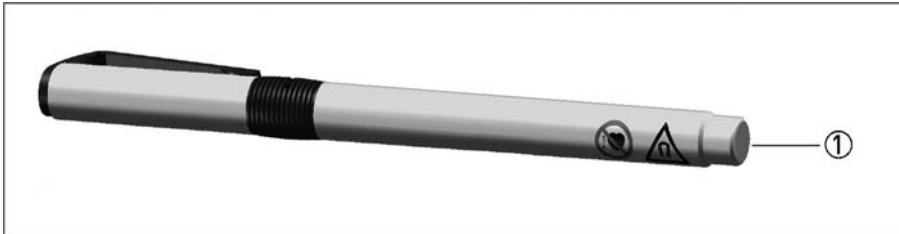

Figure 6-1: Pen with bar magnet



CAUTION!

The switching point of the magnetic sensors is directly under the glass panel above the appropriate symbol. Touch the symbol only vertically and from the front. Touching it from the side may cause a malfunction.

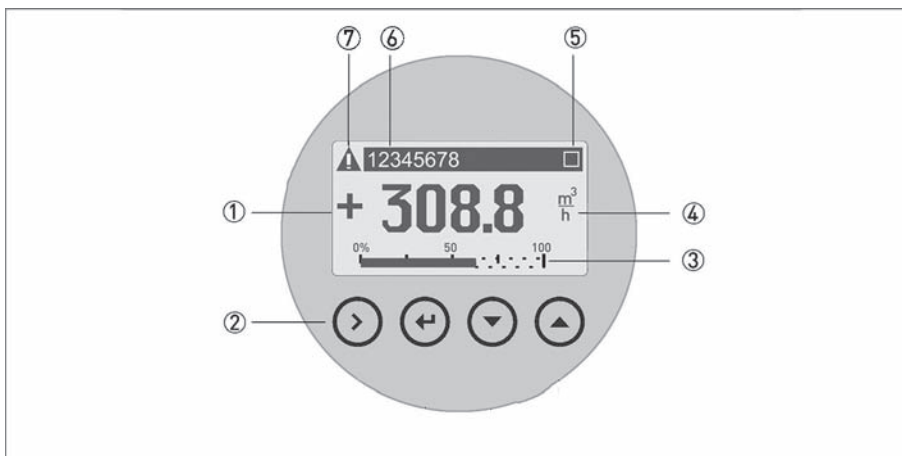

Figure 6-2: Display and operating elements

- ① Display
- ② Mechanical keys and bar magnet
- ③ Bargraph indication
- ④ 1st measured variable in large representation
- ⑤ Indicates when a key has been pressed
- ⑥ Tag number (only shown if entered previously by the operator)
- ⑦ Indicates a possible status message in the status list

The mechanical keys and keys for the bar magnet have the same functionality. In this documentation the keys are represented as symbols to describe the operating functions:





Mechanical and bar magnet	Symbol
	→
	←
	↓
	↑

Table 6-1: Description of keys

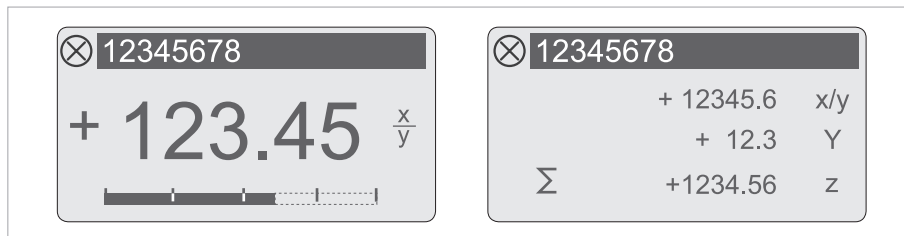

Figure 6-3: Displays in measuring mode (examples for 2 or 3 measured values)
x, y and z denote the units of the measured values displayed

6.1.1 Display for selection of submenu and functions, 3 lines

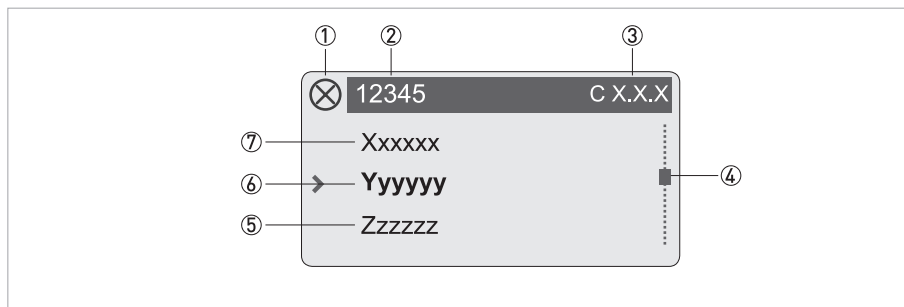

Figure 6-4: Display for selection of submenu and functions, 3 lines

- ① Indicates a possible status message in the status list
- ② Menu, submenu or function name
- ③ Number relating to ⑥
- ④ Indicates position within menu, submenu or function list
- ⑤ Next menu(s), submenu or function
[__ signals in this line the end of the list]
- ⑥ Current menu(s), submenu or function
- ⑦ Previous menu(s), submenu or function
[__ signals in this line the beginning of the list]

6.1.2 Display when setting parameters, 4 lines

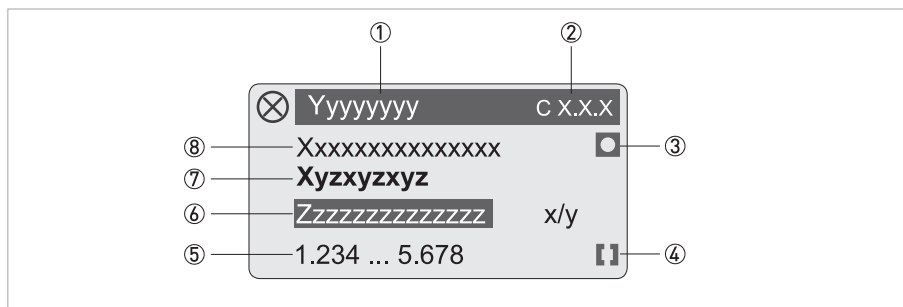

Figure 6-5: Display when setting parameters, 4 lines

- ① Current menu(s), submenu or function
- ② Number relating to ⑦
- ③ Denotes factory setting
- ④ Denotes permissible value range
- ⑤ Permissible value range for numeric values
- ⑥ Currently set value, unit or function (when selected, appears with white text, blue background)
This is where the data is changed.
- ⑦ Current parameter
- ⑧ Factory setting of parameter

6.1.3 Display when previewing parameters, 4 lines

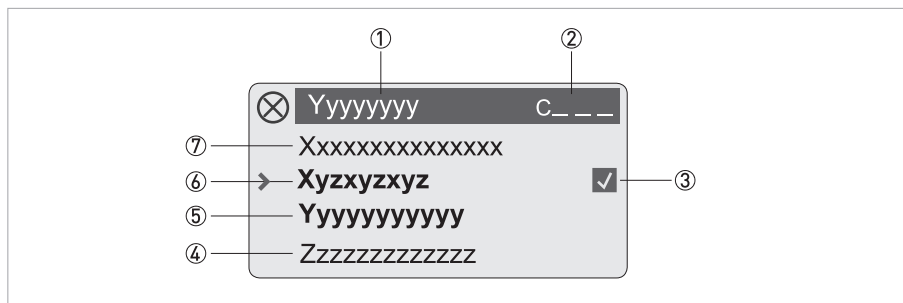

Figure 6-6: Display when previewing parameters, 4 lines

- ① Current menu(s), submenu or function
- ② Number relating to ⑥
- ③ Denotes a changed parameter (simple check of changed data when browsing through lists)
- ④ Next parameter
- ⑤ Currently set data from ⑥
- ⑥ Current parameter (for selection press key >; then see previous chapter)
- ⑦ Factory setting of parameter

6.2 Basic principles of operation

6.2.1 Functional description of the keys



INFORMATION!

- It is recommended to activate the push buttons perpendicular to the front. Touching them from the side can cause incorrect operation.
- The mechanical keys and keys for the bar magnet have the same functionality.

→	Switch from measuring mode to menu mode
	Switch to one menu level lower
	Open menu item and activate change mode
	In change mode: Move the input cursor one position to the right; after the last digit the input cursor jumps back to the beginning.
↑ or ↓	Change between the menu items within a menu level
	In measuring mode: Switch between 1. measurement page, 2. measurement page and status message.
	In change mode: Changing parameters and settings; running through the available characters; shifting the decimal point to the right or left.
↵	Confirm settings and changes
	Return to measuring mode

Table 6-2: Description of the operating keys

6.2.2 Switch from measuring mode to menu mode

Measuring mode	Operation	Menu mode
156.3 kg/h	→	> Quick Setup

Use the ↵ button to exit menu mode and return to measuring mode.

6.2.3 Change the settings in the menu

Press the → button to enter the menu.

Use the ↵ button to exit menu mode and return to measuring mode.



- Use the ↵ and ↑ or ↓ keys to navigate in the menu. The current values or settings are displayed. Save the new value or setting using the ↵ key.
- Some menu items contain several setting options. They are displayed in sequence by pressing the ↵ key.
- Press the ↵ button to save the settings, or to reject them.
- Before returning to measuring mode, you are prompted "Save Configuration?" which you need to accept with "Yes". Switch between "Yes", "Back" and "No" by pressing the ↑ or ↓ keys.

Save Configuration? Yes	←	Changes are accepted. An update is carried out and the display returns to measuring mode.
Save Configuration? No	←	Changes are discarded. The display returns to measuring mode.
Save Configuration? Back	←	Returns to menu mode

Example: Changing the default parameter from m³/h to l/h

Procedure	Display		Procedure	Display
	1.25 m ³ /h		8x ↑	Volume Flow L/h
2x →	A Quick Setup		4x ←	Save Configuration? Yes
8x ↓	A9 Units		1x ←	1250 L/h
2x →	Volume Flow m ³ /h			

6.2.4 Character selection in change mode

Depending on the menu function, the following characters are available:

Numbers

0	1	2	3	4	5	6	7	8	9
---	---	---	---	---	---	---	---	---	---

Lower case letters

a	b	c	d	e	f	g	h	i	j
k	l	m	n	o	p	q	r	s	t
u	v	w	x	y	z				

Upper case letters

A	B	C	D	E	F	G	H	I	J
K	L	M	N	O	P	Q	R	S	T
U	V	W	X	Y	Z				

Special characters

2	3	_	-	/	.				
---	---	---	---	---	---	--	--	--	--

6.2.5 Units, figures and factors

Numerical values and factors are displayed in a 8 digit format. Numerical values are either displayed in floating point format (12345678) or are expressed in exponential format (12.345e06). Exponents are used in following steps: 03 / 06 / 09 or -03 / -06 / -09 etc. The conversion factor of the totalizer and the pulse output, however, is expressed in whole numbers.

Basic units

Flow type	Basic units	Menu
Volume flow	m ³ /h	A9 and/or C6.5
Norm. volume flow	Nm ³ /h	A9 and/or C6.5
Mass flow	kg/h	A9 and/or C6.5

User defined units can be entered in menu "A9 or C6.5 Units". The unit (text) as well as the conversion factor (number) and offset can be entered here. The conversion factor must always be entered based on the basic unit.

Totalizer

The basic units for the totalizer are m³ for volume, Nm³ for standard volume and kg for mass. Volume flow, norm. volume flow and mass flow can be selected in menu "C4.1 Flow Totalizer". If counting is to be done in another flow unit, the unit must be changed in menu "C6.5 Units".

6.2.6 Security and permissions

Access levels

The vortex flowmeter features a multi-level security concept, which helps to prevent accidental or unauthorised configuration changes.

To gain a specific access level you need to log into the device by entering a four digit hexadecimal password associated with that access level (refer to menu "C6.2 Security"). You are able to change the passwords of "Operator" and "Expert" access levels if that particular level has been reached.

The "User" access level does not have a specific password – if you enter any password not assigned to a level, e.g. "0000" (which is an invalid password), you will fall back to "User" access level.

The table below lists the access levels, their default passwords and associated permissions.

Access level	Default password	Permissions
User	0000 (any unassigned password)	<ul style="list-style-type: none"> View device information Configure the display (C5), including changing the display language and the content of the measurement pages
Operator	0009	<ul style="list-style-type: none"> All rights of "User" access level Configure binary output (C2.2) Configure all HART[®] communication options (C3) with the exception of "C3.1.1 Current Loop Mode" Change "Operator" password (C6.2.2) – note that the new password must have three leading zeroes ("000") Activate a different meter type
Expert	0058	<ul style="list-style-type: none"> All configuration rights, especially process setup (C1) and current output (C2.1) Change "Expert" password (C6.2.2) – note that the new password must have two leading zeroes ("00")



INFORMATION!

When a particular access level has been enabled, please pay close attention to a "lock" symbol which might be present at the right side of a menu entry. This lock symbol indicates that your current access level allows you to read but not write this entry.



INFORMATION!

When entering the four digit password please be sure to type in all leading zeroes – i.e. enter the default "Operator" password as "0009" and not only "9" by skipping the remaining digits.



INFORMATION!

After a cold start of the device the user role will always be reset to "User".

Reset passwords

In case the user has changed particular passwords from their default settings and is not able to log in anymore, there is a "Reset Passwords" command available in the C6.2.3 submenu.

However to prevent unauthorised use this command itself is protected by a non-changeable unique password available by contacting the manufacturer.

6.3 Overview of the most important functions and units



INFORMATION!

A complete list of all functions and short descriptions is provided in the next section. All default parameters and settings are adapted for the customer.

Menu structure

- "A Quick Setup": Quick check and setup of the signal converter, including application assistants
- "B Test": Simulation functions and display of the actual measurement values for all variables
- "C Setup": Complete setup possibilities

Frequently used functions

Menu	Explanation
A1 Language or C5.1 Language	Select the menu language (for details refer to following chapter)
B1.2 Current Output	Check the current output
B1.3.1 Pulse Output	Check the pulse output
B1.3.2 Frequency Output	Check the frequency output
B1.3.3 Status/Limit Output	Check the status output
C1.8 Time Constant	Time constant, damping value
C2.1.2 0% Range	Minimum flow rate (current output) The set value represents the 4 mA value of the current output. Usually 0% of flow is set as 4 mA, but it is also possible to assign higher flow values to 4 mA.
C2.1.3 100% Range	Maximum flow rate (current output) The set value represents the 20 mA value of the current output. Usually 100% of flow is set as 20 mA, but it is also possible to assign lower flow values to 20 mA.

Table 6-3: Most important functions

6.4 Menu languages

Language selection

English	German	French	Italian	Spanish
Swedish	Danish	Czech	Polish	Russian
Chinese				
In preparation:				
Dutch	Portuguese	Finnish	Slovenian	Turkish
Hungarian	Norwegian	Estonian	Latvian	Lithuanian
Moldavian	Slovak	Albanian	Bulgarian	Romanian

Table 6-4: Menu languages

6.5 Gas options for gas measurement

Gases can be selected in menu "A8, C1.2 Medium" or "C1.3.1 Gas Mixture".

For fluid selection gas, wet gas or gas mixture the following gas selection is available:

Air	Ammonia	Argon	i-Butane	n-Butane	
CO	CO ₂	Ethane	Ethylene	n-Hexane	
Hydrogen	Hydrogen Sulfide	Methane	Neon	Nitrogen	
Oxygen	i-Pentane	n-Pentane	Propane	Xenon	

Gas mixtures can be defined as percentage shares of the above mentioned gases.

Default format for the shares is 0.00000 %.

To enter shares > 9.99999 % the point can be shifted rightwards by moving the cursor to the point and then press the upwards button ↑.

Change between the digits by pressing the rightwards button →.

After reaching the last digit the cursor will jump again to the first digit.

6.6 Units

The following units can be selected and set in menu A9 and/or C6.5. Furthermore, for each measurement customised units can be defined.

Units for volume flow

Liquids, steam, gases			
/d	/h	/min	/s
m ³	m ³	m ³	m ³
ml	ml	ml	ml
L	L	L	L
ML	ML	-	-
hl	hl	hl	hl
ft ³	ft ³	ft ³	ft ³
gal	gal	gal	gal
kgal	kgal	kgal	kgal
Mgal	Mgal	-	-
ImpGal	ImpGal	ImpGal	ImpGal
MImpGal	MImpGal	-	-
bbbl	bbbl	bbbl	bbbl
acft	acft	acft	acft
fl.oz[Imp]	fl.oz[Imp]	fl.oz[Imp]	fl.oz[Imp]
fl.oz[US]	fl.oz[US]	fl.oz[US]	fl.oz[US]
Customised volume flow			

Table 6-5: Flow measurements and their units

Units for norm./standard* volume flow

Liquids, steam, gases			
/d	/h	/min	/s
Nm ³	Nm ³	Nm ³	Nm ³
NL	NL	NL	NL
Sm ³	Sm ³	Sm ³	Sm ³
SL	SL	SL	SL
Sft ³	Sft ³	Sft ³	Sft ³
Customised norm./standard volume flow			

Table 6-6: Flow measurements and their units

* The units Nx/x and Sx/x shall be considered as equivalent. They serve as an indication for a normalised or standardised measuring variable and do not identify the underlying reference system.

Units for mass flow

/d	/h	/min	/s
kg	kg	kg	kg
-	g	g	g
t	t	t	-
lb	lb	lb	lb
Customised mass flow			

Table 6-7: Flow measurements and their units

Totalizer units

Volume	Norm./standard* volume	Mass
m ³	Nm ³	g
L	SL	kg
hl	SM ³	oz
in ³	Sft ³	lb
ft ³	NL	T
gal		
ImpGal		
bbl		
Customised volume		

Table 6-8: Totalizer units

* The units Nx and Sx shall be considered as equivalent. They serve as an indication for a normalised or standardised measuring variable and do not identify the underlying reference system.

Units additional measurements

Temperature	Pressure	Power	Energy	Density
°C	mbar	W	J	kg/m ³
°F	bar	kW	kJ	kg/L
K	atm	kJ/h	MJ	g/cm ³
°Rank	kg/m ²	MJ/s	kW*h	g/L
Customised temperature	kg/cm ²	MJ/h	Mcal	g/ml
	g/cm ²	Mcal/h	BTU	lb/gal
	torr	Btu/h	Customised energy	lb/ft ³
	psi	Mbtu/s		lb/in ³
	psi (abs)	Mbtu/h		Customised density
	b/ft ²	Mbtu/d		
	MPa	Customised power		
	kPa			
	Pa			
	Customised pressure			

Table 6-9: Units additional measurements

The pressure unit psi (abs) refers to a reference point of 0 bara / 0 psia.
 All other pressure units are gauge pressure units and refer to a reference pressure of 1.01325 bara / 14.7 psia (acc. to DIN 1343).

6.7 Menu structure

6.7.1 Menu overview "A Quick Setup"

Meas.	Menu A		Submenus		
> ←	↓ ↑	> ←	↓ ↑	> ←	↓ ↑
	A Quick Setup		A1 Language		
			A2 Contrast		
			A3 Login		
			A4 Tag		
			A5 Long Tag		
			A6 Message View		
			A7 Fluid		
			A8 Medium		
			A9 Units	A9.1 Volume Flow	A9.2 Cst. Vol. Flow
				A9.3 Norm. Vol. Flow	A9.4 Cst. N.Vol.Flow
				A9.5 Mass Flow	A9.6 Cst. Mass Flow
				A9.7 Power	A9.8 Cst. Power
				A9.9 Volume	A9.10 Cst. Volume
				A9.11 Norm. Volume	A9.12 Cst. Norm. Volume
				A9.13 Mass	A9.14 Cst. Mass
				A9.15 Energy	A9.16 Cst. Energy
				A9.17 Pressure	A9.18 Cst. Pressure
				A9.19 Temperature	A9.20 Cst. Temp.
				A9.21 Density	A9.22 Cst. Density
			A10 Meter Type		
			A11 Application Assistant	A11.1 Liquids	
				A11.2 Saturated Steam	
				A11.3 Superheated Steam	
				A11.4 Heat Measurement	
				A11.5 Gas	
				A11.6 FAD	
			A12 Cluster Checks	Cluster 1...12	

6.7.2 Menu overview "B Test"

Meas.	Menu B		Submenus				
> ←	↓ ↑	> ←	↓ ↑	> ←	↓ ↑	> ←	↓ ↑ >
	B Test		B1 Simulation		B1.1 Set Value		B1.1.1 Volume Flow
							B1.1.2 Norm. Volume Flow
							B1.1.3 Mass Flow
							B1.1.4 Gross Power
							B1.1.5 Net Power
							B1.1.6 FAD
							B1.1.7 Volume
							B1.1.8 Norm. Volume
							B1.1.9 Mass
							B1.1.10 Gross Energy
							B1.1.11 Net Energy
							B1.1.12 Density
							B1.1.13 Temperature1
							B1.1.14 Temperature2
							B1.1.15 Pressure
							B1.1.16 Vortex Frequency
							B1.1.17 Velocity
							B1.1.18 Specific Enthalpy
							B1.1.19 Specific Heat Cap.
							B1.1.20 Reynolds Number
					B1.2 Current Output		
					B1.3 Binary Output		B1.3.1 Pulse Output
							B1.3.2 Frequency Output
							B1.3.3 Status/Limit Output
	B Test		B2 Actual Values		B2.1 Operating Time		
					B2.2 Volume Flow		
					B2.3 Norm. Volume Flow		
					B2.4 Mass Flow		
					B2.5 Gross Power		
					B2.6 Net Power		
					B2.7 FAD		
					B2.8 Volume		
					B2.9 Norm. Volume		
					B2.10 Mass		
					B2.11 Gross Energy		
					B2.12 Net Energy		
					B2.13 Density		
					B2.14 Temperature1		
					B2.15 Temperature2		

Meas.	Menu B		Submenus				
> ←	↓ ↑	> ←	↓ ↑	> ←	↓ ↑	> ←	↓ ↑ >
	B Test		B2 Actual Values		B2.16 Pressure		
					B2.17 Vortex Frequency		
					B2.18 Velocity		
					B2.19 Specific Enthalpy		
					B2.20 Specific Heat Cap.		
					B2.21 Reynolds Number		

6.7.3 Menu overview "C Setup"

Meas.	Menu C		Submenus				
> ←	↓ ↑	> ←	↓ ↑	> ←	↓ ↑	> ←	↓ ↑ >
	C Setup		C1 Process		C1.1 Fluid		
					C1.2 Medium		
					C1.3 Gas		C1.3.1 Gas Mixture
							C1.3.2 Relative Humidity
							C1.3.3 Inlet Temperature
							C1.3.4 Atm. Pressure
							C1.3.5 Filter Pressure Drop
							C1.3.6 Inlet Rel. Humidity
							C1.3.7 Outlet Rel. Humidity
							C1.3.8 Compressor RPM
							C1.3.9 Rated Compr. RPM
					C1.4 Saturated Steam		C1.4.1 Dry Factor
					C1.5 Current Input		C1.5.1 Function
							C1.5.2 Current Input Meas.
							C1.5.3 0% Range / 4mA
							C1.5.4 100% Range / 20mA
					C1.6 Temp. Sensor		C1.6.1 Temp. Source1
							C1.6.2 Temp. Source2
					C1.7 Pressure Sensor		C1.7.1 Pressure Source
					C1.8 Time Constant		
					C1.9 Low Flow Cutoff		
					C1.10 Operating Values		C1.10.1 Oper. Temperature
							C1.10.2 Oper. Pressure
							C1.10.3 Oper. Density
							C1.10.4 Min/Max Oper. Dens.

Meas.	Menu C	Submenus					
> ←	↓ ↑	> ←	↓ ↑	> ←	↓ ↑	> ←	↓ ↑ >
	C Setup	C1 Process			C1.11 Normal Values		C1.11.1 Norm. Temperature
C1.11.2 Norm. Pressure							
C1.11.3 Norm. Density							
C2 Output					C2.1 Current Output		C2.1.1 Current Out. Meas.
							C2.1.2 0% Range
							C2.1.3 100% Range
		C2.1.4 Lower Ext. Range					
		C2.1.5 Upper Ext. Range					
		C2.1.6 Error Function					
		C2.1.7 Low Error Current					
		C2.1.8 High Error Current					
		C2.1.9 Trimming					
		C2.2 Binary Output		C2.2.1 Function			
				C2.2.2 Pulse Output			
				C2.2.3 Frequency Output			
C2.2.4 Status Output							
C2.2.5 Limit Switch							
C2.2.6 Invert Signal							
C3 Communication		C3.1 HART		C3.1.1 Current Loop Mode			
				C3.1.2 Identification			
				C3.1.3 Device Information			
				C3.1.4 HART Variables			
				C3.1.5 Catch DV Temp.			
				C3.1.6 Catch DV Pressure			
C4 Totalizer	C4.1 Flow Totalizer		C4.1.1 Measurement				
			C4.1.2 Preset Value				
			C4.1.3 Reset Totalizer?				
			C4.1.4 Set Start Value				
			C4.1.5 Start Totalizer?				
			C4.1.6 Stop Totalizer?				
			C4.1.7 Information				
	C4.2 Energy Totalizer		C4.2.1 Measurement				
			C4.2.2 Preset Value				
			C4.2.3 Reset Totalizer?				
			C4.2.4 Set Start Value				
			C4.2.5 Start Totalizer?				
C4.2.6 Stop Totalizer?							
C4.2.7 Information							

Meas.	Menu C	Submenus				
> ⏪	↓ ↑	> ⏪	↓ ↑	> ⏪	↓ ↑	> ⏪
	C Setup		C5 Display		C5.1 Language	
					C5.2 Contrast	
					C5.3 1. Meas. Page	C5.3.1 Function
						C5.3.2 Measurement 1. Line
						C5.3.3 0% Range
						C5.3.4 100% Range
						C5.3.5 Format 1. Line
						C5.3.6 Measurement 2. Line
						C5.3.7 Format 2. Line
						C5.3.8 Measurement 3. Line
						C5.3.9 Format 3. Line
					C5.4 2. Meas. Page	C5.4.1 Function
						C5.4.2 Measurement 1. Line
						C5.4.3 0% Range
						C5.4.4 100% Range
						C5.4.5 Format 1. Line
						C5.4.6 Measurement 2. Line
						C5.4.7 Format 2. Line
						C5.4.8 Measurement 3. Line
						C5.4.9 Format 3. Line
			C6 Device		C6.1 Information	C6.1.1 Tag
						C6.1.2 Long Tag
						C6.1.3 Meter Type
						C6.1.4 Serial Number
						C6.1.5 Manufacturer ID
						C6.1.6 Device Name
						C6.1.7 V Number
						C6.1.8 Electronic Revision
						C6.1.9 Device Revision
						C6.1.10 Software Revision
						C6.1.11 Hardware Revision
						C6.1.12 Electronic Serial No.
						C6.1.13 CG Number
						C6.1.14 Production Date
						C6.1.15 Calibration Date
					C6.2 Security	C6.2.1 Login
						C6.2.2 Change Password
						C6.2.3 Reset Passwords
						C6.2.4 Unlock SIL

Meas.	Menu C		Submenus				
> ⏪	↓ ↑	> ⏪	↓ ↑	> ⏪	↓ ↑	> ⏪	↓ ↑ >
	C Setup		C6 Device		C6.3 Extras		C6.3.1 Meter Type
							C6.3.2 Heat
							C6.3.3 Heat & Dens. by Pres.
							C6.3.4 Heat & Dens. & FAD
					C6.4 Error		C6.4.1 Message View
							C6.4.4 Error Mapping
							C6.4.4.1 Totalizer
					C6.5 Units		C6.5.1 Volume Flow ①
							C6.5.3 Norm. Vol. Flow
							C6.5.5 Mass Flow
							C6.5.7 Power
							C6.5.9 Volume
							C6.5.11 Norm. Volume
							C6.5.13 Mass
							C6.5.15 Energy
							C6.5.17 Pressure
							C6.5.19 Temperature
							C6.5.21 Density
					C6.6 Factory Default		C6.6.1 Reset to Fact. Def.?
					C6.8 Proof Test		C6.8.2 Run Proof Test?

① In all even numbered menus C6.5.2 to .22 Cst. Units (Custom Units) there is a submenu with the prompt for "Text", "Offset" and "Factor".

6.7.4 Menu description "A Quick Setup"

Function	Setting / Description
A1 Language	Available display languages: German, English, French, Italian, Spanish, Russian, Chinese, Swedish, Danish, Czech, Polish; 15 further languages in preparation (for details refer to <i>Menu languages</i> on page 56)
A2 Contrast	Adjust contrast of local display (-10...+10; Standard = 0)
A3 Login	Enter password: 0000 (to change password refer to menu C6.2.2)
A4 Tag	Entry and display of measuring point identifier (8 digits).
A5 Long Tag	Entry and display of long measuring point identifier (1...32 digits). Entry will be displayed in the header bar on the LC display (depending on letter size, min. 11 digits can be displayed).
A6 Message View	NAMUR messages (F, S, M, C, I) For further information refer to <i>Status messages and diagnostic information</i> on page 87.
A7 Fluid	Select: Liquid / Steam / Gas / Wet Gas / Gas Mixture Depending on selected fluid, appropriate medium can be selected in A8
A8 Medium	If fluid is "Gas" or "Wet Gas" (for details refer to <i>Gas options for gas measurement</i> on page 57)
	The following selection is available for fluid = "Steam": Saturated Steam / Superheated Steam / Custom
	The following selection is available for fluid = "Liquid": Water / Custom
	The following selection is available for fluid = "Wet Gas": Here, a gas can be selected as a wet gas from all of the above mentioned gases.
A9 Units	For further information refer to menu C6.5.
A10 Meter Type	Standard: For liquids, gases and steam; integrated temperature compensation for saturated steam.
	Heat: For liquids, gases and steam; integrated temperature compensation for saturated steam, gross/net heat measurement for saturated steam and water.
	Heat & Dens. by Pres.: Integrated density compensation for saturated steam, superheated steam and gas, gross/net heat measurement for saturated steam, superheated steam and water.
	Heat & Dens. & FAD: Integrated density compensation for saturated steam, superheated steam and gas, gross/net heat measurement for saturated steam, superheated steam and water, FAD functionality.
A11 Application Assistant	For details refer to next tables.
A12 Cluster Checks	For further information refer to <i>A12 plausibility checks</i> on page 93.

A11 Application Assistant

The factory settings of the vortex flowmeter have been made in accordance with the order specifications. Nonetheless it can be necessary to make additional settings for the use of some functionalities. For an easy operation the device is equipped with an application assistant for each type of application. The application assistant guides the operator through the configuration of the flowmeter.

The application assistant starts with the definition of all basic units. Afterwards, the functionality-specific parameters have to be set. Settings such as configurations of the outputs or the totaliser functions, can require submenus. These can be entered by pressing the arrow "→" key. In case they are not needed, the menu items can be skipped by pressing the enter "↵" key.

To perform the settings for the application assistant, the operator must be logged on the access level "Expert". For further information refer to *Security and permissions* on page 54.

To abort an application assistant sequence, press "→" and "↑" at the same time. Be sure to select "Save Config.? No" when returning to measuring mode.

Please select a suitable application assistant from the following options:	
A11.1 Liquids	Configuration for liquid applications, incl. the correspondent output and totalizer.
A11.2 Saturated Steam	Configuration for saturated steam applications and density compensation by external or internal temperature transmitter.
A11.3 Superheated Steam	Configuration of superheated steam applications and definition of temperature and pressure value sources.
A11.4 Heat Measurement	Configuration of gross and net heat applications and definition of temperature and/or pressure value sources.
A11.5 Gas	Configuration of gas applications with optionally internal or external pressure and temperature sources for the density compensation.
A11.6 FAD	Configuration of FAD (Free Air Delivery) applications for compressors.

A11.1 Application Assistant - Liquid

Function	Setting / Description
.1	
.2 Units	
.2.1 Volume Flow	Select unit (default: according to order specification or m ³ /h).
.2.2 Mass Flow	Select unit (default: according to order specification or kg/h).
.2.3 Volume	Select unit (default: according to order specification or m ³).
.2.4 Mass	Select unit (default: according to order specification or kg).
.2.5 Temperature	Select unit (default: according to order specification or °C).
.2.6 Pressure	Select unit (default: according to order specification or bar).
.2.7 Density	Select unit (default: according to order specification or kg/m ³).
.3 Process	Process configuration.
.3.1 Fluid	Select "Liquid".
.3.2 Medium	Select "Water" or "Custom".
.3.3 Time Constant	0...100 s
.3.4 Low Flow Cutoff	Enter low flow cutoff point in current volume flow unit.
.4 Operating Values	Current process conditions in case they are not measured nor calculated.
.4.1 Oper. Temperature	Input in selected unit.
.4.2 Oper. Pressure	Input in selected unit.
.4.3 Oper. Density	Input in selected unit.
.5 Current Output	Current output configuration.
.5.1 Current Out. Meas.	Select measurement variable for current output.
.5.2 0% Range	The set value represents 4 mA at the current output. Usually 0% flow = 4 mA, but it is also possible to define a higher flow value for 4 mA.
.5.3 100% Range	The set value represents 20 mA at the current output. Usually 100% flow = 20 mA, but it is also possible to define a lower flow value for 20 mA.
.5.4 Error Function	Low / Off / High / Hold
.5.5 Low Error Current	3.5...3.6 mA, available if "Error Function = Low"
.5.6 High Error Current	21...21.5 mA, available if "Error Function = High"
.6 Binary Output	Optionally configure the binary output.
.6.1 Function	Select the binary output function: Limit Switch / Status / Frequency / Pulse / Off
.6.2 Invert Signal	On, Off
.7 Pulse Output	This menu is available if "Binary Output Function = Pulse".
.8 Frequency Output	This menu is available if "Binary Output Function = Frequency".
.9 Status Output	This menu is available if "Binary Output Function = Status".
.10 Limit Switch	This menu is available if "Binary Output Function = Limit Switch".
.11 Flow Totalizer	Optionally configure the flow totalizer.
.12 Energy Totalizer	This menu is available if a non-standard meter type has been configured (refer to "C6.3 Extras").
.13 1. Meas. Page	One Value / Two Values / Three Values / One Value & Bargraph / Two values & Bargraph
.14 2. Meas. Page	One Value / Two Values / Three Values / One Value & Bargraph / Two values & Bargraph

A11.2 Application Assistant - Saturated Steam

Function	Setting / Description
.1	
.2 Units	Same options as in A11.1.2.
.3 Process	
.3.1 Fluid	Select "Steam".
.3.2 Medium	Select "Saturated Steam".
.3.3 Time Constant	0...100 s
.3.4 Low Flow Cutoff	Enter low flow cutoff point in current volume flow unit.
.4 Current Input	
.4.1 Function	Select "On" if applicable.
.4.2 Current Input Meas.	Select "Temperature External" if "Function = On".
.5.1 Temp. Source1	Internal / External / External HART / Not Available
.5.2 Temp. Source2	Internal / External / External HART / Not Available Temperature source 1 and 2 must be different.
.6 Operating Values	Same options as in A11.1.4.
.7 Current Output	Same options as in A11.1.5.
.8 Binary Output	Same options as in A11.1.6.
.9 Pulse Output	Same options as in A11.1.7.
.10 Frequency Output	Same options as in A11.1.8.
.11 Status Output	Same options as in A11.1.9.
.12 Limit Switch	Same options as in A11.1.10.
.13 Flow Totalizer	Same options as in A11.1.11.
.14 Energy Totalizer	Same options as in A11.1.12.
.15 1. Meas. Page	Same options as in A11.1.13.
.16 2. Meas. Page	Same options as in A11.1.14.

A11.3 Application Assistant - Superheated Steam

Function	Setting / Description
This application assistant is available if meter type is set to "Heat & Dens. by Pres." or "Heat & Dens. & FAD" (refer to "C6.3 Extras").	
.1	
.2 Units	Same options as in A11.1.2.
.3 Process	
.3.1 Fluid	Select "Steam".
.3.2 Medium	Select "Superheated Steam".
.3.3 Time Constant	0...100 s
.3.4 Low Flow Cutoff	Enter low flow cutoff point in current volume flow unit.
.4 Current Input	
.4.1 Function	Select "On", if applicable.
.4.2 Current Input Meas.	Select "Temperature External" or "Pressure External".
.5.1 Temp. Source1	Internal / External / External HART / Not Available
.5.2 Temp. Source2	Internal / External / External HART / Not Available Temperature source 1 and 2 must be different.
.6 Operating Values	Same options as in A11.1.4.
.7 Current Output	Same options as in A11.1.5.
.8 Binary Output	Same options as in A11.1.6.
.9 Pulse Output	Same options as in A11.1.7.
.10 Frequency Output	Same options as in A11.1.8.
.11 Status Output	Same options as in A11.1.9.
.12 Limit Switch	Same options as in A11.1.10.
.13 Flow Totalizer	Same options as in A11.1.11.
.14 Energy Totalizer	Same options as in A11.1.12.
.15 1. Meas. Page	Same options as in A11.1.13.
.16 2. Meas. Page	Same options as in A11.1.14.

A11.4 Application Assistant - Heat Measurement

Function	Setting / Description
This application assistant is available if meter type is not set to "Standard" (refer to "C6.3 Extras").	
.1	
.2 Units	
.2.1 Volume Flow	Select unit (default: according to order specification or m ³ /h).
.2.2 Mass Flow	Select unit (default: according to order specification or kg/h).
.2.3 Power	Select unit (default: according to order specification or kJ/h).
.2.4 Volume	Select unit (default: according to order specification or m ³).
.2.5 Mass	Select unit (default: according to order specification or kg).
.2.6 Energy	Select unit (default: according to order specification or kJ).
.2.7 Temperature	Select unit (default: according to order specification or °C).
.2.8 Pressure	Select unit (default: according to order specification or bar).
.2.9 Density	Select unit (default: according to order specification or kg/m ³).
.3 Process	
.3.1 Fluid	Select "Steam" or "Liquid".
.3.2 Medium	Select "Saturated Steam", "Superheated Steam" or "Water".
.3.3 Time Constant	0...100 s
.3.4 Low Flow Cutoff	Enter low flow cutoff point in current volume flow unit.
.4 Current Input	
.4.1 Function	Select "On".
.4.2 Current Input Meas.	Select "Temperature External".
.5 Temp. Sensor	
.5.1 Temp. Source1	Internal / External / External HART / Not Available
.5.2 Temp. Source2	Internal / External / External HART / Not Available Temperature source 1 and 2 must be different.
.6 Operating Values	Same options as in A11.1.4.
.7 Current Output	
.7.1 Current Out. Meas.	Select "Gross Power" or "Net Power".
.7.2 0% Range	The set value represents 4 mA at the current output. Usually 0% flow = 4 mA, but it is also possible to define a higher flow value for 4 mA.
.7.3 100% Range	The set value represents 20 mA at the current output. Usually 100% flow = 20 mA, but it is also possible to define a lower flow value for 20 mA.
.7.4 Error Function	Same options as in A11.1.5.4.
.7.5 Low Error Current	3.5...3.6 mA
.7.6 High Error Current	21...21.5 mA
.8 Binary Output	Same options as in A11.1.6.
.9 Pulse Output	Same options as in A11.1.7.
.10 Frequency Output	Same options as in A11.1.8.
.11 Status Output	Same options as in A11.1.9.
.12 Limit Switch	Same options as in A11.1.10.
.13 Flow Totalizer	Same options as in A11.1.11.
.14 Energy Totalizer	Same options as in A11.1.12.

Function	Setting / Description
.15 1. Meas. Page	Same options as in A11.1.13.
.16 2. Meas. Page	Same options as in A11.1.14.

A11.5 Application Assistant - Gas

Function	Setting / Description
.1	
.2 Units	Same options as in A11.1.2.
.2.1 Volume Flow	Select unit (default: according to order specification or m ³ /h).
.2.2 Norm. Vol. Flow	Select unit (default: according to order specification or Nm ³ /h).
.2.3 Mass Flow	Select unit (default: according to order specification or kg/h).
.2.4 Volume	Select unit (default: according to order specification or m ³).
.2.5 Norm. Volume	Select unit (default: according to order specification or Nm ³).
.2.6 Mass	Select unit (default: according to order specification or kg).
.2.7 Temperature	Select unit (default: according to order specification or °C).
.2.8 Pressure	Select unit (default: according to order specification or bar).
.2.9 Density	Select unit (default: according to order specification or kg/m ³).
.3 Process	
.3.1 Fluid	Select: "Gas", "Wet Gas" or "Gas Mixture".
.3.2 Medium	If fluid is "Gas" or "Wet Gas" (for details refer to <i>Gas options for gas measurement</i> on page 57).
.3.3 Time Constant	0...100 s
.3.4 Low Flow Cutoff	Enter low flow cutoff point in current volume flow unit.
.4 Current Input	Same options as in A11.3.4.
.5.1 Temp. Source1	Internal / External / External HART / Not Available
.5.2 Temp. Source2	Internal / External / External HART / Not Available Temperature source 1 and 2 must be different.
.6 Gas Mixture	If fluid = "Gas Mixture", enter gas mixture in %.
.7 Gas	
.7.1 Relative Humidity	If fluid = "Wet Gas", enter 0...100%.
.8 Operating Values	Same options as in A11.1.4.
.9 Normal Values	Default settings according to order specification or DIN.
.9.1 Norm. Temperature	Confirm default setting or define in selected temperature unit.
.9.2 Norm. Pressure	Confirm default setting or define in selected pressure unit.
.9.3 Norm. Density	Confirm default setting or define in selected density unit.
.10 Current Output	Same options as in A11.1.5.
.11 Binary Output	Same options as in A11.1.6.
.12 Pulse Output	Same options as in A11.1.7.
.13 Frequency Output	Same options as in A11.1.8.
.14 Status Output	Same options as in A11.1.9.
.15 Limit Switch	Same options as in A11.1.10.
.16 Flow Totalizer	Same options as in A11.1.11.

Function	Setting / Description
.17 1. Meas. Page	Same options as in A11.1.13.
.18 2. Meas. Page	Same options as in A11.1.14.

A11.6 Application Assistant - FAD

Function	Setting / Description
This application assistant is available if meter type is set to "Heat & Dens. & FAD" (refer to "C6.3 Extras").	
.1	
.2 Units	
.2.1 Volume Flow	Select unit (default: according to order specification or m ³ /h).
.2.2 Norm. Vol. Flow	Select unit (default: according to order specification or Nm ³ /h).
.2.3 Volume	Select unit (default: according to order specification or m ³).
.2.4 Norm. Volume	Select unit (default: according to order specification or Nm ³).
.2.5 Temperature	Select unit (default: according to order specification or °C).
.2.6 Pressure	Select unit (default: according to order specification or bar).
.2.7 Density	Select unit (default: according to order specification or kg/m ³).
.3 Process	
.3.1 Fluid	Select "Gas".
.3.2 Medium	Select "Air".
.3.3 Time Constant	0...100 s
.3.4 Low Flow Cutoff	Enter low flow cutoff point in current volume flow unit.
.4 Current Input	
Same options as in A11.3.4.	
.5.1 Temp. Source1	Internal / External / External HART / Not Available
.5.2 Temp. Source2	Internal / External / External HART / Not Available Temperature source 1 and 2 must be different.
.6 Gas	
.6.1 Inlet Temperature	Enter temperature on inlet side in selected unit.
.6.2 Atm. Pressure	Enter current ambient pressure in selected unit.
.6.3 Filter Pressure Drop	Enter filter pressure drop in selected unit.
.6.4 Inlet Rel. Humidity	Enter air humidity on inlet side in 0...100%.
.6.5 Outlet Rel. Humidity	Enter air humidity on outlet side in 0...100%.
.6.6 Compressor RPM	Compressor revolutions per minute.
.6.7 Rated Compr. RPM	Rated compressor revolutions per minute.
.7 Operating Values	
Same options as in A11.1.4.	
.8 Current Output	
Select "FAD".	
.9 Binary Output	
Same options as in A11.1.6.	
.10 Pulse Output	
Same options as in A11.1.7.	
.11 Frequency Output	
Same options as in A11.1.8.	
.12 Status Output	
Same options as in A11.1.9.	
.13 Limit Switch	
Same options as in A11.1.10.	
.14 Flow Totalizer	
Same options as in A11.1.11.	
.16 1. Meas. Page	
Same options as in A11.1.13.	
.17 2. Meas. Page	
Same options as in A11.1.14.	

6.7.5 Menu description "B Test"

For simulation and actual values refer to *Menu overview "B Test"* on page 62.

6.7.6 Menu description "C Setup"

For further information refer to *Menu overview "C Setup"* on page 63.

There are four different meter types (software versions) available for the signal converter:

Meter type	Description
Standard	Uncompensated measurement for liquids, gases and steam; integrated temperature compensation included for saturated steam
Heat	Same as "Standard", plus gross/net heat measurement for saturated steam and hot water
Heat & Dens. by Pres.	Same as "Heat", plus gross/net heat measurement for superheated steam; density compensation for the measurement of gas
Heat & Dens. & FAD	Same as "Heat & Dens. by Pres.", plus FAD (Free Air Delivery) measurement

Depending on the ordered meter type those options may have been ordered and are already activated or can be activated in menu "C6.3 Extras". For this purpose an activation password is necessary. Please contact the manufacturer.

When using the standard device all menu entries concerning heat measurement, density calculation and FAD are hidden.

Function	Setting / Description
C1 Process	
C1.1 Fluid	Select: Liquid / Steam / Gas / Wet Gas / Gas Mixture Appropriate media can be selected in menu C1.2 dependent on selected fluid type.
C1.2 Medium	If fluid = "Liquid": Water / Custom
	If fluid = "Steam": Saturated Steam / Superheated Steam / Custom
	If fluid is "Gas" or "Wet Gas" (for details refer to <i>Gas options for gas measurement</i> on page 57)
C1.3 Gas	This menu is available if fluid = "Wet Gas" or "Gas Mixture", or if medium = "Air". Here the gas composition or gas properties can be defined.
C1.3.1 Gas Mixture	This menu is available for fluid = "Gas Mixture". Enter gas mixture as percentage share of gas options (for details refer to <i>Gas options for gas measurement</i> on page 57)
C1.3.2 Relative Humidity	This menu is available if fluid = "Wet Gas". Enter: 0...100%
C1.3.3 Inlet Temperature	The menus C1.3.3 to C1.3.9 are part of the FAD functionalities. They are available, if fluid = "Gas", medium = "Air" and FAD functionality is included in the meter type option. Enter ambient temperature of the compressor inlet side in selected temperature unit (C6.5.19).
C1.3.4 Atm. Pressure	Enter ambient pressure of the compressor inlet side as value in selected pressure unit (C6.5.17).
C1.3.5 Filter Pressure Drop	Enter pressure drop of compressor filter in selected pressure unit (C6.5.17).
C1.3.6 Inlet Rel. Humidity	Enter relative air humidity of the compressor inlet side as 0...100%.
C1.3.7 Outlet Rel. Humidity	Enter relative air humidity of the compressor outlet side as 0...100%.

Function	Setting / Description
C1 Process	
C1.3.8 Compressor RPM	Enter compressor revolutions per minute.
C1.3.9 Rated Compr. RPM	Enter rated compressor revolutions per minute.
C1.4 Saturated Steam	This menu is available, if fluid = "Steam" and medium = "Saturated Steam".
C1.4.1 Dry Factor	Enter 0.85...1
C1.5 Current Input	The current input is a passive 2-wire 4...20 mA input. An external power supply is required (for details refer to <i>Current input</i> on page 40).
C1.5.1 Function	Select "On" or "Off" to enable or disable the current input.
C1.5.2 Current Input Meas.	If current input function (C1.5.1) = "On", the following selection is available: Pressure External / Temperature External
C1.5.3 0% Range / 4mA	0% value = 4 mA for pressure value or temperature value
C1.5.4 100% Range / 20mA	100% value = 20 mA for pressure value or temperature value
C1.6 Temp. Sensor	
C1.6.1 Temp. Source1	Select: Not available / Internal / External / External HART / Sat. Steam Temp. (Saturated steam temperature only available for meter types "Heat & Dens. by Pres." and "Heat & Dens. & FAD") Temperature source 1 and 2 must be different. If the current input is set to "Temperature External", either "Temp. Source1" or "Temp. Source2" may be set to "External". If the current input is set "Pressure External", the "External" option is not available to both temperature source 1 and 2.
C1.6.2 Temp. Source2	
C1.7 Pressure Sensor	
C1.7.1 Pressure Source	Select: Not Available / Internal / External / External HART (Pressure sensor support only available for meter types "Heat & Dens. by Pres." and "Heat & Dens. & FAD")
C1.8 Time Constant	Enter: 0...100 s
C1.9 Low Flow Cutoff	Sets low flow values to "0". Enter value for low flow cutoff in volumetric flow unit.
C1.10 Operating Values	Operating values are pre-set according to the application data; value can be adjusted subsequently, if required.
C1.10.1 Oper. Temperature	Enter value in selected temperature unit.
C1.10.2 Oper. Pressure	Enter value in selected pressure unit.
C1.10.3 Oper. Density	Enter value in selected density unit.
C1.10.4 Min/Max Oper. Dens.	Minimum and maximum operating densities are defined by the nominal diameter and the operating density as standard. By activating this function, deviating values for the minimum and maximum operating densities can be defined.
C1.10.4.1 Function	Select: On / Off If function = "On", min./max. operating density can be defined in C1.10.4.2 and C1.10.4.3
C1.10.4.2 Min. Oper. Density	Enter value for minimum operating density in selected density unit.
C1.10.4.3 Max. Oper. Density	Enter value for maximum operating density in selected density unit.
C1.11 Normal Values	Standard system values are pre-set according to the application data, if applicable. Standard system can be changed by changing values in C1.11.1 to C1.11.3.
C1.11.1 Norm. Temperature	Enter value in selected temperature unit.
C1.11.2 Norm. Pressure	Enter value in selected pressure unit.

Function	Setting / Description
C1 Process	
C1.11.3 Norm. Density	Enter value in selected density unit.
C1.12 Heater/Cooler	In net heat measurement applications this functionality monitors "Temp. Source 1" (C1.6.1) and "Temp. Source 2" (C1.6.2) and triggers a NE 107 status message type C in case of temperature incongruity. Select: - Heater: status message is triggered in case of "Temp. Source 1" < "Temp. Source 2" - Cooler: status message is triggered in case of "Temp. Source 1" > "Temp. Source 2" - Don't care: functionality is deactivated

Function	Setting / Description
C2 Output	
C2.1 Current Output	2-wire current output 4..20 mA (for details refer to <i>Technical data</i> on page 99)
C2.1.1 Current Out. Meas.	Determination of measurement variable for current output. Measurement variable for current output is pre-set according to application data. Select: Volume Flow / Norm. Volume Flow / Mass Flow / Density / Temperature1 / Pressure / Vortex Frequency / Velocity / Gross Power / Net Power / FAD The latter three measurement variables are just available if the respective meter type option was activated.
C2.1.2 0% Range	The set value represents the 4 mA value of the current output. Usually 0% of flow is set as 4 mA, but it is also possible to assign higher flow values than 4 mA.
C2.1.3 100% Range	The set value represents the 20 mA value of the current output. Usually 100% of flow is set as 20 mA, but it is also possible to assign lower flow values than 20 mA.
C2.1.4 Lower Ext. Range	Minimum limit of current value. Pre-set value is 4 mA. Enter: 3.8...4 mA Condition for value < 4 mA: Measurement value at 4 mA must not be smaller or equal to 0%.
C2.1.5 Upper Ext. Range	Maximum limit of current value. Pre-set value is 20 mA. Enter: 20...20.5 mA Condition for value > 20 mA: Measurement value at 20 mA must not be greater or equal to 100%.
C2.1.6 Error Function	This function triggers a current output signal in case of an error detection with status type F (for details refer to <i>Status messages and diagnostic information</i> on page 87). Select: - Off: No error current signal is sent. - High: Error current signal as defined in C2.1.7 is sent. - Low: Error current signal as defined in C2.1.8 is sent. - Hold: Last current value is held.
C2.1.7 Low Error Current	Enter: 3.5...3.6 mA, available if "Error Function = Low"
C2.1.8 High Error Current	Enter: 21...21.5 mA, available if "Error Function = High"
C2.1.9 Trimming	This function enables to trim the current output. Trimming is started by entering the menu.
C2.1.9.2 4mA Trimming	Trimming of 4 mA point. Enter measured value for 4 mA point. Reset to 4 mA restores the factory calibration.
C2.1.9.5 20mA Trimming	Trimming of 20 mA point. Enter measured value for 20 mA point. Reset to 20 mA restores the factory calibration.
C2.2 Binary Output	For possible functions of the binary output refer to <i>Binary output</i> on page 40

Function	Setting / Description
C2 Output	
C2.2.1 Function	Select: Off / Pulse / Frequency / Status / Limit Switch Unless otherwise ordered the binary output is inactive.
C2.2.2 Pulse Output	Only available if "Pulse" is selected in C2.2.1.
C2.2.2.1 Measurement	Select: Volume Flow / Mass Flow / Norm. Volume Flow / Gross Power / Net Power Gross/net power is just available for non-standard meter types measuring steam or water. Availability of selection depending on meter type and medium configuration.
C2.2.2.2 Value p. Pulse	Define value per pulse in unit according to measurement variable selection.
C2.2.2.3 Pulse Width	Define pulse width in ms.
C2.2.2.4 100% Pulse Rate	Define 100% pulse rate in Hz.
C2.2.3 Frequency Output	Only available, if "Frequency" is selected in C2.2.1.
C2.2.3.1 Frequency Out. Meas.	Select: Volume Flow / Norm. Volume Flow / Mass Flow / Density / Temperature1 / Temperature2 / Pressure / Vortex Frequency / Velocity / Specific Enthalpy / Specific Heat Capacity / Reynolds Number / FAD / Net Power / Gross Power Availability of selection depending on meter type and medium configuration.
C2.2.3.2 Pulse Shape	Select: Automatic (constant pulse width based on pulse/pause ratio = 1 at max. pulse rate) / Symmetric (pulse/pause ratio = 1) / Fixed (Fixed pulse length; set pulse width in C2.2.3.3)
C2.2.3.3 Pulse Width	Only available, if "Pulse Shape = Fixed" is selected in C2.2.3.2. Enter pulse width in ms.
C2.2.3.4 0% Pulse Rate	Enter value for 0% pulse rate in Hz.
C2.2.3.5 100% Pulse Rate	Enter value for 100% pulse rate in Hz.
C2.2.3.6 0% Range	Enter value for 0% range in unit according to measurement variable selection.
C2.2.3.7 100% Range	Enter value for 100% range in unit according to measurement variable selection.
C2.2.4 Status Output	Only available, if "Status" is selected in C2.2.1.
C2.2.4.1	Selection can be made, which event will trigger a signal on the status output. Select: - Flow Totalizer Overfl.: Signal is sent, when pre-defined flow totalizer value is reached. Define value in C4.1.2. - Energy Totalizer Overf.: Signal is sent, when pre-defined energy totalizer value is reached. Define value in C4.2.2. - Failure: Status signal is sent in case of failure. - Function Check: Status signal is sent, if a test function is active. - Out of Specification: Signal is sent, if measurement is out of specification. - Type of Fluid (for steam applications): Signal is sent to signalise transition in type of fluid.
C2.2.4.2 Type of Fluid	Only available, if "Type of Fluid" is selected in C2.2.4.1. Select (availability depending on fluid and medium configuration): - Liquid: Indicates transition of medium to liquid. - Saturated Steam: Indicates transition of medium to saturated steam. - Superheated Steam: Indicates transition of medium to superheated steam. Note: Correct temperature and pressure sources have to be defined in C1.6 and C1.7!
C2.2.4.3 Type of Fluid Epsilon	Only available, if "Type of Fluid" is selected in C2.2.4.1. Value defines the sensitivity of transition detection. Enter value between -1.0 (to decrease sensitivity) and +1.0 (to increase sensitivity).
C2.2.5 Limit Switch	Only available, if "Limit Switch" is selected in C2.2.1.

Function	Setting / Description
C2 Output	
C2.2.5.1 Measurement	<p>Limit output variable can be defined, which will trigger a signal on the status output.</p> <p>Select: Volume Flow / Norm. Volume Flow / Mass Flow / Volume / Density / Temperature1 / Temperature2 / Pressure / Vortex Frequency / Velocity / Specific Enthalpy / Specific Heat Capacity / Reynolds Number / Mass / Norm. Volume / FAD / Net Energy / Gross Energy / Net Power / Gross Power</p> <p>The latter five measurement variables are just available if the respective meter type option was activated and fluid/medium were properly configured.</p> <p>Availability of selection depending on meter type and medium configuration.</p>
C2.2.5.2 Lower Limit	Enter value for lower limit in unit according to selected limit output variable.
C2.2.5.3 Upper Limit	Enter value for upper limit in unit according to selected limit output variable.
C2.2.6 Invert Signal	Select: On (normally open) / Off (normally closed)

Function	Setting / Description
C3 Communication	
C3.1 HART	
C3.1.1 Current Loop Mode	Select: On (enables primary variable to be transmitted as 4...20 mA current values) / Off (disables 4...20 mA transmission, but enables HART® multi-drop mode)
C3.1.2 Identification	HART® Identification parameters
C3.1.2.1 Polling Address	<p>Set address for HART® operation. Standard setting is 000 for point-to-point operation with current output 4...20 mA. Setting of polling address ≠ 000 causes a constant 4 mA output and enables multi-drop mode.</p> <p>Enter: 000...063</p>
C3.1.2.2 Tag	Enter measuring point identifier (1...8 digits).
C3.1.2.3 Long Tag	<p>Enter long measuring point identifier (1...32 digits).</p> <p>Entry will be displayed in the header bar on the LC display (depending on letter size, min. 11 digits can be displayed).</p>
C3.1.2.4 Manufacturer ID	HART® Manufacturer ID = 00069 (0x45) [KROHNE] (read-only)
C3.1.2.5 Device Type	Device Type = 00205 (0xCD) (read-only)
C3.1.2.6 Device ID	Individual device ID (read-only)
C3.1.2.7 Universal Revision	HART® revision (read-only)
C3.1.2.8 Device Revision	(read-only)
C3.1.2.9 Software Revision	(read-only)
C3.1.2.10 Hardware Revision	(read-only)
C3.1.3 Device Information	Informative text can be added to describe the device in the HART® communication loop.
C3.1.3.1 Descriptor	Commenting text to label instrument can be added; 1...16 digits.
C3.1.3.2 Message	Here additional information can be added.
C3.1.3.3 Date	Customer-defined date can be set here.
C3.1.3.4 Cfg. Change Counter	Counter for changes in settings (read-only).
C3.1.4 HART Variables	Definition of HART® variables.
C3.1.4.1 Current Out. Meas.	Primary HART® variable; identical with current output measurement variable.

Function	Setting / Description
C3 Communication	
C3.1.4.2 Frequency Out. Meas.	Secondary HART® variable; identical with frequency output measurement variable. If binary output is not activated or not configured as frequency output, the secondary HART® variable is selectable. The variable selection is depending on the device configuration.
C3.1.4.3 Current Input Meas.	Tertiary HART® variable; identical with current input measurement variable. If the current input is not activated, the secondary HART® variable is selectable. The variable selection is depending on the device configuration.
C3.1.4.4 Quaternary HART	Select (Availability depending on fluid and medium configuration): Volume Flow / Norm. Volume Flow / Mass Flow / Gross Power / Net Power / FAD / Volume / Norm. Volume / Gross Energy / Net Energy / Density / Temperature1 / Temperature2 / Pressure / Vortex Frequency / Velocity / Specific Enthalpy / Specific Heat Capacity / Reynolds Number
C3.1.5 Catch DV Temp.	Catch device variable allows for capturing process data from another field device in a multidrop network.
C3.1.5.1 Capture Mode	ACK - listen to responses by a specific slave device BACK - listen to bursts by a specific slave device OFF - disable capture mode
C3.1.5.2 Exp. Device Type	Define expanded device type for source slave. Enter: 000...65535
C3.1.5.3 Slave Device ID	Enter source slave address
C3.1.5.4 Capture Command	Select source command number: 1 / 2 / 3 / 9 / 33
C3.1.5.5 Slot Number	Describes slot to process in response message. Select 1...8 (depending on source command number).
C3.1.5.6 Shed Time	Shed time for mapping. Define: 0...max.
C3.1.6 Catch DV Pressure	Same options as C3.1.5.

Function	Setting / Description
C4 Totalizer	
C4.1 Flow Totalizer	
C4.1.1 Measurement	Select: Volume Flow / Norm. Volume Flow / Mass Flow "Norm. Vol." is only available if fluid is "Gas", "Wet Gas" or "Gas Mixture".
C4.1.2 Preset Value	Set value, which triggers signal on status output (refer to C2.2.4.1).
C4.1.3 Reset Totalizer?	Select: Yes / No
C4.1.4 Set Start Value	Set start value in selected unit. Start value has to be confirmed with "Yes" or refused with "No".
C4.1.5 Start Totalizer?	Select: Yes / No
C4.1.6 Stop Totalizer?	Select: Yes / No
C4.1.7 Information	Display of current totalizer values. The menus C4.1.7.1 to C4.1.7.3 are available depending on selected measurement variable in C4.1.1.
C4.1.7.1 Volume	Display of current totalizer value for volume flow.
C4.1.7.2 Norm. Volume	Display of current totalizer value for norm. volume flow.
C4.1.7.3 Mass	Display of current totalizer value for mass flow.

Function	Setting / Description
C4 Totalizer	
C4.2 Energy Totalizer	This menu is available for meter types \neq "Standard" and for medium = "Steam" or "Water".
C4.2.1 Measurement	Select: Gross Energy / Net Energy "Net Energy" is only available, if fluid = "Steam" or medium = "Water".
C4.2.2 Preset Value	Set value, which triggers signal on status output.
C4.2.3 Reset Totalizer?	Select: Yes / No
C4.2.4 Set Start Value	Enter current value in selected unit. Start value has to be confirmed with "Yes" or refused with "No".
C4.2.5 Start Totalizer?	Select: Yes / No
C4.2.6 Stop Totalizer?	Select: Yes / No
C4.2.7 Information	Display of current totalizer values. The menus C4.2.7.1 and C4.2.7.2 are available depending on selected measurement variable in C4.2.1.
C4.2.7.1 Gross Energy	Display of current totalizer value for gross energy.
C4.2.7.2 Net Energy	Display of current totalizer value for net energy.

Function	Setting / Description
C5 Display	
C5.1 Language	Available display languages: German, English, French, Italian, Spanish, Russian, Chinese, Swedish, Danish, Czech, Polish; 15 further languages in preparation (for details refer to <i>Menu languages</i> on page 56)
C5.2 Contrast	Adjust contrast of local display [-10...+10].
C5.3 1. Meas. Page	Configuration of the first measurement display page.
C5.3.1 Function	Select: One Value / Two Values / Three Values / One Value & Bargraph / Two Values & Bargraph
C5.3.2 Measurement 1. Line	Select: Volume Flow / Norm. Volume Flow / Mass Flow / Volume / Norm. Volume / Mass / Temperature1 / Temperature2 / Pressure / Density / Vortex Frequency / Velocity / Specific Enthalpy / Specific Heat Capacity / Reynolds Number The following options are only available for meter types "Heat" / "Heat & Dens. by Pres." / "Heat & Dens. & FAD": Gross Power / Net Power / Gross Energy / Net Energy / FAD (only available with the meter type "Heat & Dens. & FAD")
C5.3.3 0% Range	The set value represents the 0% point of the bargraph indication. Usually 0% flow = 4 mA, but it is also possible to define a higher flow value for 4 mA. This menu is only available, if an option containing a bargraph was selected in C5.3.1.
C5.3.4 100% Range	The set value represents the 100% point of the bargraph indication. Usually 100% flow = 20 mA, but it is also possible to define a lower flow value for 20 mA. This menu is only available, if an option containing a bargraph was selected in C5.3.1.
C5.3.5 Format 1. Line	Automatic or 1...8 digits
C5.3.6 Measurement 2. Line	Same as C5.3.2, visible if more than one value was selected in C5.3.1.
C5.3.7 Format 2. Line	Same as C5.3.5, visible if more than one value was selected in C5.3.1.
C5.3.8 Measurement 3. Line	Same as C5.3.2, visible if three values were selected in C5.3.1.
C5.3.9 Format 3. Line	Same as C5.3.5, visible if three values were selected in C5.3.1.
C5.4 2. Meas. Page	Same options as in C5.3.

Function	Setting / Description
C6 Device	
C6.1 Information	
C6.1.1 Tag	Entry and display of measuring point identifier (8 digits).
C6.1.2 Long Tag	Entry and display of long measuring point identifier (1...32 digits). Entry will be displayed in the header bar on the LC display (depending on letter size, min. 11 digits can be displayed).
C6.1.3 Meter Type	Display of meter type as activated in A10 or C6.3.2...C6.3.4 (read-only).
C6.1.4 Serial Number	Individual device ID (read-only).
C6.1.5 Manufacturer ID	HART [®] Manufacturer ID = 00069 (0x45) [KROHNE] (read-only)
C6.1.6 Device Name	Optiswirl 4200 (read-only)
C6.1.7 V Number	Internal order number (read-only).
C6.1.8 Electronic Revision	Electronic revision of this device as listed on device nameplate (for details refer to <i>Software history</i> on page 6).
C6.1.9 Device Revision	(read-only)
C6.1.10 Software Revision	(read-only)
C6.1.11 Hardware Revision	(read-only)
C6.1.12 Electronic Serial No.	Individual ID of electronics component (read-only).
C6.1.13 CG Number	Article code for signal converter hardware (read-only).
C6.1.14 Production Date	(read-only)
C6.1.15 Calibration Date	(read-only)
C6.2 Security	
C6.2.1 Login	Enter four digit password to gain a specific access level (for details refer to <i>Security and permissions</i> on page 54).
C6.2.2 Change Password	Change the password associated to the access level currently active.
C6.2.3 Reset Passwords	Reset all passwords to their default setting (for details refer to <i>Security and permissions</i> on page 54).
C6.2.4 Unlock SIL	Enter four digit password to unlock SIL mode (if not unlocked by order) and confirm with enter key. For details refer to "Safety Manual".
C6.3 Extras	
C6.3.1 Meter Type	Display of meter type as activated in A10 or C6.3.2...C6.3.4 (read-only).
C6.3.2 Heat	Activate a different meter type in order to enable advanced measurement options (Gross/net heat, density by pressure or FAD) using a unique authorisation code.
C6.3.3 Heat & Dens. by Pres.	
C6.3.4 Heat & Dens. & FAD	Contact manufacturer to obtain this code.
C6.4 Errors	
C6.4.1 Message View	NAMUR messages (F, S, M, C, I) For further information refer to <i>Status messages and diagnostic information</i> on page 87.
C6.4.4 Error Mapping	For specific NE 107 events it is possible to redefine the status type.
C6.4.4.1 Totalizer	This function defines the NE 107 status type for the totalizer overflow. Select: Information / Maintenance Request / Out of Specification / Function Check / Failure / None

Function	Setting / Description
C6 Device	
C6.5 Units	
6.5.1 Volume Flow	C6.5.2 Cst. Volume Flow In all even numbered menus C6.5.2 to .22 Cst. Units (Custom Units) there is a submenu with the prompt for "Text", "Offset" and "Factor".
6.5.3 Norm. Vol. Flow	6.5.4 Cst. Norm. Vol. Flow
6.5.5 Mass Flow	6.5.6 Cst. Mass Flow
6.5.7 Power	6.5.8 Cst. Power
6.5.9 Volume	6.5.10 Cst. Volume
6.5.11 Norm. Volume	6.5.12 Cst. Norm. Volume
6.5.13 Mass	6.5.14 Cst. Mass
6.5.15 Energy	6.5.16 Cst. Energy
6.5.17 Pressure	6.5.18 Cst. Pressure
6.5.19 Temperature	6.5.20 Cst. Temperature
6.5.21 Density	6.5.22 Cst. Density
C6.6 Factory Default	
C6.6.1 Reset to Fact. Def.?	Query: Reset to Fact. Def.? Press "→" and confirm reset to factory default with "Yes" or refuse with "No".
C6.8 Proof Test	For details refer to the "Safety Manual".

6.8 Setting examples

6.8.1 Settings for free air delivery measurement - FAD

For the use of the FAD functionality the following parameters have to be entered into the vortex flowmeter:

- Ambient temperature (inlet)
- Atmospheric pressure (inlet)
- Air humidity (inlet and outlet)
- Motor speed (rated speed and actual speed)
- Filter pressure drop

The following configuration example describes an easy way to program all necessary parameters and settings.

Function	Parameters
C6.3 Extras	Activate meter type option "Heat & Dens. & FAD" by entering the proper four digit code (if not activated by order). This needs to be done once.

Enter process parameters:

C1.1 Fluid	Gas
C1.2 Medium	Air
C6.5 Units	Set units for temperature, pressure and flow.
C1.3.3 Inlet Temperature	Enter value in selected unit.
C1.3.4 Atm. Pressure	Enter value in selected unit.
C1.3.5 Filter Pressure Drop	Enter value in selected unit.
C1.3.6 Inlet Rel. Humidity	Enter value in %.
C1.3.7 Outlet Rel. Humidity	Enter value in %.
C1.3.8 Compressor RPM	Enter value in RPM.
C1.3.9 Rated Compr. RPM	Enter value in RPM.

Configure output:

C2.1 Current Output	
C2.1.1 Current Out. Meas.	FAD
C2.1.2 0% Range C2.1.3 100% Range	Enter value for 0% and 100% in selected unit.

Display one value on local display:

C5.3.1 Function	One Value & Bargraph
C5.3.2 Measurement 1. Line	FAD
C5.3.3 0% Range C5.3.4 100% Range	Enter bargraph range limits (0% / 100%) in selected unit.



INFORMATION!

This is an example setup for basic FAD measurement. Other setup options are feasible.

6.8.2 Gross heat measurement

In order to calculate gross power the mass flow (compensated by density) is multiplied by the specific enthalpy:

$$\text{Gross power } [Q_H] = \text{mass flow } [Q_m] \times \text{enthalpy } [H]$$

When measuring gross heat, internally both the flow totalizer and the energy totalizer are used.

The following configuration example describes an easy way to program all necessary settings. For this example is assumed that the internal temperature and pressure sensor are used for the gross heat calculation of superheated steam.

Function	Parameters
C6.3 Extras	Activate one of the meter type options "Heat" (for saturated steam and temperature compensation) or "Heat & Dens. by Pres." (for superheated steam and density compensation by temperature and pressure) by entering the proper four digit code (if not activated by order). This needs to be done once.

Enter process parameters:

C1.1 Fluid	Steam
C1.2 Medium	Superheated Steam
C1.6 Temp. Sensor	
C1.6.1 Temp. Source1	Internal ("Temp. Source2" must not be selected as "Internal")
C1.7 Pressure Sensor	
C.1.7.1 Pressure Source	Internal
C6.5 Units	Set units for temperature, pressure and flow.
C1.10 Operating Values	
C1.10.3 Oper. Density	Operating density is important for sensor limits but will not be used during operation.

Configure output and totalizers:

C2.1 Current Output	
C2.1.1 Current Out. Meas.	Gross Power
C2.1.2 0% Range C2.1.3 100% Range	Enter value for 0% and 100% in selected unit.
C4.2 Energy Totalizer	
C4.2.1 Measurement	Gross Power
C4.2.5 Start Totalizer?	Yes

Display two values on local display: (Gross power, Gross energy)

C5.3.1 Function	Two Values
C5.3.2 Measurement 1. Line	Gross Power
C5.3.6 Measurement 2. Line	Gross Energy



INFORMATION!

This is an example setup for basic gross heat measurement. Other setup options are feasible.

6.8.3 Net heat measurement

To determine the amount of energy, which is consumed by a plant, the gross heat quantity must be reduced by the amount of energy, which is returned to the energy cycle. In the following configuration example it is assumed that the gross heat quantity is determined for superheated steam by the internal sensors and the outlet temperature value is fed into the device via the current input.

Function	Parameters
C6.3 Extras	Activate one of the meter type options "Heat" (for saturated steam and temperature compensation) or "Heat & Dens. by Pres." (for superheated steam and density compensation by temperature and pressure) by entering the proper four digit code (if not activated by order). This needs to be done once.

Enter process parameters:

C1.1 Fluid	Steam
C1.2 Medium	Superheated Steam
C1.5 Current Input	
C1.5.1 Function	On
C1.5.2 Current Input Meas.	Temperature External
C1.6 Temp. Sensor	
C1.6.1 Temp. Source1	Internal
C1.6.2 Temp. Source2	External
C1.7 Pressure Sensor	
C.1.7.1 Pressure Source	Internal
C6.5 Units	Select units of temperature, pressure, volume flow, power and energy.
C1.10 Operating Values	
C1.10.3 Oper. Density	Operating density is important for sensor limits but will not be used during operation.

Configure output and totalizers:

C2.1 Current Output	
C2.1.1 Current Out. Meas.	Net Power
C2.1.2 0% Range C2.1.3 100% Range	Enter value for 0% and 100% in selected unit.
C4.2 Energy Totalizer	
C4.2.1 Measurement	Net Power
C4.2.5 Start Totalizer?	Yes

Display two values on local display: (net power, net energy)

C5.3.1 Function	Two Values
C5.3.2 Measurement 1. Line	Net Power
C5.3.6 Measurement 2. Line	Net Energy



INFORMATION!

This is an example setup for basic net heat measurement. Other setup options are feasible.

6.9 Status messages and diagnostic information





The diagnostic messages are displayed in accordance with NAMUR standard NE 107. The error messages for the device are divided into status groups, each with one status signal. There are 16 status groups with fixed status signals and 8 groups with variable status signals. To facilitate identification of the problem source, the status groups are then divided into: Sensor, Electronics, Configuration and Process.



INFORMATION!

As a status message, always the event group name and the the status signal (F/S/M/C) are displayed.

Each status message (= status signal) has a specific symbol, determined by NAMUR, which is displayed with the message. The length of each message is limited to one line.

Symbol	Letter	Status signal	Description and consequence
	F	Failure	No measurement possible.
	S	Out of specification	Measurements are available but are no longer sufficiently accurate and should be checked.
	M	Maintenance required	Measurements are still accurate but this could soon change.
	C	Function check	A test function is active. The displayed or transferred measured value does not correspond to the actual measured value.
	I	Information	No direct influence on the measurements.



INFORMATION!

Some of the following elimination measures require a hard reset. In case a hard reset is performed please wait for approx. 10 seconds before powering the device again.

Status type	Event group	Single event	Description	Actions to eliminate the event
F	Sensor	Fatal Sensor Error	An internal error in the sensor module has occurred.	Perform a hard reset. If the message recurs, contact the manufacturer.
		No Temperature Sensor	The internal temperature sensor (PT1000) is not connected or its resistance is too high. The process temperature cannot be measured.	Check the pick-up and its connection. Contact the manufacturer, if necessary.
		Sensor Comm. Error	Error in the internal bus communication or hardware failure.	For remote version: Check the sensor connection. All versions: Perform a hard reset. If the message recurs, contact the manufacturer.
		No/Invalid Pressure Sensor	Pressure sensor not available or invalid communication	Check the connection of the pressure sensor. Perform a hard reset. If the message recurs, contact the manufacturer.
		Corrupt Sensor Parameter	Sensor parameters are inconsistent	Check sensor parameters.
		Failed Sensor Input Test	The continuous self test of the sensor electronic failed.	Perform a hard reset. If the message recurs, contact the manufacturer.
		Failed Sensor MCU Test	The continuous self test of the sensor electronic failed.	Perform a hard reset. If the message recurs, contact the manufacturer.
		Temperature Sensor Error	The resistance of the internal temperature sensor (PT1000) is too low.	Check the pick-up and its connection. Perform a hard reset. Contact the manufacturer, if necessary.
		No Measurement Value	Q_v or Q_m have timed out or are inconsistent.	For remote version: Check the sensor connection. All versions: Perform a hard reset. If the message recurs, contact the manufacturer.
				Temporary Piezo Error
Fatal Piezo Error	Piezo signals disturbed.			Check the process conditions, proper shielding/grounding and the installation situation. Perform a hard reset. If the message recurs, contact the manufacturer.
Piezo Path disrupted	Sensor electronics error.			Perform a hard reset. If the message recurs, contact the manufacturer.
Piezo Shortcut	Shortcut on piezo or sensor electronics detected.			Perform a hard reset. If the message recurs, contact the manufacturer.

Status type	Event group	Single event	Description	Actions to eliminate the event
F	Electronics			
		Fatal DM Error	Internal error.	Perform a hard reset. If the message recurs, contact the manufacturer.
		Fatal CO Error	Internal error.	
		Fatal Converter Error	An electronics or hardware failure has occurred.	
		Emergency Off active	The current output has triggered a safety reaction and is signaling a failure current below 3.6 mA or above 21 mA.	Follow the instructions of the "Safety Manual".
		Internal Comm. Error	Error in the internal bus communication.	Perform a hard reset. If the message recurs, contact the manufacturer.
		Inconsistent Parameters	Error in the internal bus communication.	Check the parameters and make sure that the set of data is consistent. Additional information on the error can be called via HART® interface.
		Sensor Comm. Error	Error in the internal bus communication or hardware failure.	Perform a hard reset. If the message recurs, contact the manufacturer.
		Power Supply Error	Internal voltage too low to switch on sensor power supply.	Check power supply connection or replace the electronics.
		Sensor/Conv. FW Mismatch	Incompatible firmware versions in the sensor and the converter module.	Perform a hard reset. If the message recurs, contact the manufacturer.
		Max. Number of Restarts	The device could not start the measuring mode after a cold starting.	Perform a hard reset once again. If the message recurs, contact the manufacturer.
		Converter Overvoltage	An electronics or hardware failure has occurred.	Perform a hard reset. If the message recurs, contact the manufacturer.
	Intern. Comm. Error	Error in the internal bus communication.	Perform a hard reset. If the message recurs, contact the manufacturer.	
F	Configuration			
		Voting Error	Same flow calculation on redundant processors have yielded different results.	Perform a hard reset. If the message recurs, contact the manufacturer.
		Inconsistent NVRAM	Inconsistent data in the parameter memory.	
		Error Starting SIL Mode	-	
		CO Float Error	Error in processing of the measuring value due to inconsistent set of parameter.	Load the factory settings and perform a hard reset. If the message recurs, contact the manufacturer.
		Incons. Converter Calib.	Faulty calibration data in the converter module.	Contact the manufacturer.
	Incons. Sensor Calibration	Faulty calibration data in the sensor module.		

Status type	Event group	Single event	Description	Actions to eliminate the event
F		NVRAMs Mismatch	Incompatible serial numbers of display and electronic module.	Use displays and electronic modules, which belong together. Contact the manufacturer, if necessary.
		Conv. NVRAM Layout Error	Incompatible data in parameter memory.	Perform a hard reset. If the message recurs, contact the manufacturer.
		Disp. NVRAM Layout Error	Incompatible data after firmware update.	
		SIL Verification Required	SIL mode is requested. A verification (maintenance mode 2) has to be performed by the operator.	Verify the parameters for the SIL mode according to the instructions of the safety manual and confirm the correctness with the SIL jumper.
C	Electronics			
		Firmware Update Active	A firmware update of the converter module has been started.	Wait for firmware update to finish.
C	Configuration			
		Sensor Sim. Active	A simulation of the sensor is active.	Stop the simulation of the sensor variables.
		Current Out. Sim. Active	A simulation of the current output is active.	Stop the simulation of the current output variables
		Current In. Sim. Active	A simulation of the current input is active.	Stop the simulation of the current input variables
		HART Sim. Active	Simulation of a measuring value via HART® interface.	Stop the simulation via the HART® interface.
		Flow Comp. Sim. Active	A simulation of measurement value processing is active.	Stop the simulation of the measurement value processing.
		Binary Output Sim. Active	A simulation of the binary output is active.	Stop the simulation of the binary output variables.
		Totalizer Sim. Active	A simulation of the totalizer is active.	Stop the simulation of the totalizer variables.
		SIL Proof test	Device is in maintenance mode 3 (proof test for SIL).	Perform the test according to the instruction in the "Safety Manual".
		Parameterization Test	Device is in maintenance mode 3 (parameterization test).	

Status type	Event group	Single event	Description	Actions to eliminate the event
S	Sensor			
		Flow Meas. Out of Spec.	The vortex frequency or the volume flow is out of range. The real flow is higher or lower than the indicated value.	Check the process conditions.
		Low Flow Cutoff Undercut	Volume flow is lower than low flow cutoff (LFC)	Check the low flow cut-off or the process conditions.
		Weak Flow Meas. Signal	The vortex signal is too weak or disturbed.	Check the process conditions and the installation situation. Eliminate external disturbances. If the message recurs, contact the manufacturer.
		Pres.Sen.Temp. Out of Spec.	Temperature of the internal pressure sensor out of specification.	Make sure that the device is operated within the permissible temperature range.
		Elec. Temp. Out Of Spec.	The electronic temperature of the sensor module is out of specification.	
S	Electronics			
		Elec. Temp. Out Of Spec.	The electronic temperature of the converter is out of specification.	Make sure that the device is operated within the permissible temperature range.
S	Process			
		CO Undersaturation	The measurement value is lower than the lower range value of the current output. The current output is saturated and does not reflect the effective measuring value.	Check the process conditions and the lower current output limit.
		CO Oversaturation	The measurement value is higher than the upper range value of the current output. The current output is saturated and does not reflect the effective measuring value.	Check the process conditions and the upper current output limit.
S	Config: Totalizer			
		Flow Totalizer Overflow	The actual value of the flow counter exceeds its preset value.	Check the setting of the flow counter or reset the counter.
		Energy Totalizer Overflow	The actual value of the energy counter exceeds its preset value.	The actual value of the energy counter exceeds its preset value.
M	Sensor Information			
		Faulty Sensor Oscillator	The sensor oscillator is working out of range.	Perform a hard reset. If the message recurs, contact the manufacturer.
	Faulty sensor voltage ref.	Reference voltage in sensor module out of specification.		

Status type	Event group	Single event	Description	Actions to eliminate the event
M	Electronics Information			
		Faulty Converter Oscillator	The converter oscillator is working out of range.	Perform a hard reset. If the message recurs, contact the manufacturer.
		Faulty conv. voltage ref.	Reference voltage in converter module out of specification.	
C	Process			
		Heater / Cooler Error	During net heat metering the difference in temperature is reversed.	Check net heat metering setup. Check temperature input configuration.

6.10 A12 plausibility checks

When configuring the device, a number of complex "cluster" checks are run internally on the proposed configuration in order to make sure it is valid. Thus when saving a configuration the device might raise an error like this: "Failed E01", which indicates an error cluster number. In this case please consult the indicated cluster number in the following table to find out which parameters are affected.

You may also want to enter in the quick setup menu "A12 Cluster Checks" and check each setting in the affected "cluster" submenu.

No.	Name	Explanation of plausibility checks
01	Sensor Configuration / Fluid	After changing fluid, operating density or operating temperature the device checks whether the measurement variables configured at the device's outputs are still valid (HART [®] variables, frequency output, pulse output, status output, limit switch, local display and flow totalizer). Also their configured ranges are checked.
02	Medium	When selecting the medium the device checks whether the measurement variables configured at the device's outputs are still valid (HART [®] variables, frequency output, pulse output, status output, limit switch, local display and flow totalizer). Additionally the configuration of temperature sources and pressure sources is checked.
03	Meter Type	When changing the meter type the device will check whether the measurement variables configured at the device's outputs are still valid (HART [®] variables, frequency output, pulse output, status output, limit switch, local display and flow totalizer). It also checks if the currently selected medium is supported by the new meter type as well as the configuration of temperature sources and pressure sources.
04	Temperature / Pressure	Checks configuration of temperature sources and pressure sources.
05	Current output / primary HART variable	Checks if selected measurement variable is valid. Also checks limit settings for 0% and 100%.
06	Frequency output / Secondary HART variable	Checks if the frequency output/secondary HART [®] variable is valid. Also checks if the selected measurement variable is available in this context and if its range is valid.
07	Current input / Tertiary HART variable	If the current input is selected to provide temperature or pressure measurement data, the device checks the configuration of temperature sources and pressure sources. It also checks if the current input range (4 mA / 20 mA) is valid.
08	Quaternary HART Variable	Checks if the measurement variable configured as quaternary HART [®] variable is valid.
09	Flow Totalizer	Checks if the measurement variable selected for the flow totalizer (volume flow, standard volume flow, mass flow) is valid. Also checks configuration of the HART [®] variables, limit switch and local display.
10	Measurement Display Pages	Checks if the measurement variables selected on both measurement display pages are valid. If a bar graph is displayed its ranges are also checked.
11	Gas Mix Total	If a gas mixture is selected as medium, the device checks if all individual gas components add up to 100%.
12	HART Catch Variable (Temperature / Pressure)	If temperature or pressure data input is provided by HART [®] , the device checks if the "Slot Number" fits in with the "Capture Command".

7.1 Replacing signal converter / LC display

The signal converter has to be replaced by a converter of the same type. The item number ⑦ must match: 40021445xx

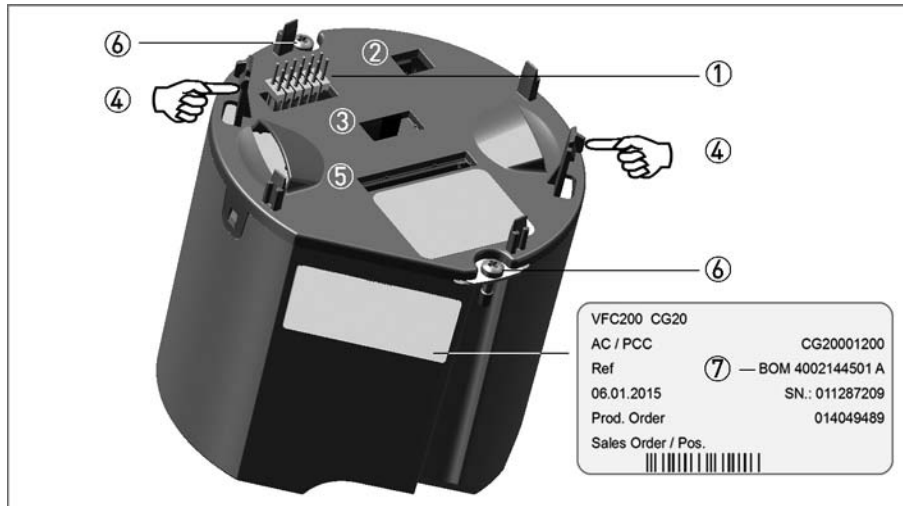

Figure 7-1: Connect transmitter module

- ① Connector for LC display
- ② Service connector
- ③ SIL connector
- ④ Display brackets
- ⑤ Connection to the flow sensor
- ⑥ Fixing screw
- ⑦ Item number



The following steps are to be performed:

- Switch off the power supply.
- Unscrew the front cover with the key.
- Use the handle to pull out the display by plugging into the brackets ④ and gently pulling it out.
- Detach the flow sensor connection ⑤.
- Loosen the two fixing screws ⑥.
- Pull out signal converter.
- Insert new signal converter.
- Tighten the two screws ⑥.
- Attach the flow sensor cable ⑤.
- Attach display ① in desired position, apply even pressure to the entire surface.
- Screw on cover by hand.

7.2 Maintaining the O-rings

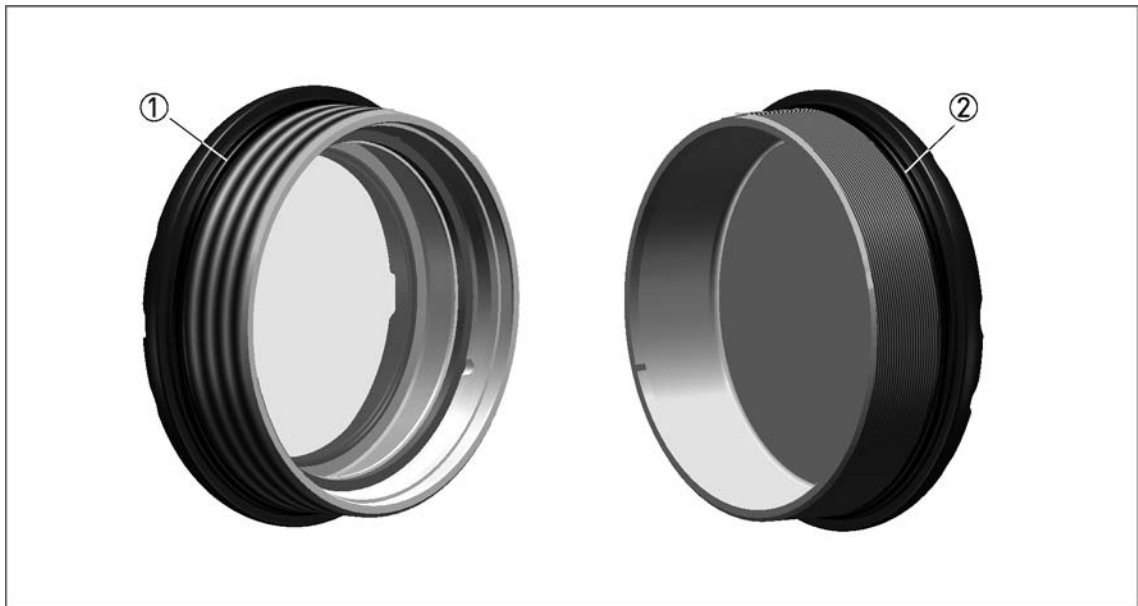

Figure 7-2: Maintaining the O-rings

- ① Display cover
- ② Rear cover

Whenever either the display cover ① or the rear cover ② of the housing is opened and closed again, make sure that the O-rings are well greased or being replaced if need be (O-ring 94x2,5-NBR-70K, ISO 3601-1).



CAUTION!

Use proper multi-purpose grease covering the full operational temperature range to treat the O-rings with the following properties:

- Operational temperature range [-30...+130°C / -22...+266°F at permanent lubrication]
- Free from silicone
- Good adhesive capability
- Lithium saponified
- Water resistant
- Compatible with material of O-ring

7.3 Spare parts availability

The manufacturer adheres to the basic principle that functionally adequate spare parts for each device or each important accessory part will be kept available for a period of 3 years after delivery of the last production run for the device.

This regulation only applies to spare parts which are subject to wear and tear under normal operating conditions.

7.4 Availability of services

The manufacturer offers a range of services to support the customer after expiration of the warranty. These include repair, maintenance, technical support and training.



INFORMATION!

For more precise information, please contact your local sales office.

7.5 Returning the device to the manufacturer

7.5.1 General information

This device has been carefully manufactured and tested. If installed and operated in accordance with these operating instructions, it will rarely present any problems.



WARNING!

Should you nevertheless need to return a device for inspection or repair, please pay strict attention to the following points:

- *Due to statutory regulations on environmental protection and safeguarding the health and safety of the personnel, the manufacturer may only handle, test and repair returned devices that have been in contact with products without risk to personnel and environment.*
- *This means that the manufacturer can only service this device if it is accompanied by the following certificate (see next section) confirming that the device is safe to handle.*



WARNING!

If the device has been operated with toxic, caustic, radioactive, flammable or water-endangering products, you are kindly requested:

- *to check and ensure, if necessary by rinsing or neutralising, that all cavities are free from such dangerous substances,*
- *to enclose a certificate with the device confirming that it is safe to handle and stating the product used.*

7.5.2 Form (for copying) to accompany a returned device



CAUTION!

To avoid any risk for our service personnel, this form has to be accessible from outside of the packaging with the returned device.

Company:		Address:	
Department:		Name:	
Tel. no.:		Fax no. and/or Email address:	
Manufacturer's order no. or serial no.:			
The device has been operated with the following medium:			
This medium is:	<input type="checkbox"/>	radioactive	
	<input type="checkbox"/>	water-hazardous	
	<input type="checkbox"/>	toxic	
	<input type="checkbox"/>	caustic	
	<input type="checkbox"/>	flammable	
	<input type="checkbox"/>	We checked that all cavities in the device are free from such substances.	
<input type="checkbox"/>	We have flushed out and neutralized all cavities in the device.		
We hereby confirm that there is no risk to persons or the environment through any residual media contained in the device when it is returned.			
Date:		Signature:	
Stamp:			

7.6 Disposal



LEGAL NOTICE!

Disposal must be carried out in accordance with legislation applicable in your country.

Separate collection of WEEE (Waste Electrical and Electronic Equipment) in the European Union:



According to the directive 2012/19/EU, the monitoring and control instruments marked with the WEEE symbol and reaching their end-of-life **must not be disposed of with other waste**.

The user must dispose of the WEEE to a designated collection point for the recycling of WEEE or send them back to our local organisation or authorised representative.

8.1 Functional principle

Vortex flowmeters are used to measure the flow of gases, vapours and liquids at completely filled pipes.

The measuring principle is based on the Karman vortex street. The measuring tube contains a bluff body at which vortex shedding occurs and which is detected by a sensor unit located behind. The frequency f of the vortex shedding is proportional to the flow velocity v . The non-dimensional Stouhal number S describes the relationship between vortex frequency f , width b of the bluff body and the average flow velocity v :

$$f = \frac{S \cdot v}{b}$$

The vortex frequency is recorded at the flow sensor and evaluated at the signal converter.

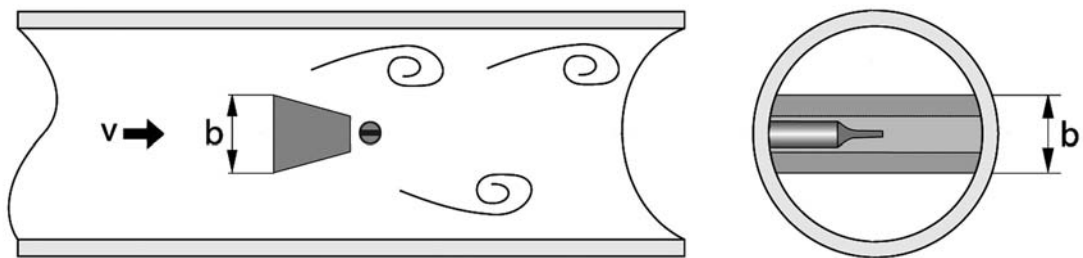

Figure 8-1: Functional principle

8.2 Technical data



INFORMATION!

- The following data is provided for general applications. If you require data that is more relevant to your specific application, please contact us or your local sales office.
- Additional information (certificates, special tools, software,...) and complete product documentation can be downloaded free of charge from the website (Downloadcenter).

Measuring system

Application range	Flow measurement of liquids, gases and vapours
Function / Measuring principle	Karman vortex street

Measurement

Primary measured value	Number of separated vortices
Secondary measured value	Operating and standard volume flow and mass flow

Signal converter

Versions	Compact
	Remote version (in preparation) Cable length: ≤ 50 m / 164 ft

Flow sensor

Standard	Flange version (with integrated temperature measurement), flow sensor: F
	Sandwich version (with integrated temperature measurement), flow sensor: S
Option	Basic device with additional pressure measurement
	Basic device with additional pressure measurement and shut-off valve for pressure sensor
	Dual measuring device in both flange and sandwich version (redundant measurement)
	Dual measuring device with additional pressure measurement
	Flange version with single reduction of nominal diameter, flow sensor: F1R
	Flange version with double reduction of nominal diameter, flow sensor: F2R

Display and user interface

Local display	Graphic display
Interface and display languages	German, English, French, Italian, Spanish, Russian, Chinese, Swedish, Danish, Czech, Polish; 15 further languages (in preparation)

Measuring accuracy

Reference condition

Reference conditions	Water at +20°C / +68°F
	Air at +20°C / +68°F and 1.013 bara / 14.7 psia

Maximum measuring error

Volume flow (liquid)	±0.75% of measured value (Re ≥ 20000)
	±2.0% of measured value (10000 < Re < 20000)
Volume flow (gases and steam)	±1.0% of measured value (Re ≥ 20000)
	±2.0% of measured value (10000 < Re < 20000)
Mass flow (gases and steam)	±1.5% of measured value (Re ≥ 20000) ①
	±2.5% of measured value (10000 < Re < 20000) ①
Mass flow (liquid / water)	±1.5% of measured value (Re ≥ 20000)
	±2.5% of measured value (10000 < Re < 20000)
Normalised volume flow (gas)	±1.5% of measured value (Re ≥ 20000) ①
	±2.5% of measured value (10000 < Re < 20000) ①
Repeatability (volume flow)	±0.1% of measured value

① The maximum error of measurement refers to measurement at an operating pressure >65% of the full scale value of the applied pressure sensor.

Note: In SIL mode, deviating measuring errors have to be taken into account. For details refer to the "Safety Manual".

Operating conditions

Temperature

Medium temperature	-40...+240°C / -40...+465°F
Ambient temperature ②	Non-Ex: -40...+85°C / -40...+185°F
	Ex: -40...+65°C / -40...+140°F
Storage temperature	-40...+85°C / -40...+185°F

② Decreasing display contrast outside of the temperature range of 0...+60°C / +32...+140°F.

Pressure

Medium pressure	Max. 100 bar / 1450 psi (higher pressures on request)
Ambient pressure	Atmosphere

Media properties

Density	Taken into consideration when sizing.
Viscosity	< 10 cP
Reynold's number	> 10000

Recommended flow velocities

Liquids ③, ④	0.3...7 m/s / 0.98...23 ft/s (optional up to 10 m/s / 32.8 ft/s taking cavitation into account)
Gases and steam ③	2.0...80 m/s / 6.6...262.5 ft/s
	DN15: 3.0...45 m/s / 9.8...148 ft/s; DN25: 2.0...70 m/s / 6.6...230 ft/s
③ These values represent the absolute limits of flow velocities. For more detailed information for your specific application refer to <i>Intended use</i> on page 7.	
④ $v_{min} = 0.7$ m/s / 2.3 ft/s in SIL mode	

Other conditions

Ingress protection	Compact version: IP66/67
	Remote version: signal converter housing: IP66/67; flow sensor housing: IP66/67

Installation conditions

Inlet section	≥ 15 x DN without disturbing flow, after pipe narrowing, after a single 90° bend
	≥ 30 x DN after a double bend 2x90°
	≥ 40 x DN after a double three-dimensional bend 2x90°
	≥ 50 x DN after control valves
	≥ 2 DN before flow straightener; ≥ 8 DN after flow straightener
Outlet section	≥ 5 x DN

Materials

Flow sensor and process connections	Standard: 1.4404 / 316L
	Option: Hastelloy® C-22 on request
Electronics housing	Aluminium die-cast, two-layer coating (epoxy/polyester)
	Option: die-cast aluminium with finish for advanced requirements
Pressure sensor gasket	Standard: FPM
	Option: FFKM
Measuring tube gasket (Pick-up)	Standard: 1.4435 / 316L
	Option: Hastelloy® C-276
	Selection depends on flow sensor material / medium.

Process connections of flange version

DIN EN 1092-1	DN15...300 - PN16...100 (higher pressures on request)
ASME B16.5	1/2...12" - 150...600 lb (higher pressures on request)
JIS B 2220	DN15...300 - JIS 10...20 K (higher pressures on request)
For detailed information on combination flange/pressure rating, refer to section "Dimensions and weights".	

Process connections of sandwich version

DIN	DN15...100 - PN100 (higher pressures on request)
ASME	1/2...4" - 600 lb (higher pressures on request)
JIS	DN15...100 - 10...20 K (higher pressures on request)

Electrical connections

Power supply	Non-Ex: 12...36 VDC
	Ex i: 12...30 VDC
	Ex d: 12...36 VDC

Inputs and outputs

General	All inputs and outputs are electrically isolated from one another.
Time constant	The time constant corresponds to 63% of the elapsed time of a processor procedure. 0...100 seconds (rounded up to 0.1 seconds)

Current output

Type	4...20 mA HART® (passive)
Output data	Volume flow, mass flow, norm. volume flow, gross/net power, free air delivery, density, temperature (internal sensor), pressure, vortex frequency, flow velocity
Resolution	5 µA
Linearity / accuracy	0.1% (of read value)
Temperature coefficient	50 ppm/K (typically), 100 ppm/K (max.)
Error signal	According to NE 43
Description of abbreviations	U_{ext} = external voltage; R_L = load + resistance
Load	Minimum 0 Ω; maximum $R_L = ((U_{ext} - 12 \text{ VDC}) / 22 \text{ mA})$

HART®

	HART® protocol via passive current output
HART® revision	HART® 7 Burst mode Catch device
Manufacturer ID	00069 (0x45)
Device type code	00205 (0xCD)
System requirements	Load min. 250 Ω
Multidrop operation	4 mA

Binary output

Function	Pulse, frequency, status, limit switch
Type	Passive Proximity sensor acc. to DIN EN 60947-5-6 (NAMUR sensor) or pulse output signal acc. to VDI/VDE 2188 (category 2)
Temperature coefficient	50 ppm/K
Residual current	< 0.2 mA at 32 V ($R_i = 180 \text{ k}\Omega$)
Pulse width	0.5...2000 ms

Pulse output

Output data	Volume, mass, norm. volume, gross/net energy
Pulse rate	Max. 1000 pulses/s
Power supply	Non-Ex: 24 VDC as NAMUR or open < 1 mA, maximum 36 V, closed 120 mA, U < 2 V
	Ex: 24 VDC as NAMUR or open < 1 mA, maximum 30 V, closed 120 mA, U < 2 V

Frequency output

Output data	Volume flow, mass flow, norm. volume flow, gross/net power, free air delivery, density, temperature (internal sensor or via external input), pressure, vortex frequency, flow velocity, spec. enthalpy, spec. heat capacity, Reynolds number
Max. frequency	1000 Hz

Status output

Output data	Status acc. to NE 107 (F, S, C), flow totalizer overflow, energy totalizer overflow, fluid type (in steam applications)
-------------	---

Limit switch

Output data	Volume flow, mass flow, norm. volume flow, volume, mass, norm. volume, gross/net power, gross/net energy, free air delivery, density, temperature (internal sensor or via external input), pressure, vortex frequency, flow velocity, spec. enthalpy, spec. heat capacity, Reynolds number
-------------	--

Current input

Type	4...20 mA (passive)
Resolution	6 µA
Linearity / accuracy	0.1% (of read value)
Temperature coefficient	100 ppm/K (typically), 200 ppm/K (max.)
Voltage drop	10 V

Approvals and certificates

ATEX	ATEX II2 G - Ex ia IIC T6...T2 Gb ATEX II2 G - Ex d ia IIC T6...T2 Gb ATEX II3 G - Ex nA IIC T6...T2 Gc ATEX II2 D - Ex tb IIIC T70°C Db
IECEX	IECEX - Ex ia IIC T6...T2 Gb IECEX - Ex d ia IIC T6...T2 Gb IECEX - Ex nA IIC T6...T2 Gc IECEX - Ex tb IIIC T70°C Db
QPS (USA & Canada)	QPS Ordinary Locations QPS IS Class I Div 1 QPS XP Class I Div 1 QPS NI Class I Div 2 QPS DIP Class II, III Div 1
Further approvals on request.	

8.3 Dimensions and weights

8.3.1 Flange versions

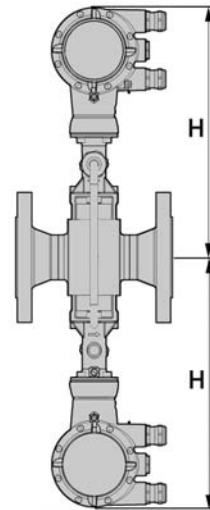
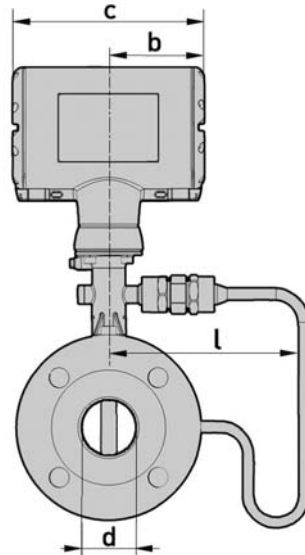
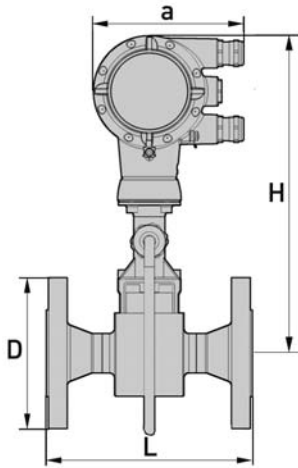

a = 148.5 mm / 5.85"

b = 85.8 mm / 3.38"
c = 171.5 mm / 6.76"

Option:
Version with two signal converter

Dimensions of flange version EN 1092-1 [mm]

Nominal size DN	Pressure rating PN	d	D	L	H	H F1R ①	H F2R ②	l	l F1R ①	l F2R ②
15	40	17.3	95	200	358.8	-	-	169.3	-	-
15	100	17.3	105	200	358.8	-	-	169.3	-	-
25	40	28.5	115	200	358.3	358.8	-	169.3	169.3	-
25	100	28.5	140	200	358.3	358.8	-	169.3	169.3	-
40	40	43.0	150	200	362.3	358.3	358.8	169.5	169.3	169.3
40	100	42.5	170	200	362.3	358.3	358.8	169.5	169.3	169.3
50	16	54.5	165	200	368.3	362.3	358.3	169.5	169.5	169.3
50	40	54.5	165	200	368.3	362.3	358.3	169.5	169.5	169.3
50	63	54.5	180	200	368.3	362.3	358.3	169.5	169.5	169.3
50	100	53.9	195	200	368.3	362.3	358.3	169.5	169.5	169.5
80	16	82.5	200	200	380.3	368.3	362.3	169.3	169.5	169.5
80	40	82.5	200	200	380.3	368.3	362.3	169.3	169.5	169.5
80	63	81.7	215	200	380.3	368.3	362.3	169.3	169.5	169.5
80	100	80.9	230	200	380.3	368.3	362.3	169.3	169.5	169.5
100	16	107	220	250	396.8	380.3	368.3	171.5	169.3	169.5
100	40	107	235	250	396.8	380.3	368.3	171.5	169.3	169.5
100	63	106.3	250	250	396.8	380.3	368.3	171.5	169.3	169.5
100	100	104.3	265	250	396.8	380.3	368.3	171.5	169.3	169.5

Nominal size DN	Pressure rating PN	d	D	L	H	H F1R ①	H F2R ②	l	l F1R ①	l F2R ②
150	16	159.3	285	300	416.3	396.8	380.3	191.5	171.5	169.3
150	40	159.3	300	300	416.3	396.8	380.3	191.5	171.5	169.3
150	63	157.1	345	300	416.3	396.8	380.3	191.5	171.5	169.3
150	100	154.1	355	300	416.3	396.8	380.3	191.5	171.5	169.3
200	10	206.5	340	300	442.1	416.3	396.8	202.8	191.5	171.5
200	16	206.5	340	300	442.1	416.3	396.8	202.8	191.5	171.5
200	25	206.5	360	300	442.1	416.3	396.8	202.8	191.5	171.5
200	40	206.5	375	300	442.1	416.3	396.8	202.8	191.5	171.5
250	10	260.4	395	380	468.8	442.1	416.3	229.5	202.8	191.5
250	16	260.4	405	380	468.8	442.1	416.3	229.5	202.8	191.5
250	25	258.8	425	380	468.8	442.1	416.3	229.5	202.8	191.5
250	40	258.8	450	380	468.8	442.1	416.3	229.5	202.8	191.5
300	10	309.7	445	450	492.8	468.8	442.1	255	229.5	202.8
300	16	309.7	460	450	492.8	468.8	442.1	255	229.5	202.8
300	25	309.7	485	450	492.8	492.8	442.1	255	229.5	202.8
300	40	309.7	515	450	492.8	492.8	442.1	255	229.5	202.8

- ① F1R - single reduction
 ② F2R - double reduction

Weight of flange version EN 1092-1 [kg]

Nominal size DN	Pressure rating PN	with	without	F1R ① with	F1R ① without	F2R ② with	F2R ② without
		Pressure sensor		Pressure sensor		Pressure sensor	
15	40	6.1	5.5	-	-	-	-
15	100	7.1	6.5	-	-	-	-
25	40	7.9	7.3	7.2	6.6	-	-
25	100	9.9	9.3	9.7	9.1	-	-
40	40	10.8	10.2	9.7	9.1	8.9	8.3
40	100	14.8	14.2	13.3	12.7	12.5	11.9
50	16	12.7	12.1	11.4	10.8	10.6	10.0
50	40	12.9	12.3	11.9	11.3	11.2	10.6
50	63	16.9	16.3	15.0	14.4	14.3	13.7
50	100	18.4	17.8	17.2	16.6	16.6	16.0
80	16	17.4	16.8	15.6	15.0	14.2	13.6
80	40	19.4	18.8	17.1	16.5	15.8	15.2
80	63	23.4	22.8	20.3	19.7	19.0	18.4
80	100	27.4	26.8	24.0	23.4	22.8	22.2
100	16	22.0	21.4	21.5	20.9	18.7	18.1
100	40	25.0	24.4	24.9	24.3	22.1	21.5
100	63	30.0	29.4	30.1	29.5	27.4	26.8
100	100	36.0	35.4	36.7	36.1	34.0	33.4
150	16	35.8	35.2	33.9	33.3	32.3	31.7
150	40	41.8	41.2	41.4	40.8	40.2	39.6
150	63	59.8	59.2	58.3	57.7	59.0	58.4
150	100	67.8	67.2	69.2	68.6	70.8	70.2
200	10	38.4	37.8	40.7	40.1	43.1	42.5
200	16	38.4	37.8	40.3	39.7	44.3	43.7
200	25	47.4	46.8	49.5	48.9	50.8	50.2
200	40	55.4	54.8	58.0	57.4	58.5	57.9
250	10	58.0	57.4	63.1	62.5	59.8	59.2
250	16	59.0	58.4	64.7	64.1	61.5	60.9
250	25	75.0	74.4	78.5	77.9	76.8	76.2
250	40	93.0	92.4	96.3	95.7	96.1	95.5
300	10	76.3	75.7	81.1	80.5	85.8	85.2
300	16	82.8	82.2	87.6	87.0	92.9	92.3
300	25	99.3	98.7	105.1	104.5	113.0	112.4
300	40	128.1	127.5	132.0	131.4	143.2	142.6

Weight specifications for version with two signal converters + 3.2 kg / 7.05 lb

- ① F1R - single reduction
 ② F2R - double reduction

Dimensions of flange version ASME B16.5

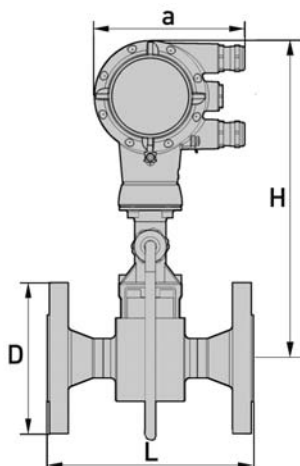

a = 148.5 mm / 5.85"

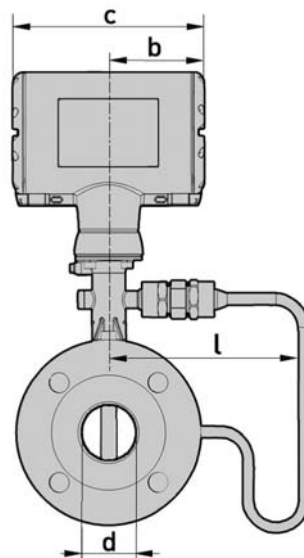

b = 85.8 mm / 3.38"
c = 171.5 mm / 6.76"

Dimensions of flange version ASME B16.5 [mm]

Nominal size DN	Pressure rating Class	d	D	L	H	H F1R ①	H F2R ②	l	l F1R ①	l F2R ②
1/2	150	16	90	200	358.8	-	-	169.3	-	-
1/2	300	16	95	200	358.8	-	-	169.3	-	-
1/2	600	16	95	200	358.8	-	-	169.3	-	-
1	150	26.6	110	200	358.3	358.8	-	169.3	169.3	-
1	300	26.6	125	200	358.3	358.8	-	169.3	169.3	-
1	600	24	125	200	358.3	358.8	-	169.3	169.3	-
1 1/2	150	41	125	200	362.3	358.3	358.8	169.5	169.3	169.3
1 1/2	300	41	155	200	362.3	358.3	358.8	169.5	169.3	169.3
1 1/2	600	41	155	200	362.3	358.3	358.8	169.5	169.3	169.3
2	150	52.5	150	200	368.3	362.3	358.3	169.5	169.5	169.3
2	300	52.5	165	200	368.3	362.3	358.3	169.5	169.5	169.3
2	600	49.2	165	200	368.3	362.3	358.3	169.5	169.5	169.3
3	150	77.9	190	200	380.3	368.3	362.3	169.3	169.5	169.5
3	300	77.9	210	200	380.3	368.3	362.3	169.3	169.5	169.5
3	600	74.0	210	200	380.3	368.3	362.3	169.3	169.5	169.5
4	150	102.3	230	250	396.8	380.3	368.3	171.5	169.3	169.5
4	300	102.3	255	250	396.8	380.3	368.3	171.5	169.3	169.5
4	600	97.0	275	250	396.8	380.3	368.3	171.5	169.3	169.5
6	150	154.1	280	300	416.3	396.8	380.3	191.5	171.5	169.3
6	300	154.1	320	300	416.3	396.8	380.3	191.5	171.5	169.3
6	600	146.0	355	300	416.3	396.8	380.3	191.5	171.5	169.3

Nominal size DN	Pressure rating Class	d	D	L	H	H F1R ①	H F2R ②	l	l F1R ①	l F2R ②
8	150	202.7	345	300	442.1	416.3	396.8	202.8	191.5	171.5
8	300	202.7	380	300	442.1	416.3	396.8	202.8	191.5	171.5
10	150	254.6	405	380	468.8	442.1	416.3	229.5	202.8	191.5
10	300	254.6	455	380	468.8	442.1	416.3	229.5	202.8	191.5
12	150	300.0	485	450	492.8	468.8	442.1	255.0	229.5	202.8
12	300	300.0	520	450	492.8	468.8	442.1	255.0	229.5	202.8

① F1R - single reduction

② F2R - double reduction

Weight of flange version ASME B16.5 [kg]

Nominal size DN	Pressure rating Class	with	without	F1R with	F1R without	F2R with	F2R without
		Pressure sensor		Pressure sensor		Pressure sensor	
1/2	150	5.1	4.5	-	-	-	-
1/2	300	5.5	4.9	-	-	-	-
1/2	600	5.7	5.1	-	-	-	-
1	150	6.8	6.2	6.6	6.0	-	-
1	300	7.8	7.2	7.6	7.0	-	-
1	600	8.1	7.5	7.9	7.3	-	-
1 1/2	150	8.9	8.3	8.6	8.0	7.7	7.1
1 1/2	300	11.0	10.4	10.9	10.3	10.0	9.4
1 1/2	600	12.0	11.4	11.8	11.2	11.0	10.4
2	150	11.6	11.0	11.0	10.4	10.3	9.7
2	300	13.0	12.4	12.6	12.0	11.9	11.3
2	600	14.5	13.9	14.0	13.4	13.4	12.8
3	150	20.4	19.8	16.9	16.3	15.6	15.0
3	300	23.4	22.8	20.4	19.8	19.2	18.6
3	600	24.4	23.8	22.9	22.3	21.8	21.2
4	150	24.0	23.4	25.3	24.7	22.7	22.1
4	300	32.0	31.4	33.9	33.3	31.2	30.6
4	600	41.0	40.4	44.1	43.5	41.2	40.6
6	150	36.8	36.2	37.8	37.2	36.9	36.3
6	300	51.8	51.2	56.1	55.5	55.8	55.2
6	600	76.8	76.2	79.8	79.2	82.6	82.0
8	150	50.6	50.0	48.8	48.2	52.5	51.9
8	300	75.4	74.8	72.2	71.6	78.1	77.5
10	150	75.0	74.4	75.2	74.6	73.9	73.3
10	300	107.0	106.4	112.4	111.8	113.5	112.9
12	150	107.0	106.4	109.8	109.2	120.4	119.8
12	300	152.0	151.4	165.4	155.8	171.7	171.1

Dimensions of flange version ASME B16.5 [inch]

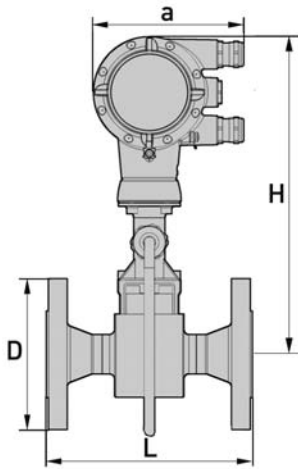

a = 148.5 mm / 5.85"

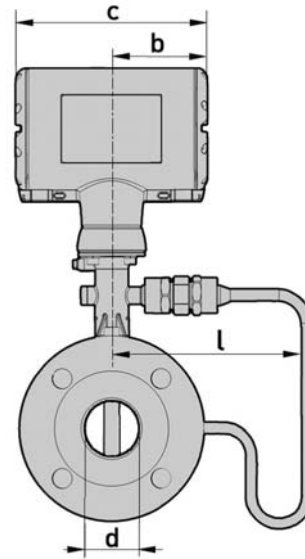

b = 85.8 mm / 3.38"
c = 171.5 mm / 6.76"

Dimensions of flange version ASME B16.5 [inch]

Nominal size DN	Pressure rating Class	d	D	L	H	H F1R ①	H F2R ②	l	l F1R ①	l F2R ②
1/2	150	0.63	3.5	7.9	14.1	-	-	6.67	-	-
1/2	300	0.63	3.7	7.9	14.1	-	-	6.67	-	-
1/2	600	0.63	3.7	7.9	14.1	-	-	6.67	-	-
1	150	1.05	4.3	7.9	14.1	14.1	-	6.67	6.67	-
1	300	1.05	4.9	7.9	14.1	14.1	-	6.67	6.67	-
1	600	1.0	4.9	7.9	14.1	14.1	-	6.67	6.67	-
1 1/2	150	1.6	4.9	7.9	14.3	14.1	14.1	6.67	6.67	6.67
1 1/2	300	1.6	6.1	7.9	14.3	14.1	14.1	6.67	6.67	6.67
1 1/2	600	1.6	6.1	7.9	14.3	14.1	14.1	6.67	6.67	6.67
2	150	2.07	5.9	7.9	14.5	14.3	14.1	6.67	6.67	6.67
2	300	2.07	6.5	7.9	14.5	14.3	14.1	6.67	6.67	6.67
2	600	1.9	6.5	7.9	14.5	14.3	14.1	6.67	6.67	6.67
3	150	3.07	7.5	7.9	15.0	14.5	14.3	6.67	6.67	6.67
3	300	3.07	8.3	7.9	15.0	14.5	14.3	6.67	6.67	6.67
3	600	2.9	8.3	7.9	15.0	14.5	14.3	6.67	6.67	6.67
4	150	4.0	9.1	9.8	15.6	15.0	14.5	6.76	6.67	6.67
4	300	4.0	10	9.8	15.6	15.0	14.5	6.76	6.67	6.67
4	600	3.8	11	9.8	15.6	15.0	14.5	6.76	6.67	6.67
6	150	6.1	11	12	16.4	15.6	15.0	7.54	6.76	6.67
6	300	6.1	13	12	16.4	15.6	15.0	7.54	6.76	6.67
6	600	5.8	14	12	16.4	15.6	15.0	7.54	6.76	6.67

Nominal size DN	Pressure rating Class	d	D	L	H	H F1R ①	H F2R ②	l	l F1R ①	l F2R ②
8	150	8.0	14	12	17.4	16.4	15.6	8.0	7.54	6.76
8	300	8.0	15	12	17.4	16.4	15.6	8.0	7.54	6.76
10	150	10	16	15	18.5	17.4	16.4	9.04	8.0	7.54
10	300	10	18	15	18.5	17.4	16.4	9.04	8.0	7.54
12	150	12	19	18	19.4	18.5	17.4	10.0	9.04	8.0
12	300	12	21	18	19.4	18.5	17.4	10.0	9.04	8.0

① F1R - single reduction

② F2R - double reduction

Weight of flange version ASME B16.5 [lb]

Nominal size DN	Pressure rating Class	with	without	F1R with	F1R without	F2R with	F2R without
		Pressure sensor		Pressure sensor		Pressure sensor	
1/2	150	11	9.9	-	-	-	-
1/2	300	12	11	-	-	-	-
1/2	600	13	11	-	-	-	-
1	150	15	14	14.6	13.2	-	-
1	300	17	16	16.8	15.4	-	-
1	600	18	17	17.4	16.1	-	-
1 1/2	150	20	18	19.0	17.6	17.0	15.7
1 1/2	300	24.3	22.9	24.0	22.7	22.1	20.7
1 1/2	600	26.5	25.1	26.0	24.7	24.1	22.9
2	150	25.6	24.3	24.3	22.9	22.7	21.4
2	300	28.7	27.3	27.8	26.5	26.2	24.9
2	600	32.0	30.7	30.9	29.6	29.6	28.2
3	150	45.0	43.7	37.3	36.0	34.4	33.1
3	300	51.6	50.3	45.0	43.7	42.3	41.0
3	600	53.8	52.5	50.5	49.2	48.1	46.8
4	150	52.9	51.6	55.8	54.5	50.1	48.7
4	300	70.6	69.3	74.8	73.4	68.8	67.5
4	600	90.4	89.1	97.3	95.9	91.0	89.5
6	150	81.2	79.8	83.4	82.0	81.4	80.0
6	300	114.2	112.9	123.7	122.4	123.1	121.7
6	600	169.4	168.1	176	174.7	182.2	181.0
8	150	111.6	110.3	107.6	106.3	115.8	114.5
8	300	166.3	165.0	159.2	157.9	172.2	171.0
10	150	165.4	164.1	165.9	164.5	163.0	161.7
10	300	236.0	234.7	247.9	246.6	250.3	249.0
12	150	236.0	234.7	242.2	240.8	265.5	264.2
12	300	335.2	333.9	364.8	343.6	378.7	377.4

8.3.2 Sandwich version

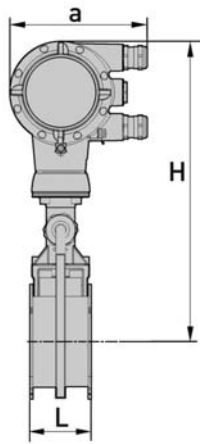

a = 133 mm / 5.24"

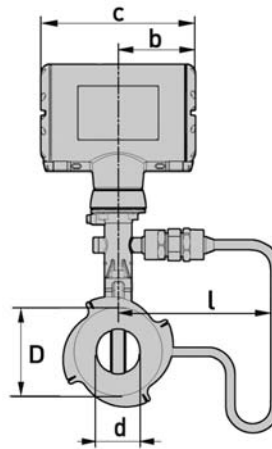

b = 105 mm / 4.13"
c = 179 mm / 7.05"

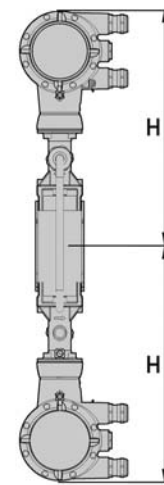

Dimension H x 2
Specified weight: + 2.8 kg / 6.2 lb

Sandwich version EN

Nominal size DN	Pressure rating PN	Dimensions [mm]					Weight [kg]	
		d	D	L	H	l	with	without
15	100	16	45	65	358.8	169.3	4.1	3.5
25	100	24	65	65	358.3	169.3	4.9	4.3
40	100	38	82	65	362.3	169.5	5.5	4.9
50	100	50	102	65	368.3	169.5	6.6	6.0
80	100	74	135	65	380.3	169.3	8.8	8.2
100	100	97	158	65	396.8	171.5	10.1	9.5

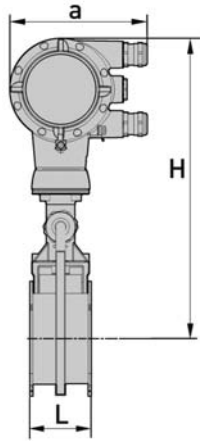

a = 133 mm / 5.24"

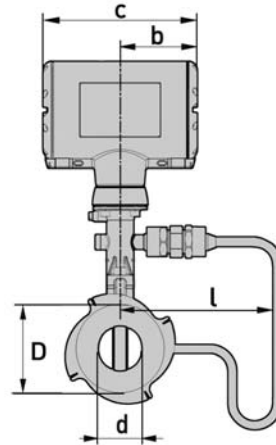

b = 105 mm / 4.13"
c = 179 mm / 7.05"

Sandwich version ASME

Nominal size NPS	Pressure rating Class	Dimensions [inch]					Weight [lb]	
		d	D	L	H	l	with	without
							Pressure sensor	
1/2	150	0.63	1.77	2.56	14.13	6.67	9.04	7.72
1/2	300	0.63	1.77	2.56	14.13	6.67	9.04	7.72
1/2	600	0.55	1.77	2.56	14.13	6.67	9.04	7.72
1	150	0.94	2.56	2.56	14.13	6.67	10.8	9.48
1	300	0.94	2.56	2.56	14.13	6.67	10.8	9.48
1	600	0.94	2.56	2.56	14.13	6.67	10.8	9.48
1 1/2	150	1.5	3.23	2.56	14.27	6.67	12.13	10.8
1 1/2	300	1.5	3.23	2.56	14.27	6.67	12.13	10.8
1 1/2	600	1.5	3.23	2.56	14.27	6.67	12.13	10.8
2	150	1.97	4.02	2.56	14.50	6.67	14.55	13.23
2	300	1.97	4.02	2.56	14.50	6.67	14.55	13.23
2	600	1.97	4.02	2.56	14.50	6.67	14.55	13.23
3	150	2.91	5.31	2.56	14.98	6.67	19.4	18.08
3	300	2.91	5.31	2.56	14.98	6.67	19.4	18.08
3	600	2.91	5.31	2.56	14.98	6.67	19.4	18.08
4	150	3.82	6.22	2.56	15.63	6.75	22.27	20.94
4	300	3.82	6.22	2.56	15.63	6.75	22.27	20.94
4	600	3.82	6.22	2.56	15.63	6.75	22.27	20.94

8.3.3 Dimensions of remote version

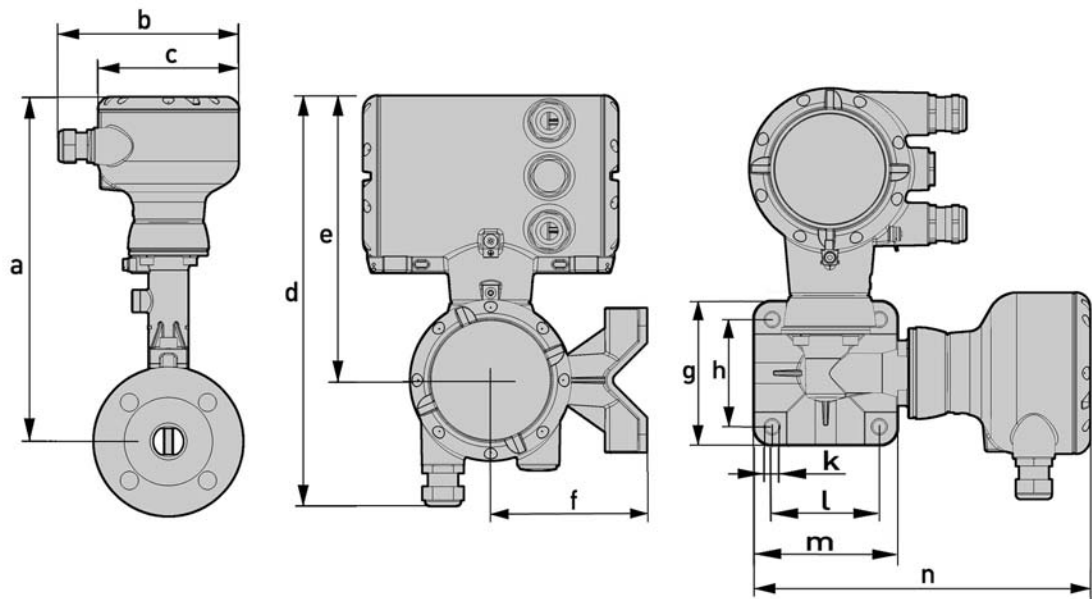

Dimension a

	Flange & sandwich version						Flange version			
DN ▶	15	25	40	50	80	100	150	200	250	300
NPS ▶	1/2	1	1 1/2	2	3	4	6	8	10	12
[mm] ▶	315.7	315.2	319.2	325.2	337.2	353.7	373.2	398.9	425.7	449.7
["] ▶	12.4	12.4	12.6	12.8	13.3	13.9	14.7	15.7	16.8	17.7

Dimension a F1/2R

	Flange version									
DN ▶	15	25	40	50	80	100	150	200	250	300
NPS ▶	1/2	1	1 1/2	2	3	4	6	8	10	12
F1R ① [mm] ▶	-	315.7	315.2	319.2	325.2	337.2	353.7	373.2	398.9	425.7
F1R ① ["] ▶	-	12.4	12.4	12.6	12.8	13.3	13.9	14.7	15.7	16.8
F2R ② [mm] ▶	-	-	315.7	315.2	319.2	325.2	337.2	353.7	373.2	398.9
F2R ② ["] ▶	-	-	12.4	12.4	12.6	12.8	13.3	13.9	14.7	15.7

① F1R - single reduction - ② F2R - double reduction

Dimensions b...n

	b	c	d	e	f	g	h	j	k	l	m	n
[mm]	138.5	108.0	275.6	191.2	105.0	97.0	72.0	108.0	9.0	72.0	97.0	226.0
["]	5.46	4.25	10.9	7.53	4.14	3.82	2.84	4.25	0.35	2.84	3.82	8.90

8.4 Flow tables

Measuring ranges

Nominal size		Q_{\min}	Q_{\max}	Q_{\min}	Q_{\max}
DN - EN 1092-1	NPS - ASME B16.5	[m ³ /h]		[gph]	

Water

15	3/8	0.36	5.07	95.61	1339
25	1	0.81	11.40	215	3012
40	1 1/2	2.04	28.58	539	7550
50	2	3.53	49.48	934	13072
80	3	7.74	108.3	2045	28632
100	4	13.30	186.2	3514	49196
150	6	30.13	421.89	7961	111454
200	8	56.61	792.5	14954	209356
250	10	90.49	1267	23905	334681
300	12	131.4	1840	34720	486077

Values based on water at +20°C / +68°F

Air

15	3/8	4.34	32.57	1147	8605
25	1	9.77	114.0	2581	30117
40	1 1/2	24.50	326.6	6472	86288
50	2	42.41	565.5	11204	149390
80	3	92.90	1239	24542	327224
100	4	159.6	2128	42168	562245
150	6	361.6	4822	95532	1273761
200	8	679.3	9057	179448	2392635
250	10	1086	14478	286870	3824929
300	12	1577	21028	416638	5555167

Values based on air at +20°C / +68°F and 1.013 bara / 14.7 psia and density 1.204 kg/m³ / 0.0751 lb/ft³

Measuring range saturated steam: 1...7 barg

Gauge pressure [barg]		1		3.5		5.2		7	
Density [kg/m ³]		1.134		2.419		3.272		4.166	
Temperature [°C]		120.4		148.0		160.2		170.5	
Flow rate		min	max	min	max	min	max	min	max
DN EN 1092-1	NPS ASME B16.5	[kg/h]		[kg/h]		[kg/h]		[kg/h]	
15	3/8	5.07	36.94	7.41	78.8	8.62	106.6	9.73	135.7
25	1	11.42	129.3	16.68	275.8	19.40	373.0	21.88	474.9
40	1 1/2	28.63	370.4	41.87	790.3	48.62	1069	54.86	1361
50	2	49.56	641.3	72.39	1368	84.18	1850	94.98	2356
80	3	108.6	1405	158.6	2997	184.4	4053	208.1	5160
100	4	186.5	2414	272.4	5149	316.8	6964	357.5	8866
150	6	422.6	5468	617.2	11666	717.8	15777	809.9	20086
200	8	793.7	10271	1159	21913	1348	29636	1521	37730
250	10	1269	16420	1853	35031	2155	47376	2432	60316
300	12	1843	23848	2692	50877	3130	68807	3532	87601

Measuring range saturated steam: 10.5...20 barg

Gauge pressure [barg]		10.5		14		17.5		20	
Density [kg/m ³]		5.883		7.588		9.304		10.53	
Temperature [°C]		186.1		198.3		208.5		214.9	
Flow rate		min	max	min	max	min	max	min	max
DN EN 1092-1	NPS ASME B16.5	[kg/h]		[kg/h]		[kg/h]		[kg/h]	[kg/h]
15	3/8	12.77	191.6	16.48	247.2	20.20	303.1	22.87	343.1
25	1	26.01	670.6	29.54	857.0	32.71	954.8	34.80	1020
40	1 1/2	66.19	1877	74.05	2148	81.99	2394	87.24	2556
50	2	112.9	3250	128.2	3720	142.0	4144	151.0	4426
80	3	247.2	7119	280.8	8148	310.9	9077	330.8	9694
100	4	424.8	12232	482.5	13999	534.2	15597	568.5	16657
150	6	962.4	27712	1093	31715	1210	35334	1288	37737
200	8	1808	52054	2053	59574	2273	66371	2419	70884
250	10	2890	83215	3282	95237	3634	106102	3867	113318
300	12	4197	120858	4767	138318	5279	154099	5617	164578

Measuring range saturated steam: 15...100 psig

Gauge pressure [psig]		15		50		75		100	
Density [lb/ft ³]		0.0721		0.1496		0.2033		0.2564	
Temperature [°F]		249.8		297.7		320.0		337.8	
Flow rate		min	max	min	max	min	max	min	max
DN EN 1092-1	NPS ASME B16.5	[lb/h]		[lb/h]		[lb/h]		[lb/h]	[lb/h]
15	3/8	11.09	81.44	16.42	173.7	19.05	235.0	21.59	299.2
25	1	24.95	285.0	36.95	608.1	42.86	822.4	48.58	1047
40	1 1/2	62.55	816.7	92.63	1742	107.5	2356	121.8	3000
50	2	108.3	1414	160.4	3016	186.0	4079	210.9	5194
80	3	237.2	3097	351.3	6607	407.5	8935	461.9	11376
100	4	407.6	5321	603.6	11352	700.1	15353	793.6	19547
150	6	923.3	12055	1367	25719	1586	34782	1798	44283
200	8	1734	22645	2569	48310	2979	65335	3377	83180
250	10	2773	36200	4106	77230	4763	104447	5399	132974
300	12	4027	52576	5964	112165	6918	151694	7841	193127

Measuring range saturated steam: 150...300 psig

Gauge pressure [psig]		150		200		250		300	
Density [lb/ft ³]		0.3626		0.4682		0.5727		0.6781	
Temperature [°F]		365.9		387.9		406.0		421.7	
Flow rate		min	max	min	max	min	max	min	max
DN EN 1092-1	NPS ASME B16.5	[lb/h]		[lb/h]		[lb/h]		[lb/h]	[lb/h]
15	3/8	28.16	422.4	36.33	544.9	44.54	668.1	50.43	756.4
25	1	57.70	1479	65.50	1900	72.61	2119	75.64	2216
40	1 1/2	144.7	4164	164.2	4763	182.0	5312	189.6	5555
50	2	250.4	7209	284.3	8246	315.2	9197	328.3	96.18
80	3	548.6	15790	622.7	18062	690.3	20145	719.1	21067
100	4	942.5	27131	1070	31035	1186	34614	1236	36198
150	6	2135	61464	2424	70309	2687	78419	2799	82006
200	8	4011	115455	4553	132068	5048	147302	5258	154041
250	10	6412	184569	7279	211127	8069	235481	8406	246254
300	12	9313	268060	10571	306632	11720	342002	12209	357649









KROHNE – Process instrumentation and measurement solutions

- Flow
- Level
- Temperature
- Pressure
- Process Analysis
- Services

Head Office KROHNE Messtechnik GmbH
Ludwig-Krohne-Str. 5
47058 Duisburg (Germany)
Tel.: +49 203 301 0
Fax: +49 203 301 10389
info@krohne.com

The current list of all KROHNE contacts and addresses can be found at:
www.krohne.com

KROHNE