

# Model 10 General Purpose pH Sensor

## Features

- Select pH or ORP Measurement
- Temperature Compensation Pt100 or Pt1000
- Non-fouling Porous<sup>1</sup> Teflon<sup>®</sup> Liquid Junction
- Large Volume Reference Electrolyte Reservoir
- Compact Design
- 1/2" MNPT Process Connections
- Designed for Flow Through and Submersion Applications
- Suitable for High Temperature Use



## Applications

- Potable Water
- Cooling Towers
- Surface Water Monitoring
- Fresh and Salt Water Aquariums
- Fish Farming
- Hydroponics

## Description

**Model 10 pH Sensor** is designed for use in general purpose water applications. The large volume single junction reference cell coupled with the non-fouling porous Teflon<sup>®</sup> liquid junction assures a long life in general service.

## Specifications

Body Material	Ryton <sup>®</sup>
O-Rings	Viton <sup>®</sup>
Measuring Range	0 to 14 pH
Temperature Range	-5 to 80°C (23 to 176°F) Standard Version 25 to 110°C (77 to 230°F) High Temp Version
Pressure Range	0 to 6.9 bar (0 to 100 psig)
Drift	< 2.0 mV/week
Response Time @ 25°C (77°F)	95% of reading in 10 seconds
pH Glass Bulb Impedance @ 25°C (77°F)	80 Megohms (Standard Version) 150 Megohms (High Temp Version)

<sup>®</sup>Teflon and Viton are Registered Trademarks of E.I. Dupont de Nemours Company

<sup>®</sup> Ryton is a registered trademark of Philips 66 Co.

# Model 10 General Purpose pH Sensor

## Ordering Information

Model 10	Description
M-10	General Purpose pH Sensor with Protective Guard Single Junction Reference Cell No Temperature Compensation Process Connections 1/2" MNPT Insertion Length 16.5mm (0.65") 3.3m (10 ft.) Cable with BNC
Measurement Options	Description
ORP	Platinum ORP Electrode
HT	For continuous high temperature use >80°C (176°F)
Temperature Compensation	Description
PT100	Temperature Compensation, 100 Ohm RTD
PT1000	Temperature Compensation, 1000 Ohm RTD
3KTC	Temperature Compensation, 3000 Ohm Thermistor
<b>M-10-PT100</b>	<b>Example Order Number</b>

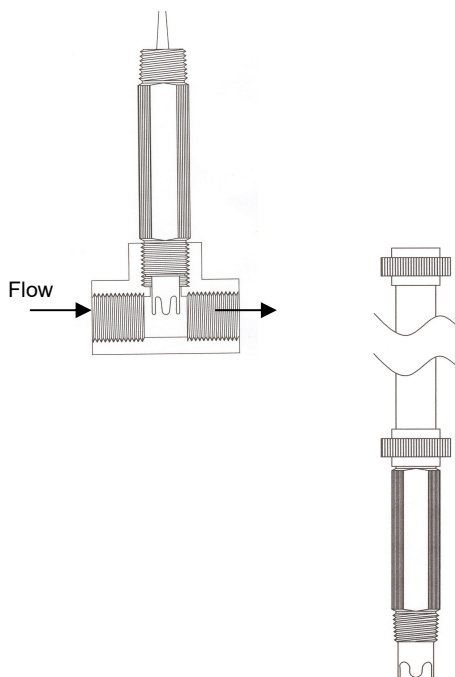
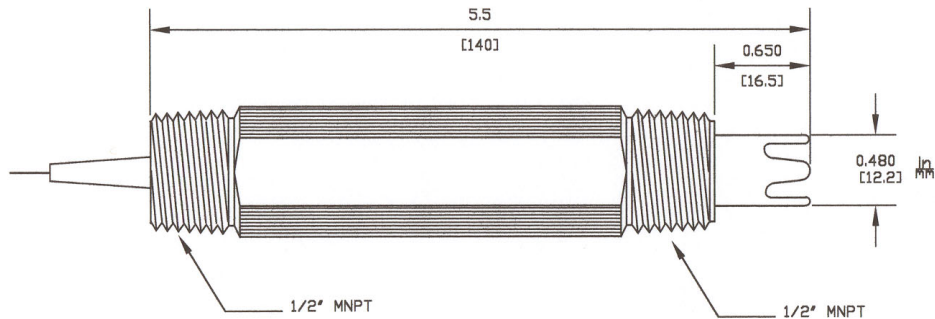

### Flow Installation:

- 1/2" NPT Pipe Tee (supplied by other source)
- Use Teflon® Tape on sensor to permit removal for routine maintenance
- Install shut off valves upstream and downstream of sensor
- Optimum flow rate is 3 to 5 GPM
- Sensor must remain in solution at all times

### Submersion Installation:

- 1/2" Submersion pipe (supplied by other source)
- Attach sensor to pipe with 1/2" union (supplied by other source)
- Use Teflon® tape on sensor to permit removal for routine maintenance
- Sensor must remain in solution at all times

Note: Variations in design of plastic plumbing parts from different manufacturers can be expected. Check tolerances prior to installation.