

# Technical Information

## OCUS50D

Absorption sensor for turbidity and solids measurements



### Application

Turbimax CUS50D is an absorption sensor for measuring turbidity or solids content. The sensor ensures reliable measurements and efficient process monitoring, even in aggressive media:

- Industrial wastewater and utilities:
  - Measurement of solids content in process sludges and wastewater sludges
  - Flocculant dosing
  - Measurement of concentration of dairy products in wastewater
- Process media:  
Concentration measurement in the product, e.g. in titanium dioxide
- Highly absorptive media:  
Concentration measurement in very dark media, e.g. activated carbon concentration in the 4th treatment step of wastewater treatment plants

### Your benefits

- Turbidity measurement according to the principle of light attenuation as per ISO7027
- Glass-free, non-adhesive sensor head with 2 path lengths (5 mm and 10 mm)
- Standardized communication (Memosens technology) enables "plug and play"
- Sensor head made of a PTFE derivative is easy to keep clean using the air cleaning unit
- Long service life of sensor thanks to resistant materials used in sensor shaft and head  
Sensor is precalibrated ex works and includes different application models
- Automatic sludge model independently selects the optimum signal characteristics for each type of sludge
- 1-point calibration suffices in most applications



## Table of contents

<b>Function and system design.....</b>	<b>4</b>	Compressed air cleaning.....	18
Measuring principle .....	4	Calibration kit.....	18
Measuring system .....	4		
Sensor monitoring.....	5		
Applications.....	5		
<b>Input .....</b>	<b>6</b>		
Measured variable.....	6		
Measuring range.....	6		
<b>Power supply .....</b>	<b>6</b>		
Electrical connection.....	6		
<b>Performance characteristics.....</b>	<b>9</b>		
Reference operating conditions.....	9		
Maximum measured error.....	9		
Repeatability.....	9		
Drift.....	9		
Detection limits .....	9		
<b>Installation .....</b>	<b>10</b>		
Orientation .....	10		
<b>Environment.....</b>	<b>13</b>		
Ambient temperature range.....	13		
Storage temperature .....	13		
Degree of protection.....	13		
Electromagnetic compatibility (EMC) .....	13		
<b>Process.....</b>	<b>13</b>		
Process temperature range.....	13		
Process pressure range .....	13		
Minimum flow.....	13		
<b>Mechanical construction .....</b>	<b>14</b>		
Dimensions .....	14		
Weight .....	15		
Materials.....	15		
Process connections .....	15		
<b>Certificates and approvals.....</b>	<b>16</b>		
CE mark.....	16		
Electromagnetic compatibility.....	16		
ISO 7027 .....	16		
EAC .....	16		
Marine approvals .....	16		
<b>Ordering information .....</b>	<b>16</b>		
Product Configurator .....	16		
Scope of delivery.....	16		
<b>Accessories .....</b>	<b>16</b>		
Assemblies.....	16		
Holder .....	17		
Mounting material.....	17		

## Function and system design

### Measuring principle

The sensor operates on the principle of light attenuation and meets the requirements of turbidity measurement according to the principle of light attenuation as per ISO 7027. The measurement is performed with a wavelength of 860 nm.

It is suitable for measurements in the average to high turbidity range and for the measurement of solids content.

### Measuring system

A complete measuring system comprises:

- OCUS50D turbidity sensor
- OCM44x multi-channel transmitter
- Direct installation in a pipe connection (Clamp 2") or
- Assembly:
  - Flow assembly e.g. Flowfit CUA252 or CUA120 or
  - Assembly e.g. Flexdip CYA112 and holder e.g. Flexdip CYH112 or
  - Retractable assembly, e.g. Cleanfit CUA451

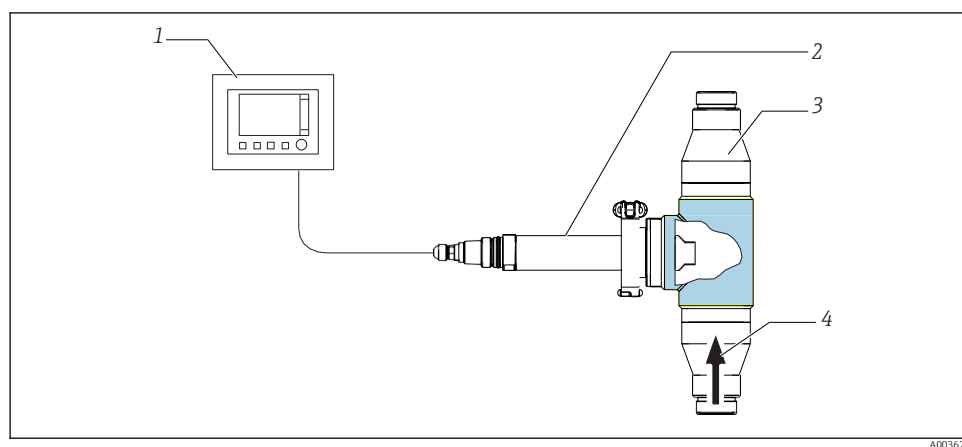

1 Measuring system with CUA252 flow assembly

- 1 OCM44x multi-channel transmitter
- 2 OCUS50D turbidity sensor
- 3 CUA252 flow assembly
- 4 Direction of flow

### Sensor structure

The sensor features a sensor head with 2 path lengths of 5 mm (0.2 in) and 10 mm (0.39 in).

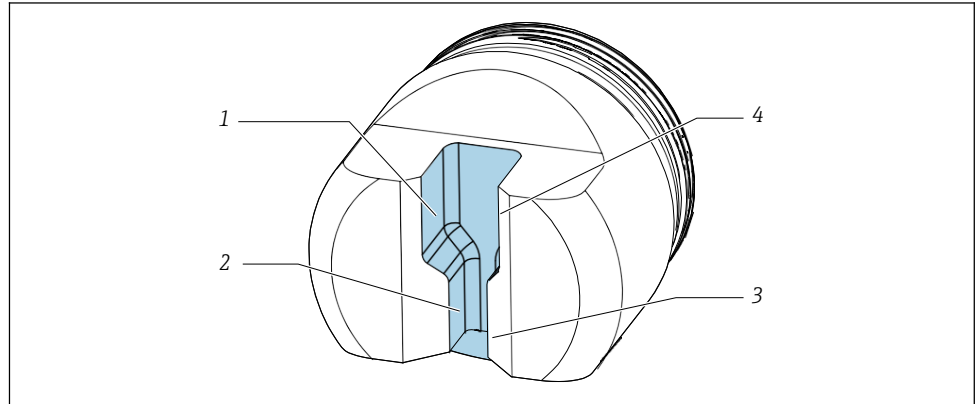

A0036825

2 OCUS50D sensor head

- 1 Light sources 10 mm (0.39 in)
- 2 Light sources 5 mm (0.2 in)
- 3 Light receiver 5 mm (0.2 in)
- 4 Light receiver 10 mm (0.39 in)

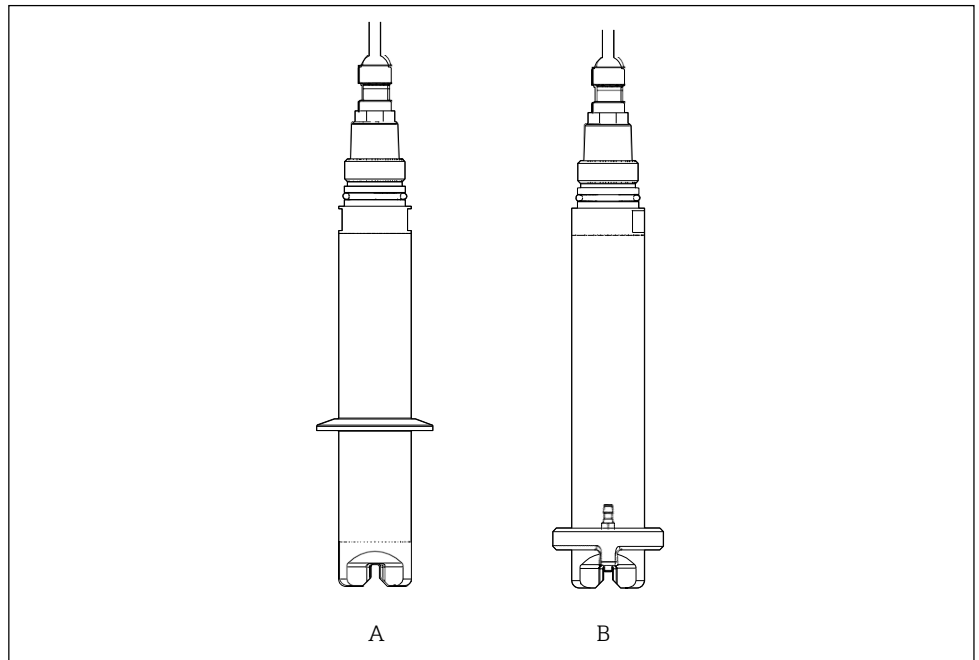

A0036368

3 Versions

- A With clamp
- B With compressed air cleaning

**Sensor monitoring**

The optical signals are continuously monitored and analyzed for plausibility. If inconsistencies occur, an error message is output via the transmitter. The function is disabled by default.

**Applications**

The "Absorption" and "Formazine" applications are calibrated at the factory. The absorption factory calibration is used as the basis for precalibrating additional applications and optimizing them for the different media characteristics.

Application	Specified operating range
Factory calibration for absorption	0.000 to 5.000 AU or 0.000 to 10.000 OD
Factory calibration for formazine	40 to 4,000 FAU

Application	Specified operating range
Application: Kaolin	0 to 60 g/l
Application: Sludge	0 to 25 g/l
Application: Auto sludge	0 to 25 g/l
Product loss	0 to 100 %

To adapt to a specific application, it is possible to perform customer calibrations with up to 10 points.

#### Application: Formazine

Factory calibration for the formazine application is carried out with the formazine turbidity standard.

 Sensor measured values in the unit [FAU] are only comparable to the measured values of any other sensor e.g. scattered light sensor with the unit [FNU] or [NTU] in this standard medium. In any other medium, the measured values will be different to those obtained when measuring with another scattered light sensor.

## Input

### Measured variable

- Turbidity
- Absorption
- Solids content
- Product loss
- Temperature

### Measuring range

Application	Specified operating range	Maximum operating range
Absorption factory calibration	0.000 to 5.000 AU or 0.000 to 10.000 OD	
Factory calibration for formazine	40 to 4,000 FAU	10000 FAU
Application: Kaolin	0 to 60 g/l	500 g/l
Application: Sludge	0 to 25 g/l	500 g/l
Application: Auto sludge	0 to 25 g/l	500 g/l
Product loss	0 to 100 %	1000%

 Measuring range with solids content:

For solids, the achievable ranges depend very much on the media that are actually present and may differ from the recommended operating ranges. Extremely inhomogeneous media may cause fluctuations in measured values, thus narrowing the measuring range.

## Power supply

### Electrical connection

- ▶ Connect the sensor to the OCM44 transmitter for operation.

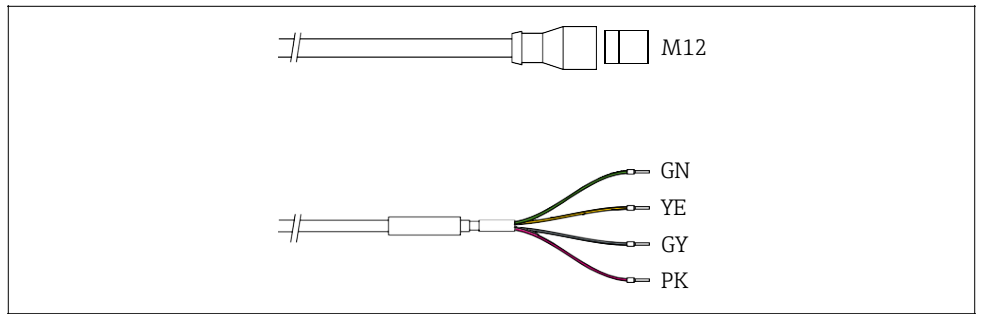

A0036365

4 Connection options

The following connection options are available:

- via M12 connector (version: fixed cable, M12 connector)
- via sensor cable to the plug-in terminals of a sensor input on the transmitter (version: fixed cable, end sleeves)

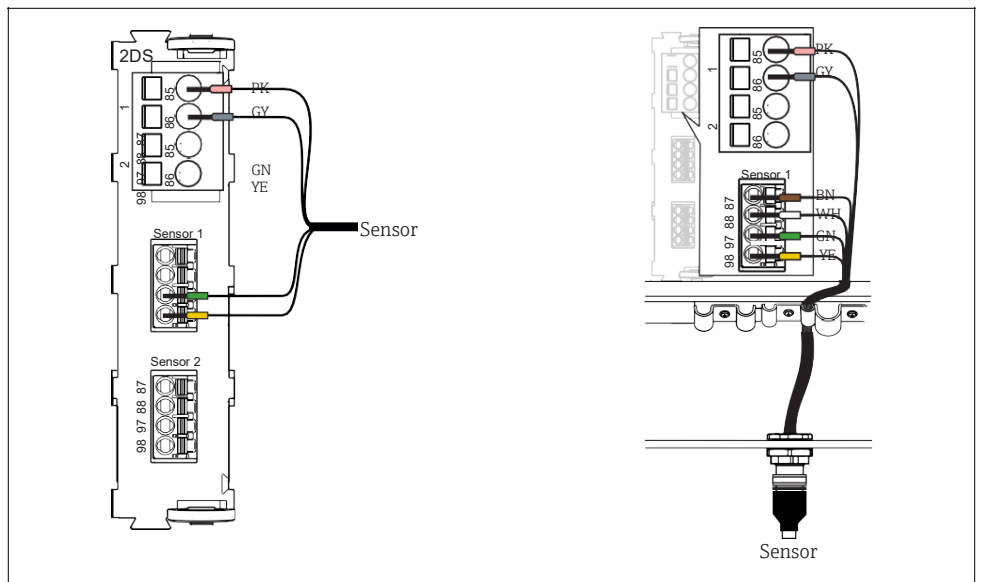

A0033092

5 Sensor connection to sensor input (left) or via M12 connector (right)

### Connecting the cable shield

Cable sample (does not necessarily correspond to the original cable supplied)

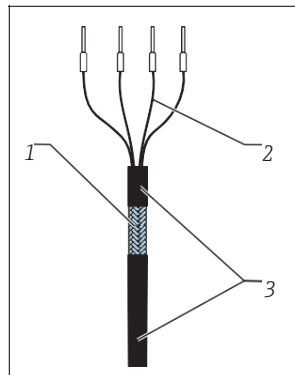

6 Terminated cable

- 1 Outer shield (exposed)
- 2 Cable cores with ferrules
- 3 Cable sheath (insulation)

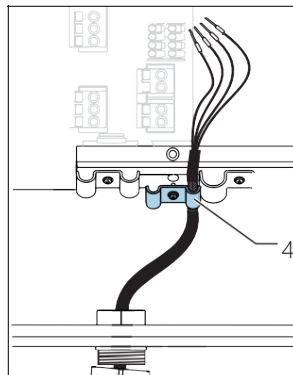

7 Inserting the cable

- 4 Grounding clip

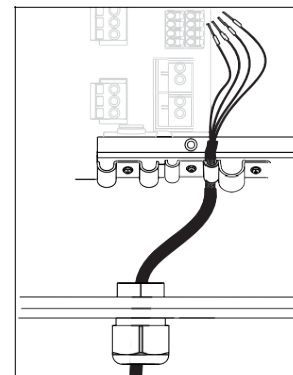

8 Tightening the screw  
(2 Nm (1.5 lbf ft))

The cable shield is grounded by the grounding clip

The maximum cable length is 100 m (328.1 ft).



## Performance characteristics

### Reference operating conditions

20 °C (68 °F), 1013 hPa (15 psi)

### Maximum measured error

Absorption	0.5 % of the upper range value (corresponds to $\pm 50$ mOD)
Formazine	10 % of the measured value or 10 FAU (the greater value applies in each case)
Kaolin	5 % of the upper range value; applies to sensors that are calibrated for the observed measuring range
Sludge/auto sludge	10 % of the measured value or 5 % of the upper range value (the greater value applies in each case); applies to sensors that are calibrated for the observed measuring range
Product loss	Not specified; very much depends on the condition of the measuring medium used

 For solids, the achievable measured errors depend very much on the media that are actually present and may differ from the specified values. Extremely inhomogeneous media cause the measured value to fluctuate and increase the measured error.

 The measured error encompasses all inaccuracies of the measuring chain (sensor and transmitter). However, it does not include the inaccuracy of the reference material used for calibration.

### Repeatability

Application	Repeatability
Absorption	0.001 OD or 0.2% of measured value (the greater value applies in each case)
Formazine	10 FAU for 800 FAU

 For kaolin, sludge/autosludge and product loss, the repeatability depends very much on the media that are actually present. It is therefore not possible to specify general values.

### Drift

Working on the basis of electronic controls, the sensor is largely free of drifts.

- Formazine: drift 0.04% per day (for 2000 FAU)
- Absorption: drift 0.015% per day (for 5 OD)

### Detection limits

Application	Detection limit
Absorption	0.004 OD for 0.5 OD
Formazine	10 FAU

 For kaolin, sludge/autosludge and product loss, the detection limit depends very much on the media that are actually present. It is therefore not possible to specify general values.

## Installation

### Orientation

#### Orientation in pipes

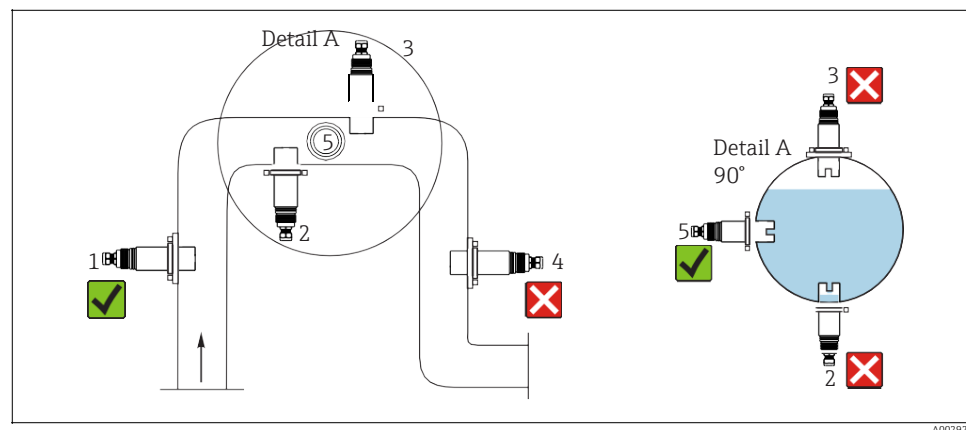

9 Permitted and unacceptable orientations in pipes

- The pipeline diameter must be at least 50 mm (2 in).
- Install the sensor in places with consistent flow conditions.
- The best installation location is in the ascending pipe (item 1).

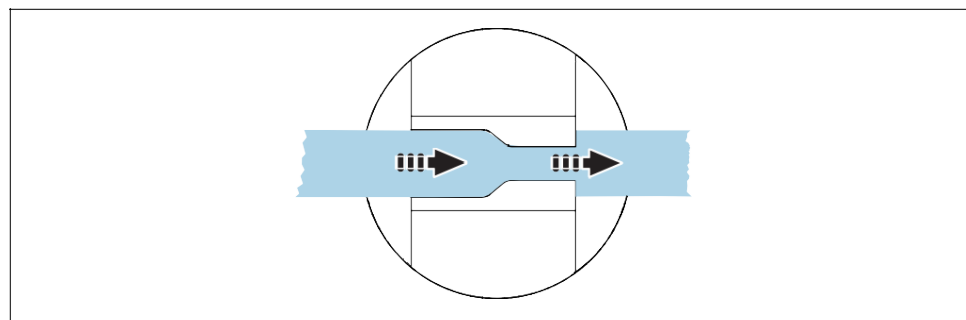

10 Direction of flow

- Align the sensor in such a way that the medium flows through the measuring gap (self-cleaning effect).

The arrow indicates the flow direction; it runs from the 10 mm (0.39 in) path to the 5 mm (0.2 in) path.

#### Installation marking

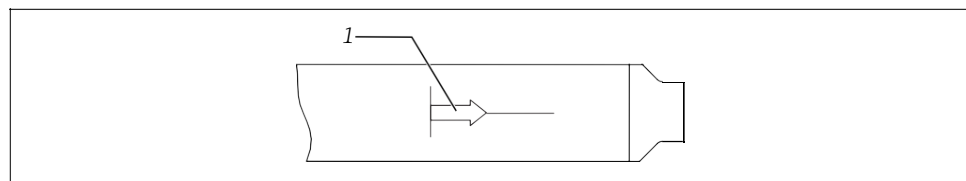

11 Installation marking for sensor alignment

1 Installation marking

The installation marking on the sensor is opposite the optical system.

- Using the installation marking, align the sensor against the flow direction.

**Installation options**

Installation options:

- With flow assembly e.g. Flowfit CUA252 or CUA120
- with retractable assembly, e.g. Cleanfit CUA451
- with assembly e.g. Flexdip CYA112 and holder e.g. Flexdip CYH112

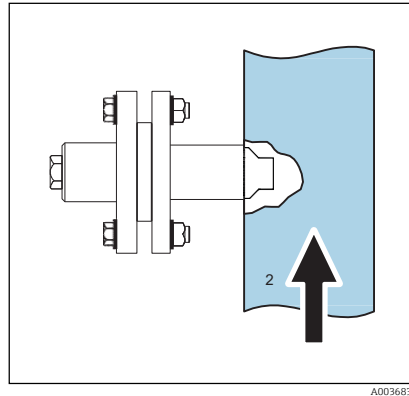

12 Installing with CUA120 flow assembly

The installation angle is 90°.  
The arrow indicates the flow direction; it runs from the 10 mm (0.39 in) path to the 5 mm (0.2 in) path.

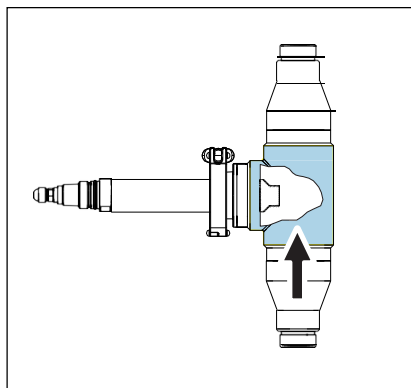

A0036837

13 Installing with CUA252 flow assembly

The installation angle is 90°. The arrow indicates the flow direction; it runs from the 10 mm (0.39 in) path to the 5 mm (0.2 in) path.

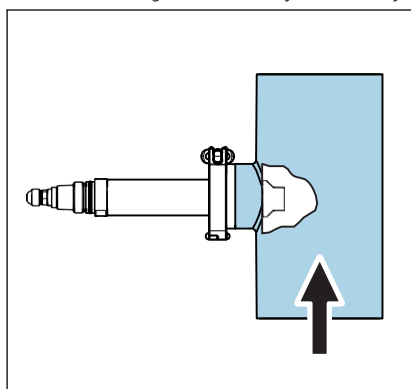

A0036836

14 Installing with CUA262 flow assembly

The installation angle is 90°. The arrow indicates the flow direction; it runs from the 10 mm (0.39 in) path to the 5 mm (0.2 in) path.

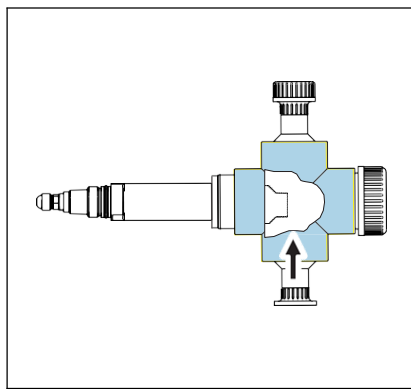

A0041336

15 Installing with CYA251 flow assembly

The installation angle is 90°. The arrow indicates the flow direction; it runs from the 10 mm (0.39 in) path to the 5 mm (0.2 in) path.

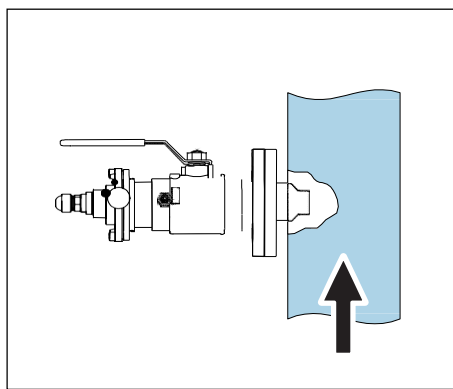

A0036838

16 Installing with CUA451 retractable assembly

The installation angle is 90°. The arrow indicates the flow direction; it runs from the 10 mm (0.39 in) path to the 5 mm (0.2 in) path. The medium pressure may not exceed 2 bar (29 psi) for manual assembly retraction.

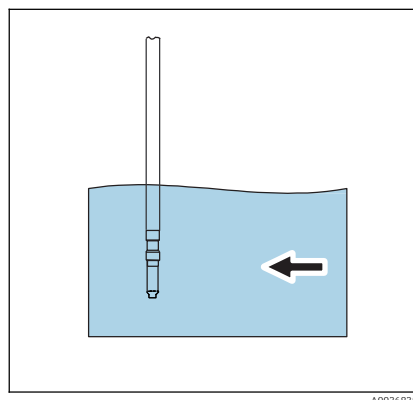

17 Installing with immersion assembly

The installation angle is 0°. The arrow indicates the flow direction; it runs from the 10 mm (0.39 in) path to the 5 mm (0.2 in) path. If the sensor is used in open basins, install the sensor in such a way that air bubbles cannot accumulate on it.

#### Compressed air cleaning

- ▶ Fit the compressed air cleaning unit onto the sensor head to the end stop. The nozzle of the compressed air cleaning unit must be located on the side of the wider 10 mm (0.4 in) measurement gap.

## Environment

<b>Ambient temperature range</b>	-20 to 60 °C (-4 to 140 °F)
<b>Storage temperature</b>	-20 to 70 °C (-4 to 158 °F)
<b>Degree of protection</b>	IP 68 (1.8 m (5.91 ft) water column over 20 days, 1 mol/l KCl)
<b>Electromagnetic compatibility (EMC)</b>	Interference emission and interference immunity as per <ul style="list-style-type: none"> <li>▪ EN 61326-1:2013</li> <li>▪ EN 61326-2-3:2013</li> <li>▪ NAMUR NE21:2012</li> </ul>

## Process

<b>Process temperature range</b>	-20 to 85 °C (-4 to 185 °F)
<b>Process pressure range</b>	0.5 to 4.5 bar (7.3 to 65.3 psi) absolute
<b>Minimum flow</b>	No minimum flow required. <ul style="list-style-type: none"> <li> For solids which have a tendency to form deposits, ensure that sufficient mixing is performed.</li> </ul>

## Mechanical construction

### Dimensions

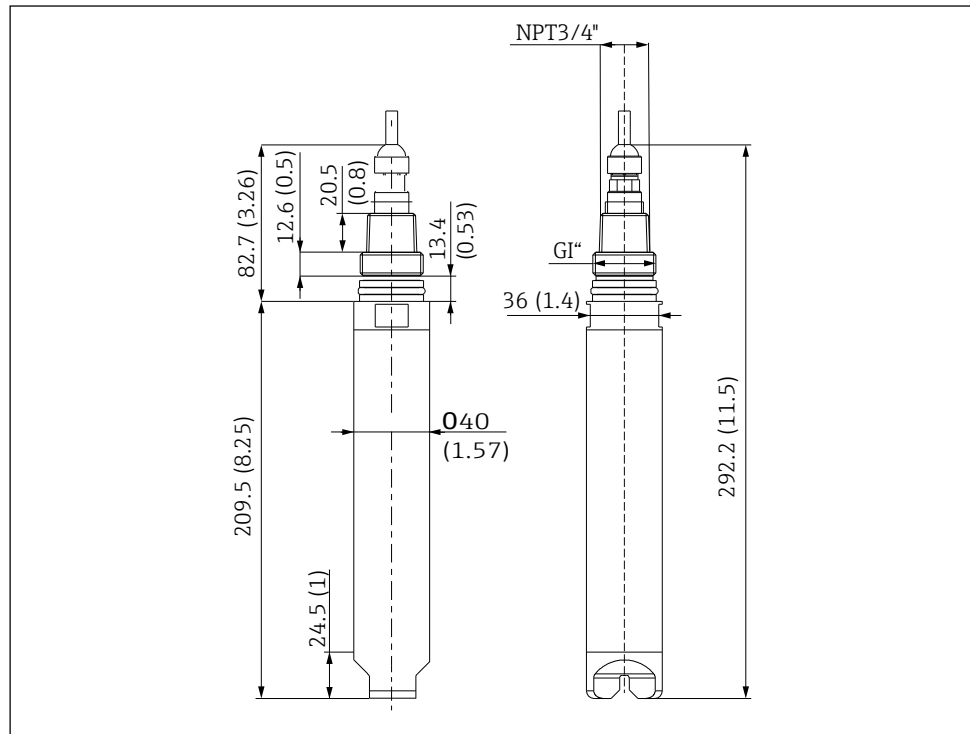

A0036366

18 Dimensions. Dimensions: mm (in)

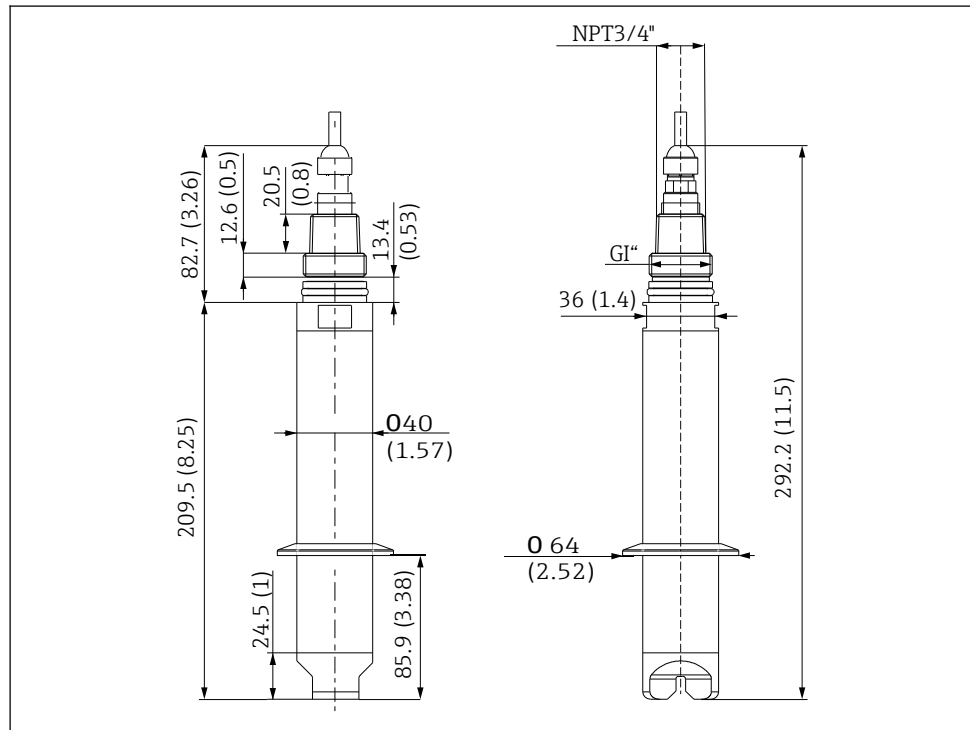

A0036582

19 Dimensions with clamp. Dimensions: mm (in)

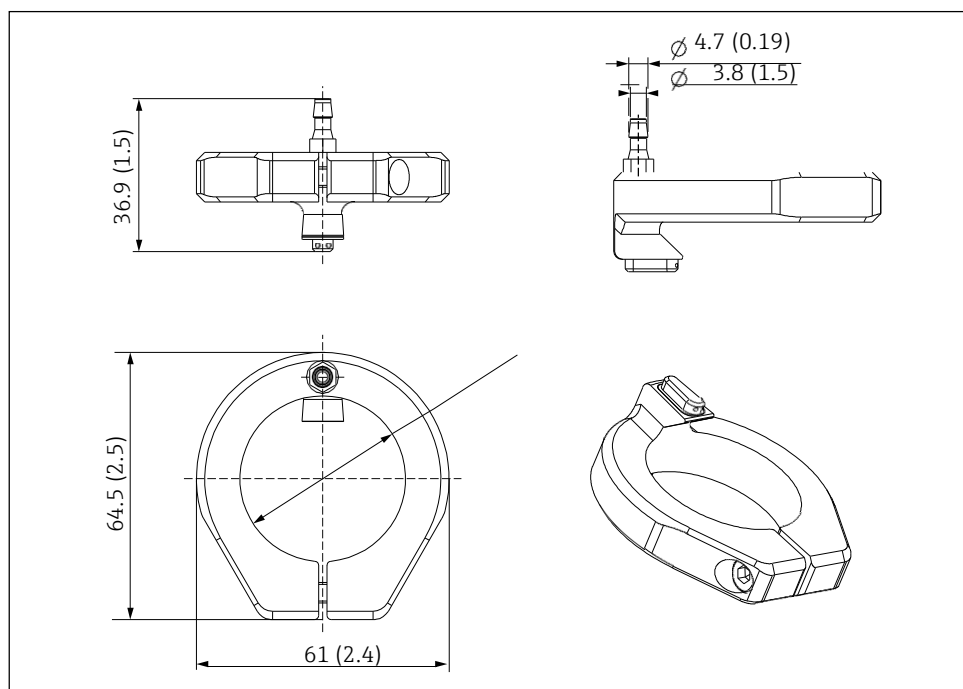

A0036826

20 Dimensions for compressed air cleaning. Dimensions: mm (in)

Compressed air cleaning: 2 bar (29 psi) maximum pressure

**Weight**

Cable length	Plastic sensor	Metal sensor	Metal sensor with clamp
3 m (9.84 ft)	0.46 kg (1.5 lbs)	1.15 kg (2.54 lbs)	1.21 kg (2.67 lbs)
7 m (23 ft)	0.68 kg (1.5 lbs)	1.37 kg (3.81 lbs)	1.43 kg (3.15 lbs)
15 m (49.2 ft)	1.15 kg (2.54 lbs)	1.83 kg (4.03 lbs)	1.9 Kg (4.19 lbs)

**Materials**

	Plastic sensor	Metal sensor
Sensor head:	PCTFE	PCTFE
Sensor housing:	PPS/GF40%	1.4571/AISI 316Ti
Sensor threaded connection:	PPS/GF40%	1.4404/AISI316L
O-rings:	EPDM	EPDM

The data refer to the wetted materials when the sensor is installed correctly in Endress+Hauser assemblies.

**Process connections**

- G1 and NPT<sup>3/4</sup>
- Clamp 2" (depending on sensor version)/DIN 32676





**Scope of delivery**

- The delivery comprises:
- 1 OCUS50D sensor, version as ordered
  - 1 Operating Instruction Manual

**Accessories**

The following are the most important accessories available at the time this documentation was issued.

- ▶ For accessories not listed here, please contact your Service or Sales Center.

**Assemblies**

**FlowFit CUA120**

- Flange adapter for mounting turbidity sensors

**Flowfit CUA252**

- Flow assembly

**Flowfit CUA262**

- Weld-in flow assembly

**Flexdip CYA112**

- Immersion assembly for water and wastewater
- Modular assembly system for sensors in open basins, channels and tanks
- Material: PVC or stainless steel

**Cleanfit CUA451**

- Manual retractable assembly made of stainless steel with ball valve shut-off for turbidity sensors

**Flowfit CYA251**

- Connection: See product structure
- Material: PVC-U

**Holder**

**Flexdip CYH112**

- Modular holder system for sensors and assemblies in open basins, channels and tanks
- For Flexdip CYA112 water and wastewater assemblies
- Can be affixed anywhere: on the ground, on the coping stone, on the wall or directly onto railings.
- Stainless steel version

**Mounting material**

**Weld-in adapter for clamp connection DN 50**

- Material: 1.4404 (AISI 316 L)
- Wall thickness 1,5 mm (0.06 in)
- Order number: 7124220

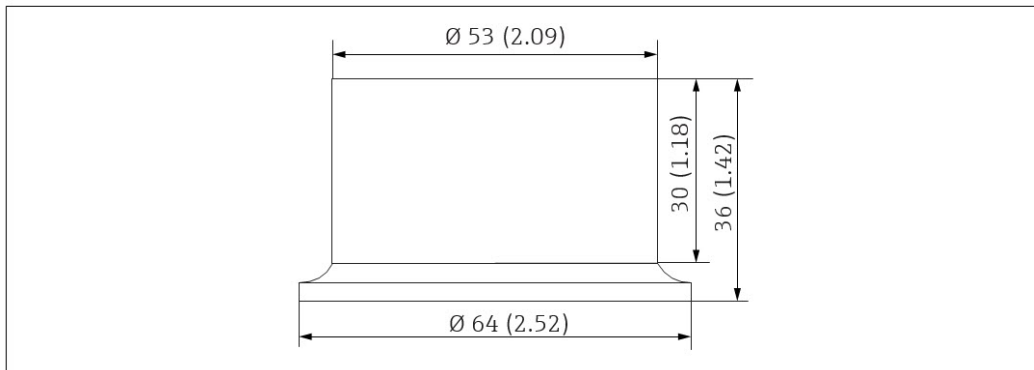

21 Weld-in adapter. Dimensions: mm (in)

**Mounting material****Weld-in adapter for clamp connection DN 50**

- Material: 1.4404 (AISI 316L)
- Wall thickness 1.5 mm (0.06 in)
- Order number: 71242201

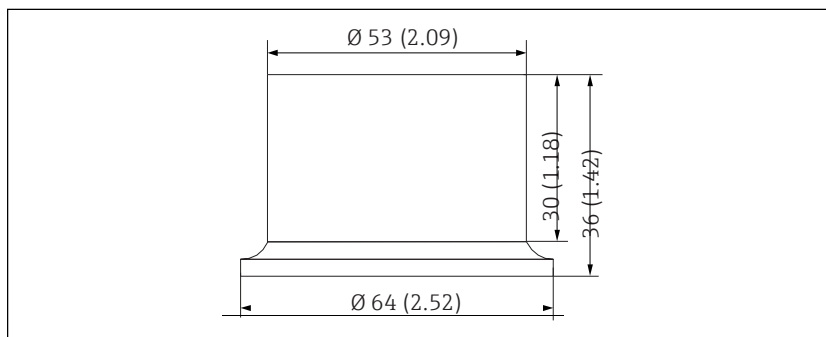

21 Weld-in adapter. Dimensions: mm (in)

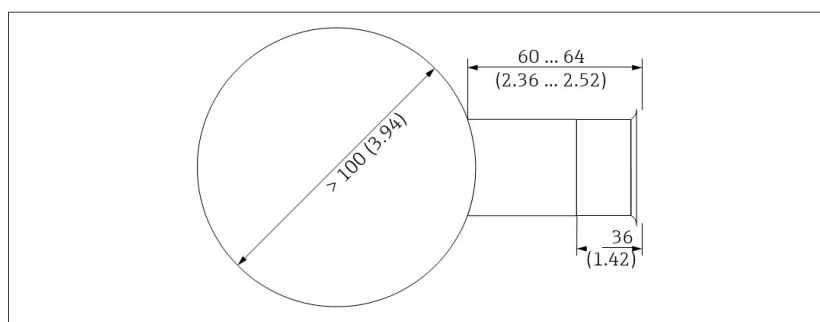

22 Pipe connection with weld-in adapter. Dimensions: mm (in)

**Compressed air cleaning****Compressed air cleaning for OCUS50D**

- Connection: 6 mm (0.24 in)
- Pressure: 1.5 to 2 bar (21.8 to 29 psi)
- Materials: POM, PE, PA 6.6 30% glass fiber
- Order number: 71395617

**Compressor**

- For compressed air cleaning
- 230 V AC, order number: 71072583
- 115 V AC, order number: 71194623

**Calibration kit****OCUS50D kit, solid state reference**

- Calibration tool for OCUS50D turbidity sensor
- Easy and reliable inspection of OCUS50D turbidity sensors
- Order number: 71400898